

A Comparative Analysis of UPQC for Power Quality Improvement

N.Vasanthakumar, A.Dhamendarsingh

Assistant Professor & Head, Dept. of EEE, RVS Padhmavathy college of Engineering & Technology, Tamilnadu, India

UG Student, Dept. of EEE, RVS Padhmavathy college of Engineering & Technology, Tamilnadu, India

ABSTRACT: in recent years, Power engineers are increasingly concerned over the quality of the electrical power. In modern power system consists of wide range of electrical, electronic and power electronic equipment in commercial and industrial applications. Since most of the electronic equipment's are nonlinear in nature these will induce harmonics in the system, which affect the sensitive loads to be fed from the system. One among the many compensating devices is Unified Power Quality Conditioner (UPQC) which specifically aims at the integration of series-active and shunt-active power filters to mitigate any type of voltage and current fluctuations and power factor correction in a power distribution network, such that improved power quality can be made available at the point of common coupling. In This paper presents a comprehensive review on the unified power quality conditioner (UPQC) to enhance the electric Power quality at distribution levels.

KEYWORDS :FACTS, SSSC,SVC, IPFC, CSC, UPFC, UPQC, STATCOM.

- *Static VAR Compensator (SVC) -Controls voltage*
- *Thyristor Controlled Series Compensator (TCSC)-Controls impedance*
- *Static Synchronous Series Controller (SSSC)*
- *Unified Power Flow Controller (UPFC)*
- *Unified Power Quality Conditioner (UPQC)*

I. INTRODUCTION

In the last two decades, power demand has increased substantially while the expansion of power generation and transmission has been severely limited due to limited resources and environmental restrictions. Power quality is very important term that embraces all aspects associated with amplitude, phase and frequency of the voltage and current waveform existing in a power circuit. Any problem manifested in voltage, current or frequency deviation that results in failure of the customer equipment is known as power quality problem.

Flexible AC transmission systems (FACTS) controllers have been mainly used for solving various power system steady state control problems. Flexible AC transmission systems or FACTS are devices which allow the flexible and dynamic control of power systems. The FACTS devices can be divided in three groups, dependent on their switching technology: mechanically switched (such as phase shifting transformers), Thyristor switched or fast switched, using IGBTs.

- 1) Static VAR Compensator (SVC) is a first generation FACTS device that can control voltage at the required bus thereby improving the voltage profile of the system.
- 2) Thyristor Controlled Series Capacitor (TCSC) is one of the important members of FACTS family that is increasingly applied with long transmission lines by the utilities in modern power Systems. It can have various roles in the operation and control of power systems, such as scheduling power flow; decreasing unsymmetrical components; reducing net loss; providing voltage support; limiting short-circuit currents; mitigating sub synchronous resonance (SSR); damping the power oscillation; and enhancing transient stability.
- 3) A Static Synchronous Series Compensator (SSSC) is a member of FACTS family which is connected in series with a power system. It consists of a solid state voltage source converter which generates a controllable alternating current

voltage at fundamental frequency.

II. DIFFERENT FACTS CONTROLLER

Static Var Compensator (SVC)

Static var systems are applied by utilities in transmission applications for several purposes. The primary purpose is usually for rapid control of voltage at weak points in a network. Installations may be at the midpoint of transmission interconnections or at the line ends. Static Var Compensators are shunting connected static generators / absorbers whose outputs are varied so as to control voltage of the electric power systems. In its simple form, SVC is connected as Fixed Capacitor-Thyristor Controlled Reactor (FC-TCR) configuration as shown in Fig. 1. The SVC is connected to a coupling transformer that is connected directly to the ac bus whose voltage is to be regulated. The effective reactance of the FC- TCR is varied by firing angle control of the anti parallel thyristors. The firing angle can be controlled through a PI (Proportional + Integral) controller in such a way that the voltage of the bus, where the SVC is connected, is maintained at the reference value.

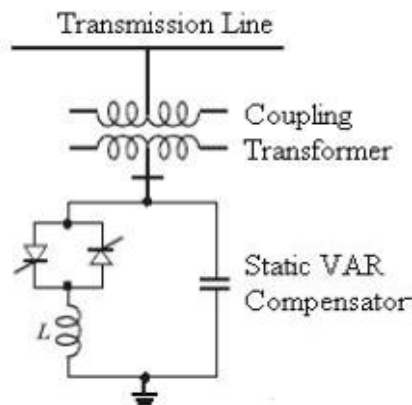

Fig No.1 Configuration of SVC

Thyristor Controlled Series Capacitor (TCSC)

TCSC is one of the most important and best known FACTS devices, which has been in use for many years to increase the power transfer as well as to enhance system stability. The main Circuit of a TCSC is shown in Fig. 2. The TCSC consists of three main components: capacitor bank C, bypass inductor L and bidirectional Thyristor SCR1 and SCR2. The firing angles of the Thyristor are controlled to adjust the TCSC reactance in accordance with a system control algorithm, normally in response to some system parameter variations. According to the variation of the Thyristor firing angle or conduction angle, this process can be modeled as a fast switch between corresponding reactance's offered to the power system.

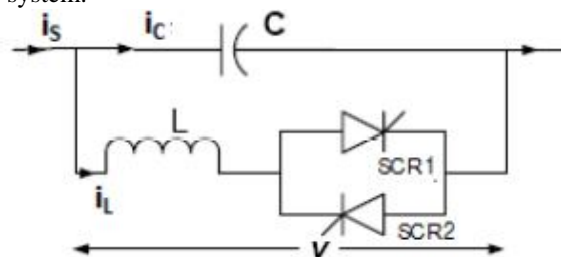

Fig. 2 Configuration of a TCSC

Static Synchronous Series Compensator (SSSC)

The SSSC is one of the most recent FACTS devices for power transmission series compensation. It can be considered as a synchronous voltage source as it can inject an almost sinusoidal voltage of variable and controllable

amplitude and phase angle, in series with a transmission line. The injected voltage is almost in quadrature with the line current. A small part of the injected voltage that is in phase with the line current provides the losses in the inverter. Most of the injected voltage, which is in quadrature with the line current, provides the effect of inserting an inductive or capacitive reactance in series with the transmission line. The variable reactance influences the electric power flow in the transmission line. The basic configuration of a SSSC is shown in Fig. 3.

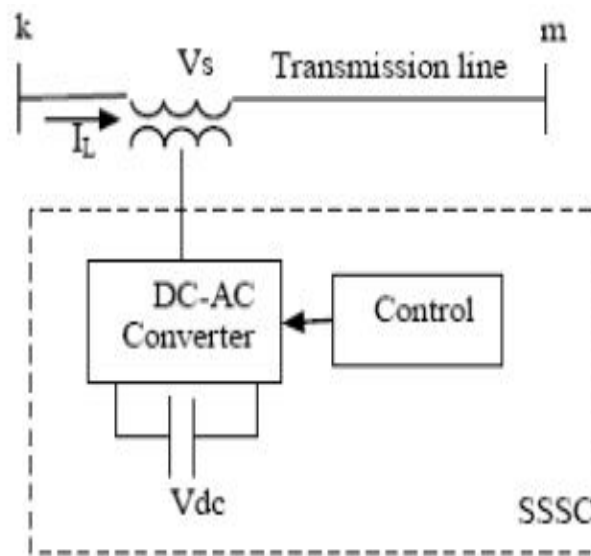

Fig. 3 Simplified diagram of a SSSC

Unified Power Flow Controller (UPFC)

The basic configuration of a UPFC is shown in Fig. 4. The UPFC is capable of both supplying and absorbing real and reactive power and it consists of two ac/dc converters. One of the two converters is connected in series with the transmission line through a series transformer and the other in parallel with the line through a shunt transformer. The dc side of the two Converters are connected through a common capacitor, which provides dc voltage for the converter operation. The power balance between the series and shunt converters is a pre requisite to maintain a constant voltage across the dc capacitor. As the series branch of the UPFC injects a voltage of variable magnitude and phase angle, it can exchange real power with the transmission line and thus improves the power flow capability of the line as well as its transient stability limit. The shunt converter exchanges a current of controllable magnitude and power factor angle with the power system. It is normally controlled to balance the real power absorbed from or injected into the power system by the series converter plus the losses by regulating the dc bus voltage at a desired value.

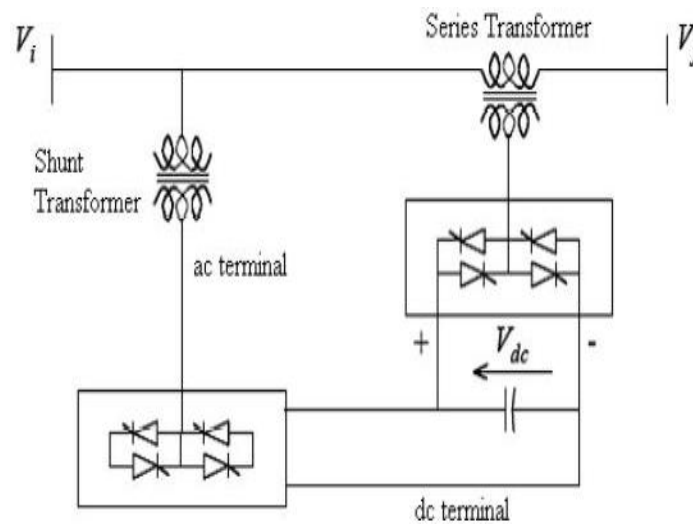

Fig. 4 Configuration of UPFC

Unified Power Quality Conditioner(UPQC):

Among the available FACTS devices, the Unified Power Flow Controller (UPFC) is the most versatile one that can be used to enhance steady state stability, dynamic stability and transient stability. A multi-level converter is proposed to increase the converter operation voltage, avoiding the series connection of switching elements. However, the multilevel converter is complex to form the multi converter. UPQC consists of two VSC's. The two voltage source converters are connected with a commutation reactor and high pass output filter to prevent the flow of switching harmonics in to the supply. The voltage source converters are controlled by pulse width modulation (PWM) techniques.

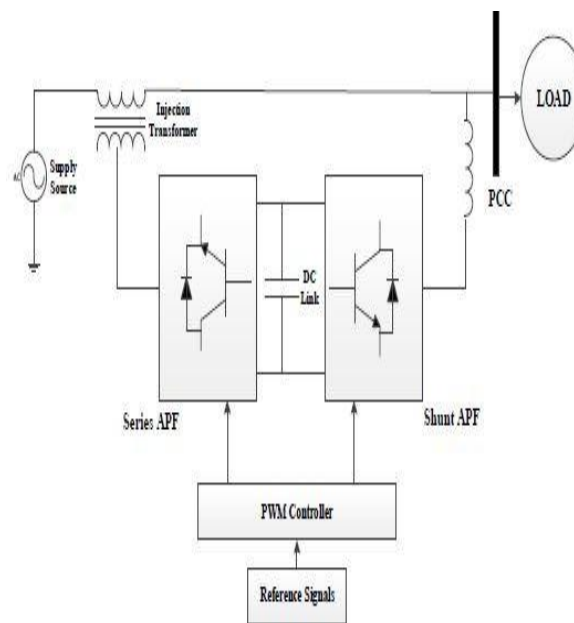

Fig. 5: UPQC with controller arrangement

III. COMPARITIVE POINTS

Settling time:

The comparison between different facts controller on the basis of their settling time in post fault period is shown in following table.

Two-area Power System With	Power System Stability Enhancement	Settling time in post fault period (in seconds)
UPQC	YES	0.08
UPFC	YES	0.6
TCSC	YES	1.5
SVC	YES	7
SSSC	YES	11

Load Flow:

Facts devices	Load Flow
UPQC	High
UPFC	High
SSSC	Medium
TCSC	Low
SVC	Low

Voltage control:

Facts devices	Voltage control
UPQC	High
UPFC	High
SSSC	Low
TCSC	High
SVC	High

Transient stability:

Facts devices	Transient stability
UPQC	High
UPFC	Medium
SSSC	High
TCSC	Low
SVC	Medium

Device used:

Facts devices	Device used
UPQC	Series and shunt APFs with DC capacitor
UPFC	Combination of sssc and statcom
SSSC	Voltage source converter
TCSC	capacitor bank , bypass inductor and bidirectional thyristors
SVC	Fixed Capacitor-Thyristor

Parameter controlled:

Facts devices	Parameter
UPQC	Series Active and Reactive power
UPFC	Real time control and dynamic compensation
SSSC	Exchange active and reactive power with transmission system
TCSC	Series active power
SVC	Series reactive power

Effective Location:

Facts devices	Location
UPQC	At the point of common coupling
UPFC	At the point of installation
SSSC	At midpoint of transmission line
TCSC	At the end of transmission line where reactive power or voltage support is necessary
SVC	at the midpoint of transmission interconnections or at the line ends

IV. CONCLUSION

The power quality problems in distribution systems are not new but customer awareness of these problems increased recently. It is very difficult to maintain electric power quality at acceptable limits. One modern and very promising solution that deals with both load current and supply voltage imperfections is the Unified Power Quality Conditioner (UPQC). This paper presented review on the UPQC to enhance the electric power quality at distribution level. The UPQC is able to compensate supply voltage power quality issues such as, sags, swells, unbalance, flicker, harmonics, and for load current power quality problems such as, harmonics, unbalance, reactive current and neutral current. In this paper several facts device configurations have been discussed. Among all these configurations, UPQC could be the most interesting solution for power quality improvement.

REFERENCES

- [1] D. Murali, oct 2010, "Comparision of FACTS devices for power system stability Enhancement" IJCA, in vol 8-no 4.
- [2] Ranjtkumar Bindal, Apr 2014, "A review of Benefits of FACTS devices in power system" IJEAT ISSN:2249-8958, vol-3, Issue-4
- [3] VJSAireshkumar G Mathad, march 2013, "Review on comparision of FACTS controllers for power system stability enhancement" IJSARP, vol 3, Issue3.
- [4] Mr. Suhas M Shembekar, "Conditioning of Power Quality in transmission network using UPQC" IJRAT page no.43- 50, vol.3, no.1, jan2015.
- [5] Mr. Shaktisinh N. Gohil, "A comparative analysis of UPQC for Power Quality Improvement" JIKREE, Nov12 to Oct13, vol 2, issue 2.
- [6] B Jyoti, "Analysis Of Unified Power Quality Conditioner During Voltage and Swell conditions" page no.85-91, vol 2, issue1, jan-feb 2012
- [7] Tan Zhili "A New control strategy of UPQC in Three Phase Four wire system" IEEE Transaction 2007.
- [8] H. Akagi, Edson Hirokazu Wantanbe and Mauricio Aredes, "Instantaneous Power Theory and Applications to Power Conditionong" IEEE Press 2007.
- [9] A. Ghosh, G. Ledwich "Power Quality Enhancement Using Custom Power Devices" Kluwer Academic Publisher, 2002. ISBN 1-4020 7180-9.
- [10] H. Fujita and H. Akagi, "The unified power quality conditioner: The integration of series And shunt active filters," *IEEE Trans. Power Electron.*, vol. 13, no. 2, pp. 315-322, Mar.1998.
- [11]