

International Journal of Innovative Research in Science, Engineering and Technology

(An ISO 3297: 2007 Certified Organization)

Vol. 5, Issue 4, April 2016

Simulink Based Three Phase Power Control Driver for BLDC Motor with Sensorless Rotor Positioning System

Rashmi Soni¹ Seema Sahu²

M.Tech Student, Department of Electrical and Electronics Engineering, Disha Institute of Management and Technology, Raipur, Chhattisgarh, India.¹

M.Tech Student, Department of Electrical and Electronics Engineering, Disha Institute of Management and Technology, Raipur, Chhattisgarh, India.²

ABSTRACT: This paper presents a simulation for three Phase Power Control Driver for BLDC Motor with Sensorless Rotor Positioning System using MATLAB. This describes the procedure of deriving an easy model for the brush less dc motor with 3-phase inverter system, speed regulator and current controller.

In this paper sensing of rotor position is done by using comparison and calculation method. Here the actual speed of BLDC motor is compared with the reference speed and the error signal thus produces, regulates the speed controller. This speed controller produces reference torque which is used to calculate reference current. Hysteresis current controller regulates current within reference current. It provides the pwm gating signals to inverter. Now here inverter is used to drive BLDC motor accordingly. This BLDC motor is in a wide use today in various industries so it is very important to improve its efficiency. So here represent a paper which shows the improvement in BLDC motor and reduces the manufacturing cost of drive.

The most advantageous part of this project is that it determines the rotor position with simple calculations and comparisons and does not use any sensor. The effectiveness of this method is validated by simulation results in MATLAB simulink platform.

KEYWORDS: BLDC motor, sensorless rotor position, PI controller, 3 phase inverter, hysteresis current controller.

I.INTRODUCTION

Brushless dc motors have only decades of history. They have been gaining attention from various industrial and household appliance manufacturers because of its high efficiency, high power density and low maintenance cost, silent operation, compact form and reliability. Having various applications in industries like compressor, electric vehicles, hard disc drives and robotic arms etc. The rotor position is sensed with an optical encoder or a resolver for high-performance applications. The position sensors cost as much as a low-power motor, thus making the total system cost very noncompetitive compared to other types of motor drives.

The most advantageous part of this project is that it does not use any rotor positioning sensors. Back emf method for sensorless rotor position estimation has some disadvantage that at standstill or at low speeds, it is impossible or very difficult to estimate the position of the rotor. It is necessary to obtain a stable starting and acceleration up to the nominal operation speed under severe mechanical disturbances. In BLDC's applications, estimation of the initial rotor position is important not only for stable starting but also for maximum starting torque to reduce the startup time. In another method to measure the stator inductance that varies with rotor position, a number of voltage pulses are applied periodically to the motor. Since the applied voltage pulses make the system inefficient, these methods are not adequate. In a conventional method, a predetermined voltage has been applied that rotates the rotor synchronously with the applied voltage from standstill. In that method, the motor parameters, such as the torque constant, friction coefficient and inertia of the rotor, should be known for a stable start of the motor. However, a sudden change of the load may

International Journal of Innovative Research in Science, Engineering and Technology

(An ISO 3297: 2007 Certified Organization)

Vol. 5, Issue 4, April 2016

cause motor start failure. Therefore there is needed some improved method for BLDC motor rotor position sensing. Here the rotor position sensing is done by simple calculations done by controllers.

II. RELATED WORK

Here fig.1 shows the block diagram for the bldc motor drive system which we are using in this project. Here this block diagram shows the closed loop control system for the BLDC drive. The working of this drive can be explained as follows:

1. The BLDC motor is fed by a three phase MOSFET based inverter.
2. The PWM gating signals for firing the MOSFETS in the inverter is injected from a hysteresis current controller. It is also required to maintain the current constant within the 60 degree interval of one electrical revolution of the rotor. It regulates the actual current within the hysteresis band around the reference currents.
3. The reference currents are generated by a reference current generator depending upon the steady state operating mode. The reference currents are of quasi –square wave. They are developed in phase with the back-emf in motoring mode and out of phase in braking mode.
4. The magnitude of this reference current is calculated from the reference torque.
5. The reference torque is obtained by limiting the output of PI controller.
6. The PI controller processes on the speed error signal i.e. the difference between the reference speed and actual speed and gives output to the limiter to produce the reference torque. The actual speed is sensed back to the speed controller and processed on to minimize the error in tracing the reference speed.
7. The whole block is then simulated in MATLAB and get the expected results and fig.3 here shows the simulated model of power control driver of BLDC motor.

II. SYSTEM DESCRIPTION

The complete drive system can be categorized into BLDC motor, Inverter, Current Controller, Speed Controller, reference current generator. Each block is modeled separately and integrated together. Here PI controller forms outer closed loop and current controller forms the inner closed loop. This block diagram shows the complete BLDC motor drive system.

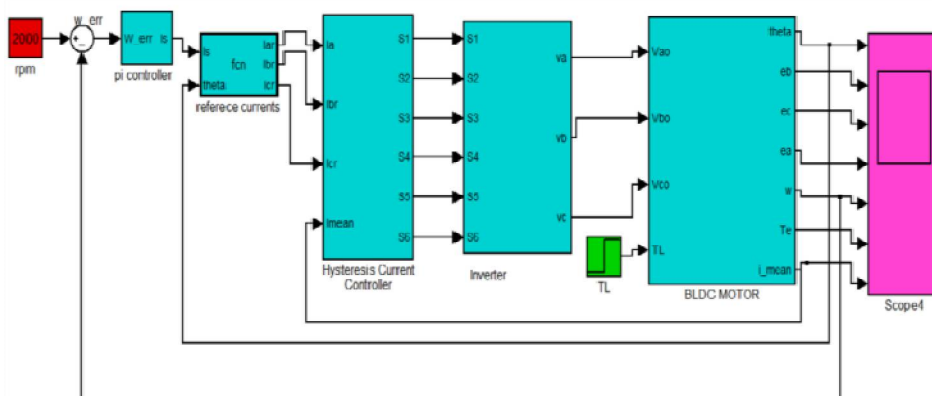

Fig.1. BLDC motor drive system

International Journal of Innovative Research in Science, Engineering and Technology

(An ISO 3297: 2007 Certified Organization)

Vol. 5, Issue 4, April 2016

Modeling of the BLDC motor Drive system:

BLDC motor can be realized mathematically in two ways:- abc phase variable model and d-q axis model. In a BLDC motor, the trapezoidal form of back EMF implies that, the mutual inductance between stator and rotor is non sinusoidal, thus transforming to d-q axis does not provide any advantage, and so abc phase variable model is preferred here. Following assumptions are taken here:

- The motor is not saturated.
- Stator resistances of all the windings are equal and self and mutual inductances are constant.
- Power semiconductor devices in the inverter are ideal.

Under the above assumptions, The electrical and mechanical system is realized as:

$$\frac{di_a}{dt} = - \left(\frac{di_b}{dt} + \frac{di_c}{dt} \right) \quad (1)$$

$$\frac{di_b}{dt} = \frac{1}{3L_t} [V_{ca} + 2V_{bc} - 3Ri_b + (e_a + e_c - 2e_b)] \quad (2)$$

$$\frac{di_c}{dt} = \frac{1}{3L_t} [V_{ca} - V_{bc} - 3Ri_c + (e_a + e_b - 2e_c)] \quad (3)$$

$$E_k = \sum_k K_e W_n f_k(\theta_r) \quad (4)$$

And the electromagnetic torque can be express as

$$T_l - T_e = J \frac{dW_m}{dx} + BW_m \quad (5)$$

And electrical rotor speed and position are related by

$$\frac{d\theta}{dt} = \frac{P}{2} \times W_m \quad (6)$$

Where K=a,b,c and K_e is torque constant.

Equation is obtained by solving the loop equation when an inverter is connected to a star load.

$$\begin{bmatrix} V_{an} \\ V_{bn} \\ V_{cn} \end{bmatrix} = R_s \begin{bmatrix} I_a \\ I_b \\ I_c \end{bmatrix} + (L_s + m) \begin{bmatrix} \frac{di_a}{dt} \\ \frac{di_b}{dt} \\ \frac{di_c}{dt} \end{bmatrix} + \begin{bmatrix} e_{an} \\ e_{bn} \\ e_{cn} \end{bmatrix} \quad (7)$$

Inverter Modeling

The inverter supplies the input voltage for the three phases of the BLDC motor. It comprises of two power semiconductor devices on each phase leg.

International Journal of Innovative Research in Science, Engineering and Technology

(An ISO 3297: 2007 Certified Organization)

Vol. 5, Issue 4, April 2016

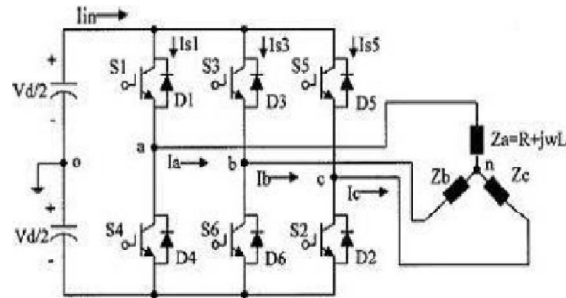

Fig2. Three phase inverter model

$$V_{an} = (S_1) \times \left(\frac{V_d}{2}\right) - (S_4) \times \left(\frac{V_d}{2}\right) - V_f \quad (8)$$

$$V_{bn} = (S_3) \times \left(\frac{V_d}{2}\right) - (S_6) \times \left(\frac{V_d}{2}\right) - V_f \quad (9)$$

$$V_{cn} = (S_5) \times \left(\frac{V_d}{2}\right) - (S_2) \times \left(\frac{V_d}{2}\right) - V_f \quad (10)$$

Where, V_{an} , V_{bn} and V_{cn} are line-neutral voltages, v_d is the DC-link voltage, v_f is the forward diode voltage drop. As sensors are the direct feedback of the rotor position, synchronization between stator and rotor flux is achieved.

Modeling Of Hysteresis Current Controller

Hysteresis controller limits the phase currents within the hysteresis band by switching ON/OFF the power devices. The switching pattern is given as:

If $i_a^{err} > UL$, S1 is on and S4 is off.

If $i_a^{err} < LL$, S1 is off and S4 is on.

If $i_b^{err} > UL$, S3 is on and S6 is off.

If $i_b^{err} < LL$, S3 is off and S6 is on.

If $i_c^{err} > UL$, S5 is on and S2 is off.

If $i_c^{err} < LL$, S5 is off and S2 is on.

Where

$$i_k^{err} = i_k^{ref} - i_k^{mean} \quad (11)$$

UL, LL are the upper and lower limits of hysteresis band. Thus, by regulating the current desired quasi-square waveforms can be obtained.

International Journal of Innovative Research in Science, Engineering and Technology

(An ISO 3297: 2007 Certified Organization)

Vol. 5, Issue 4, April 2016

Modeling Of Reference Current Generator

The magnitude of the reference current (I_s) is determined by using reference torque (T^*) and the back emf constant (K_b). Depending on the rotor position, the K_b reference current generator block generates three- phase reference currents (I_{ar} , I_{br} , I_{cr}) considering the value of reference current magnitude as I_s , $-I_s$ and zero. The reference current generation is explained in the Table

Table: Rotor position signal Vs reference current

Θ	I_{ar}	I_{br}	I_{cr}
0-60	0	I_s	$-I_s$
60-120	I_s	0	$-I_s$
120-180	I_s	$-I_s$	0
180-240	0	$-I_s$	I_s
240-300	$-I_s$	0	I_s
300-360	$-I_s$	I_s	0

Modelling of Speed Controller

Conventional PI controller is used as a speed controller for recovering the actual motor speed to the reference speed. The reference and the measured speed are the input signals to the PI controller. The K_P and K_I values of the controller are determined by trial and error method for set speed. The controller output is limited to give the reference torque.

III. METHODOLOGY

The block diagram of fig.1 is the simulated in MATLAB. The various Simulink components are used and connected in a circuit so thus it forms a closed loop power control driver for BLDC motor. Also there scope gives the expected output as shown in the result.

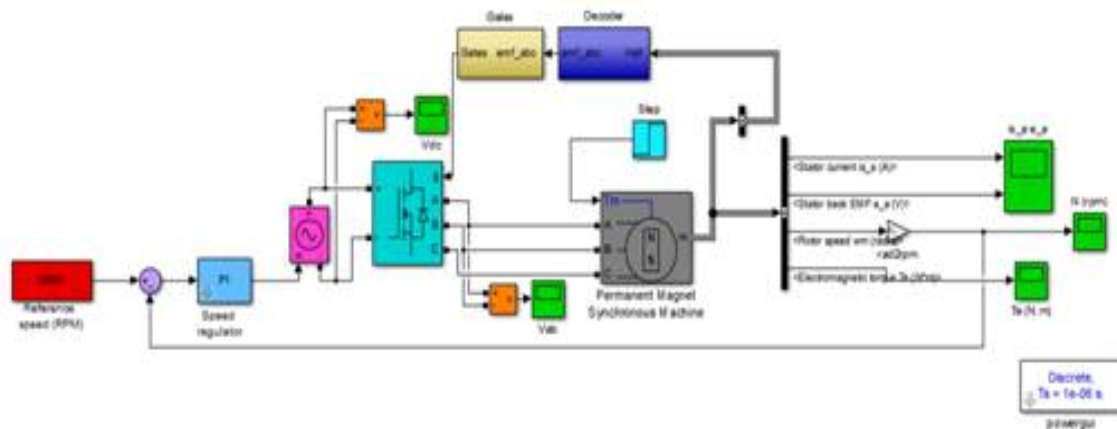

Fig3. Simulink model of Power Control Driver of BLDC Motor

International Journal of Innovative Research in Science, Engineering and Technology

(An ISO 3297: 2007 Certified Organization)

Vol. 5, Issue 4, April 2016

IV. SIMULINK RESULTS

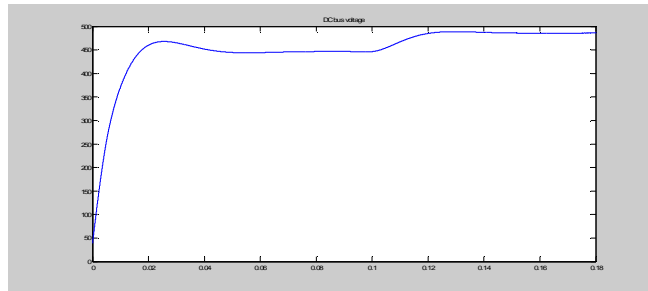

Fig4. Graph shows DC BUS VOLTAGE vs TIME

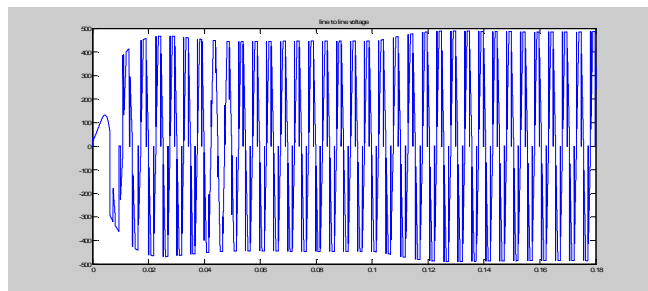

Fig5. Graph shows V_{ab} vs TIME

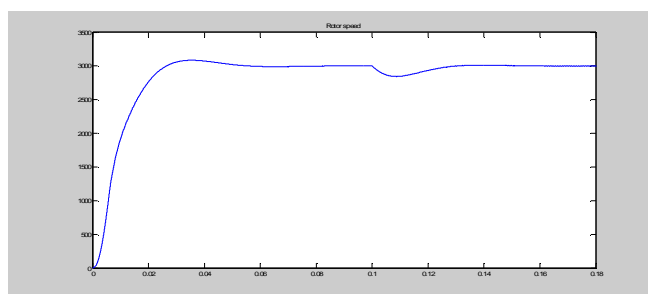

Fig6. Graph shows SPEED vs TIME

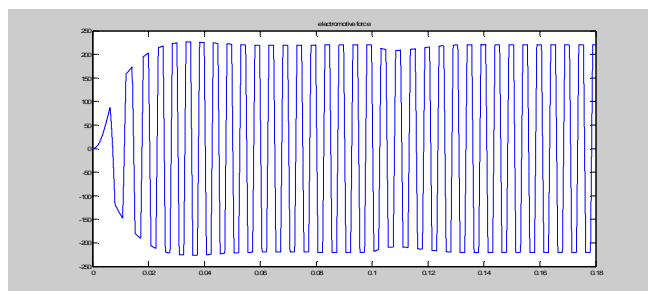

Fig6. Graph shows ELECTROMOTIVE FORCE vs TIME

International Journal of Innovative Research in Science, Engineering and Technology

(An ISO 3297: 2007 Certified Organization)

Vol. 5, Issue 4, April 2016

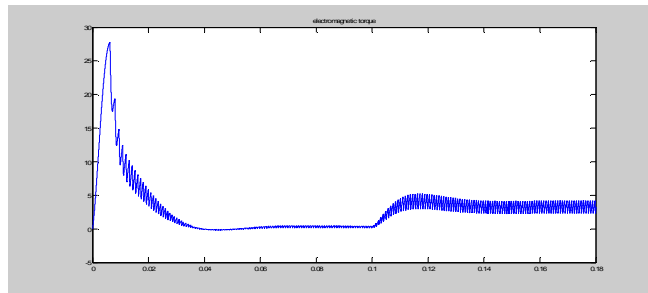

Fig7. Graph shows ELETROMAGNETIC TORQUE vs TIME

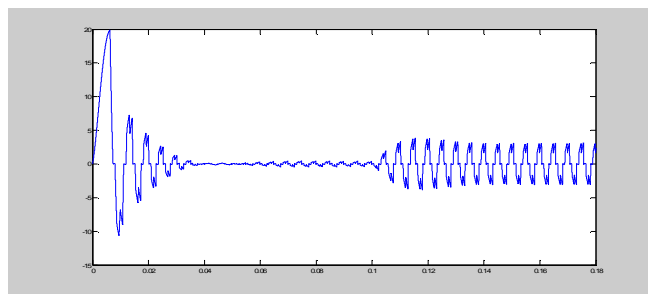

Fig8. Graph shows STATOR CURRENT vs TIME

The simulation results demonstrate that by using the proposed sensorless method, the quadrature stator current (i_{sq}) will be increased that, in turn, increases the starting torque by about 14% and 5% compared with the 60 degree and 30 degree resolution methods, respectively. The ripple of the quadrature stator current (i_{sq}) is reduced significantly. Also as shown in graph, the starting torque ripple is decreased, while the average starting torque is increased significantly. It is demonstrated that the startup is much faster (about 25%) in the proposed method. Graph shows the Simulink model of the sensorless drive of the motor.

V. CONCLUSION

Here the non-linear simulation model of the BLDC motor drive system with PI control based on Simulink platform is presented. In this model control structure has two loops. An inner current closed-loop and outer speed loop to govern the current. The speed controller regulates the rotor movement by varying the frequency of the pulse. The behavior and performance of BLDC motor drive are shown in above SIMULINK. Results show that, such a modeling is very useful in studying the drive system. The application of this work is on the basis of simulation and analysis carried out can be to select the proper motor specifications to match the load requirements. The simulation is used to predict the behavior of actual system. These predicted results can be used to determine the range of parameters of controller while designing the system.

REFERENCES

- [1] Kai-Sheng Kan, "A Sensorless Iff Control Method for Single-Phase BLDC Fan Motors with Efficiency Optimization by Power Factor Control" 2012 IEEE.
- [2] Sunit Kumar Saxena Tarak Saha, "Ultra High Speed Operation of BLDC Motor with Enhanced Motor Dynamics for Space Limited Applications" 2012 IEEE.
- [3] Kai Sheng Kan "Adaptive Wide Angle PWM Control Strategy of BLDC Motor Drive for Efficiency Optimization and Wide Speed Control Range" 2011 IEEE.
- [4] Taeyeon Kim, Chungil Kim, Joon Lyoo "A New Sensorless Drive Scheme for a BLDC Motor Based on the Terminal Voltage Difference" 2011 IEEE.
- [5] Vinatha u. shwetha pola "simulation of four quadrant operation & speed control of BLDC motor on MATLAB" 2008 IEEE.