

Design and Development of Landmine Detecting Robot

K.S. Ruchitha¹, Soumya Anand², Anurima Das³, Rajasree P.M⁴

U.G. Student, Department of Electronics and Instrumentation Engineering, R.V College of Engineering, Mysore Road,
Bangalore, India^{1,2,3}.

Assistant Professor, Department of Electronics and Instrumentation Engineering, R.V College of Engineering, Mysore
Road, Bangalore, India⁴

ABSTRACT: In this paper, we present the use of a low-cost robot for the detection of anti-personnel metal landmines using GSM technology. Nowadays, landmines in India are lethal artifacts mostly abandoned in rural areas and along the borders. According to Land-mine and Cluster Munition Monitor report in 2014, there are more than 110 million active mines scattered in 68 countries. Based on this fact, we propose DTMF communication module as a complementary tool for landmine detection. For this purpose, we have developed a robot whose movement and directions can be controlled remotely using GSM modem. A metal detector circuit with buzzer is implemented and AT89C51 microcontroller is used to regulate the complete operation.

KEYWORDS: AT89C51 (ATMEL 8051 microcontroller), DTMF (Dual Tone Multi Frequency), GSM (Global System for Mobile communication), landmine detection, robot.

I. INTRODUCTION

Landmines are weapons or explosives which are buried under the soil that are activated by pressure, and may kill or cause harm when stepped upon it, and also cause long term physiological effects. Landmines pose a serious threat to soldiers and civilians worldwide and also provide major challenges to agriculture, infrastructure and road development in post-conflict regions. The landmines are usually buried 10mm to 40mm below the soil and requires about minimum pressure of 9Kg to detonate them. The face diameter of these AP mines ranges from 5.6 to 13.3cm. Landmines are broadly categorized into two types of landmines Anti-Personnel and Anti-Tank landmines. Anti-personnel landmines are used to injure a person since it contains fewer amounts of explosives which get activated when pressure is applied on it while Anti-Tank landmines consists of large amount of explosives which can even destroy large tanks.

In order to demine the affected areas, several techniques have been developed to detect these threats. Since electromagnetic induction (EMI) based sensors can detect metal mines at a low cost, this method has been explored, and uses the electromagnetic characteristics of the mines or the mine casing. Several techniques such as GPR, infrared imaging, acoustic methods, etc. have already been explored which have proven to be less efficient and more expensive.

The present systems use wireless-controlled Robots that operate with the help of RF and IR technology, which have limited working range, frequency range and control. The use of electromagnetic sensor in the existing systems is extended to incorporate GSM technology, which overcomes the limitation of restricted frequency and working range as the GSM provided a worldwide range with no interference with other controller. This project aims at designing a landmine detecting robot that uses GSM technology and is controlled by the 89C51 microcontroller. With the help of mobile keys, we can move the robot in desired direction as per our requirement.

International Journal of Innovative Research in Science, Engineering and Technology

(An ISO 3297: 2007 Certified Organization)

Vol. 5, Issue 4, April 2016

II. RELATED WORK

The use of ground penetrating radar is to detect non-metal or low metal content landmines. Ground-penetrating radar (GPR) uses pulses to get the image of the surface beneath. The reflected signals are received by an antenna which tabulates the changes in the returning signal. This is done using high-frequency radio waves which hits different objects having different dielectric constants. The drawback is that the moisture content in the soil inhibits the effectiveness of GPR [1].

The next paper uses alpha particle imaging, ground penetrating radar, metal detector and infrared imaging for the confirmation of the explosive. The disadvantage of this method is that weak signals from nitrogen present in the soil interfere with the detection of the landmine [2].

In this paper, a holonomic mobile robot is presented which can work on any surface and thus, replaces the human involvement in demining operations. The flexible design of the robot enables it to move in any direction at any moment without changing the position of the body. Though this method replaces the human involvement in the demining operations, it is very slow process since the robot decides the path by itself and is also very expensive [3].

Another method of landmine detection is using an UAV which operates at some height and forms the image of the object using radar technology. This is an affordable method that can be easily used by everyone. It offers many advantages as it does not depend on the type of terrain but also has the disadvantage of limiting further advancement due to complex computing algorithms [4].

III. SYSTEM OVERVIEW

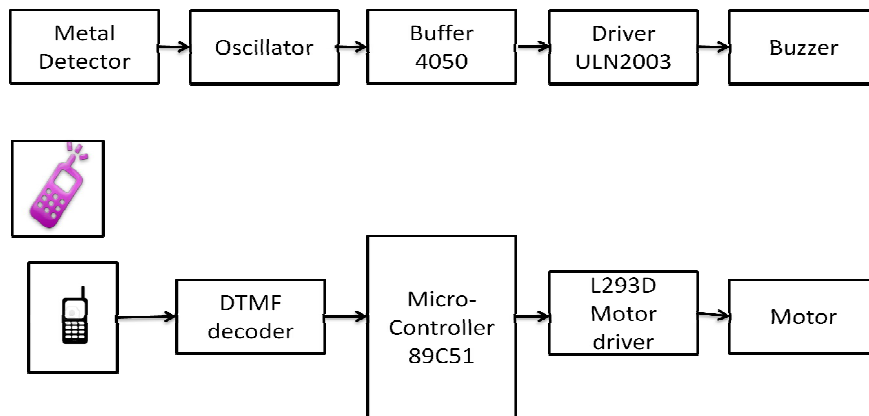

Fig1. Block diagram of metal detecting robot

Figure 1 represents the block diagram of metal detecting robot. The prototype presented here is an advanced Robotic System which can be controlled via GSM Network & GSM Mobile equipment. As shown in the Block Diagram, the project consists of a set of GSM equipment via; GSM Mobile Handset & GSM Mobile Infrastructure. Though a mobile handset one can dial the assigned number for that particular Robotic Vehicle & after the reception of acknowledgement signal, one can send the Control Signals in the form of DTMF codes via handset. Here each DTMF tone resembles a specific activity of the Robotic Vehicle and accordingly the Robotic Vehicle generates the actions. These actions can be either movement of the Robotic Vehicle. If metal is detected then automatically it starts buzzing which indicates the presence of a landmine or the metal is detected.

International Journal of Innovative Research in Science, Engineering and Technology

(An ISO 3297: 2007 Certified Organization)

Vol. 5, Issue 4, April 2016

The hardware components used for designing the robot are described below:

A. Power supply unit:

This section provides voltage of +5 V as working voltage. Figure 2 consists of a step down transformer of ratio 2:1 which is required to lower the ac voltage from the supply. The second stage is rectification for converting ac signal to pulsating dc signal. The third stage is filtering of the pulsating dc into pure dc and removal of the noise. The fourth stage is voltage regulation for obtaining 5V dc signal that can be used by the motor driver section.

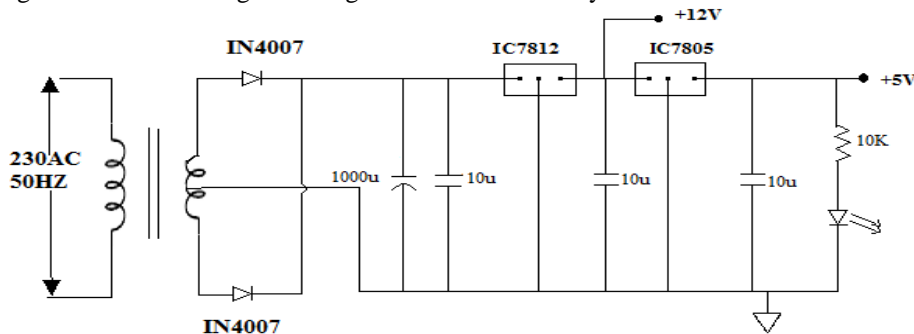

Fig2. Circuit diagram of power supply unit

B. Buffers:

Buffer is a storage device which stores the input analog signals. Buffers acts as a sample and hold circuit with resistors connected at the input section. The output of the buffer IC is used to drive the driver circuit which activates a relay.

C. L293D motor driver IC

Figure 3 shows L293D, a quadruple high- current half-H driver. The L293D provides bidirectional driving currents of maximum value 600-mA at voltages in the range of 4.5 V to 36 V. It can be used to drive the motor of the robot at some constant speed.

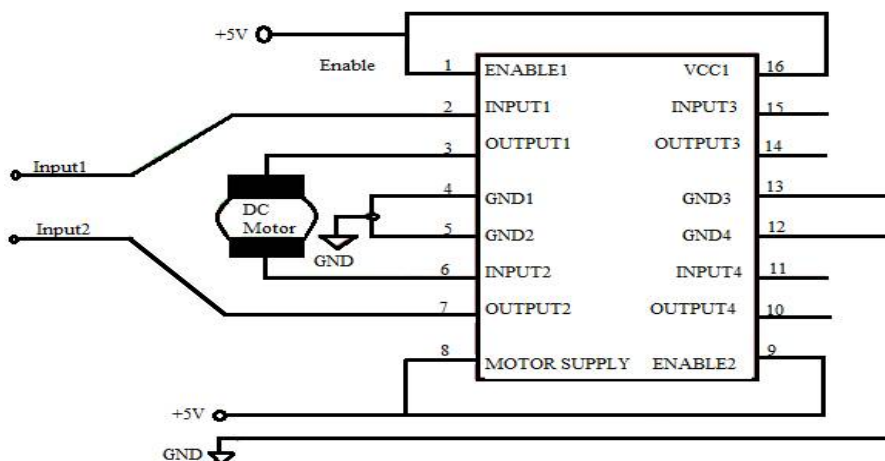

Fig3. Circuit Connection For Motor Driver L293D

D. Microcontroller 89C51

The 89C51 Micro-controller is the main component in the prototype. It is the chip that processes the User Data and executes the data. The code loaded in the chip manipulates the information and sends the result for visual display.

International Journal of Innovative Research in Science, Engineering and Technology

(An ISO 3297: 2007 Certified Organization)

Vol. 5, Issue 4, April 2016

E. Relays:

Relay is a device which uses electromagnetic principle to switch between two different voltages. It is used to operate the buzzer which is a high current device and also acts as an indicator.

F. Indicator:

Indicator provides visual indication of the relay which is activated or deactivated in the presence of any landmine, by glowing respective LED.

G. DTMF Decoder:

The DTMF signals consists of dual frequencies i.e., high and low group frequencies. These frequencies intersect to form different nodes which represent different keys in a DTMF device. The DTMF decoder decodes the incoming frequencies and converts it to binary signals. The CM8870 is a decoder IC that sends the binary code to the microcontroller. The corresponding action starts, according to the program loaded into the microcontroller. In figure 4, the IC1 denotes the CM8870 decoder.

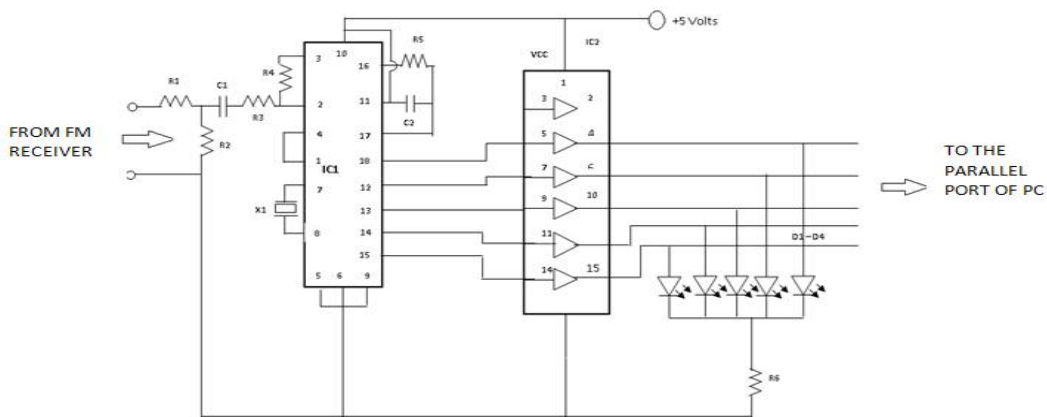

Fig4. Circuit Diagram of DTMF Decoder

H. Metal Detecting Circuit

The metal detecting circuit consists of three phases namely oscillation, amplification and switching. An induction coil along with two capacitors acts a Colpitt oscillator and is used for metal detection. In the presence of metal, the current in the coil changes due to eddy currents. Since, buzzer is a high current device; the signal needs to be amplified for its operation. This is done by using two stages of amplifier circuit consisting of one transistor each. The sensitivity of the transistors is set using a variable pot. Two diodes are connected in reverse to protect the circuit from any back e.m.f produced by the coil. The last stage of switching controls the on/off status of the buzzer. If the metal is detected, the current supply in the coil is disrupted.

International Journal of Innovative Research in Science, Engineering and Technology

(An ISO 3297: 2007 Certified Organization)

Vol. 5, Issue 4, April 2016

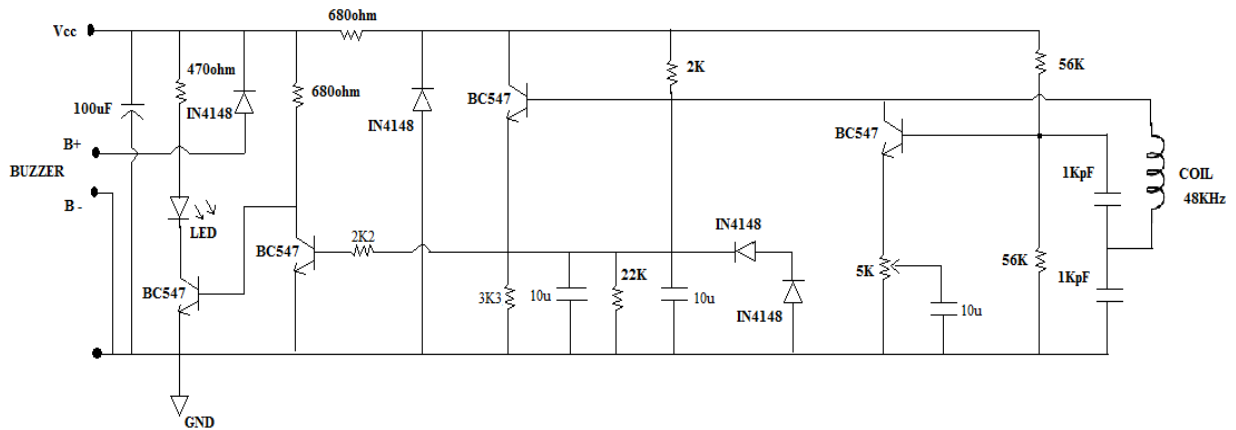
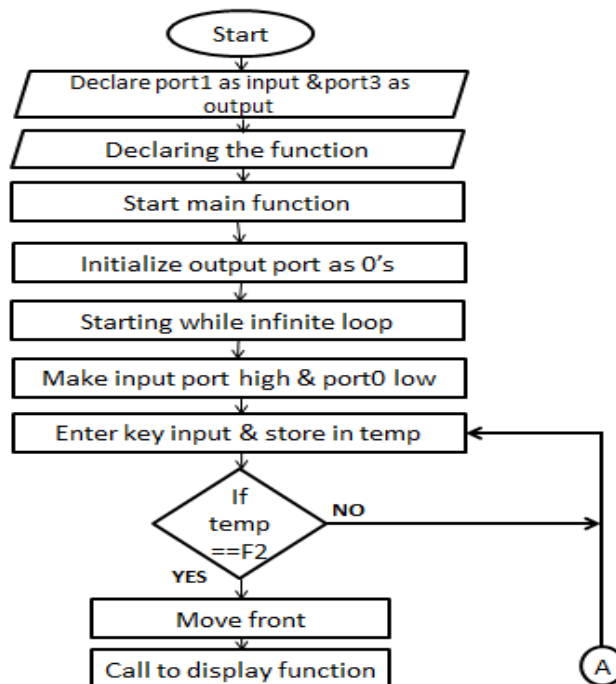

Fig5. Circuit Diagram of Metal Detector

The circuit shown in figure 5 is fabricated to detect the presence of a metal or landmine. When the metal is detected, it is indicated by the glowing of the LED and buzzer.

IV. SOFTWARE IMPLEMENTATION

The software implementation includes the coding of the microcontroller according to which the motor driver moves the motor and helps the robot to move in all four directions. The programming is done in C-language and code is dumped into the microcontroller using keil-µvision. Algorithm used is shown in figure 6 in the form of flowchart as given below:



International Journal of Innovative Research in Science, Engineering and Technology

(An ISO 3297: 2007 Certified Organization)

Vol. 5, Issue 4, April 2016

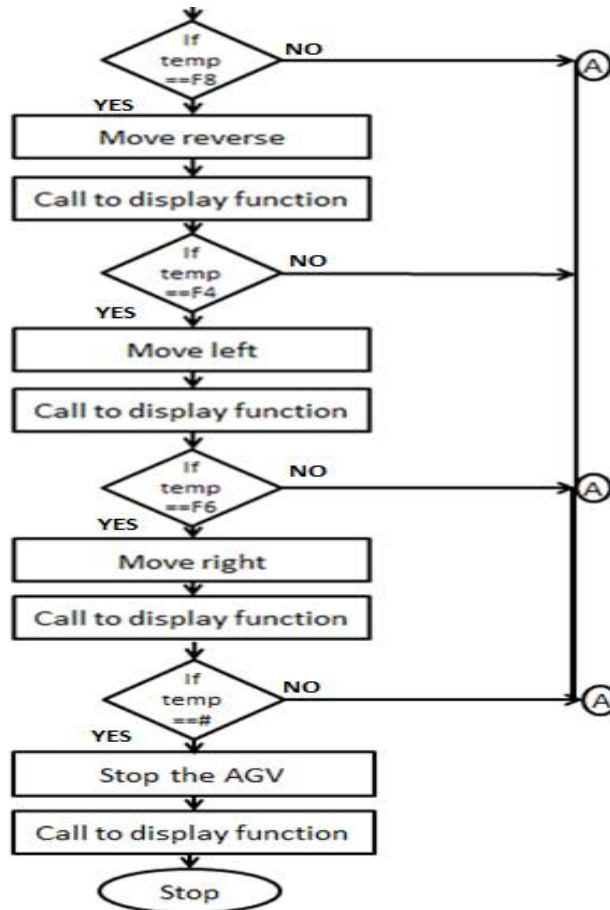

Fig6. Flowchart for Robot's Movement Control

V. EXPERIMENTAL RESULTS

The results obtained for the implementation of landmine detecting robot are tabulated below. These results can be implemented in real time and is very much significant and essential for the development of a society by allowing access to cultivable lands.



Fig7. Power Supply Unit

International Journal of Innovative Research in Science, Engineering and Technology

(An ISO 3297: 2007 Certified Organization)

Vol. 5, Issue 4, April 2016

Figure 7 shows the power supply circuit which has been fabricated to produce 5V voltage and is used to drive the motor driver circuit. The power supply circuit consists of transformer, rectifying diodes, capacitors, 7805 regulators. The voltage across each of the components is tabulated below:

The DTMF decoder output is given to the AT89C51 microcontroller which processes the binary data to signal the LM293D motor driver for the movement of the motors. There are 2 motors used in the prototype for moving the robot forward, backward, left and right. The robot chassis is balanced in front using a caster wheel which can turn in all directions. Mini posts are attached using screws to provide some height to the coil.

The logic table obtained for rotating one of the two motor in clockwise and anticlockwise direction is shown in table 1 below. The input pin has to be provided with Logic 1 and Logic 0. In a similar way, the motor can also operate across input pin 15 and 10 for the other motor.

Pin2	Pin6	Result
1	0	Clockwise
0	1	Anti-clockwise
0	0	No rotation
1	1	No rotation

Table1. Movement of Motor Based on Pin Connection

The metal detecting sensor shown in figure 8 is fabricated and with the help of this sensor, different metals can be detected and the nominal sensing range of different metals like aluminium, brass, stainless steel and iron has been calculated.



Fig8. Metal Detector Circuit

The metal detector circuit is attached in front of the robot and is used to give an analog signal to a 555 timer working as a mono-stable multi-vibrator which controls the timings for buzzer to be ON and OFF in case of presence or absence of metal respectively.

International Journal of Innovative Research in Science, Engineering and Technology

(An ISO 3297: 2007 Certified Organization)

Vol. 5, Issue 4, April 2016

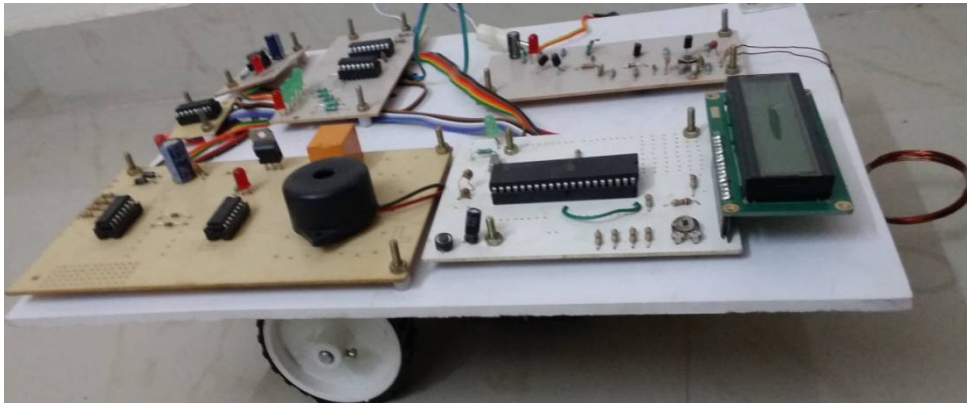

Fig9. Prototype of the Robot

Figure 9 shows the different modules of the robot which are integrated together and a complete prototype has been obtained.

VI. CONCLUSION AND FUTURE WORK

Anti-Personnel (AP) Landmines pose a serious threat to the soldiers and civilians worldwide and also provide major challenges to agriculture, flora and fauna, and infrastructure in post-conflict regions all across the world. The design implemented in this project is of a landmine detecting robot using GSM technology that is controlled by AT89C51 microcontroller. The robot is able to move in all the four directions using mobile keys and the landmine is detected using a metal detecting sensor placed on the robot. The proposed model can only detect the landmines which are metallic in nature and is unable to detect the non-metallic mines (plastic mines). The proposed system does not give any additional information about metal content of the landmine and type of landmine detected as the system lacks image processing system.

A future scope would be to install camera in the robot to survey the minefield and to give real time image to the user or human controller so that they the exact position of the landmine can be detected and can be easily diffused. In case of plastic landmine detection, the detector can be replaced by ground penetrating radar or other such detection mechanism so as to overcome the limitation of our prototype. Another future advancement in this prototype may include Shock absorbers and adjusters that can be installed to the wheels, so that the robot can run on any terrain.

REFERENCES

- [1] Achut Manandhar, Peter A. Torrione, Leslie M. Collins and Kenneth D. Morton, "Multiple-Instance Hidden Markov Model for GPR-Based Landmine Detection," IEEE transactions on Geosciences and remote sensing, vol. 53, no. 4, pp. 1737-1745, April 2015.
- [2] Sudac, D., "Improved system for inspecting minefields and residual explosives," IEEE transactions on Nuclear instrumentation, vol. 15, no. 4, pp. 108-120, June 2013.
- [3] Jaradat, M.A., "Autonomous navigation robot for landmine detection applications," IEEE transactions on Mechatronics and its Applications, vol. 16, no. 3, pp. 1-5, April 2012.
- [4] J. Rodriguez, C. Castiblanco and J. Colorado, "Low-cost quadrotor applied for visual detection of landmine-like objects," IEEE transactions on Antennas and Propagation, vol. 22, pp. 51 – 68, May 2014.
- [5] J.NICOUD and M.HABIB, "The Pemex-B autonomous demining robot: Perception and Navigation strategies", IEEE transactions on Intelligent Robots and Systems, vol. 3, pp. 419-424, Feb 2015.
- [6] J.Bagnell, F. Cavalcanti, L. Cui, T. Galluzzo, M. Hebert, M. Kazemi, M. Klingensmith, J. Libby, T. Liu, N. Pollard "An integrated system for autonomous robotics manipulation," IEEE International Conference, pp. 2955-2962, May 2012
- [7] A. Muhammad, S. Abbas, T. Manzoor, A. Munawar, S. Abbas, M. Hayat, A. Abbas, and M. Awais, "Marwa: A rough terrain landmine detection robot for low budgets", IEEE transaction on Robotics, vol. 12, no. 3, pp. 245-282, June 2012.
- [8] Lorena Cardona, Jovani Jiménez, Nelson Vanegas "Landmine Detection Technologies to face the demining problem in Antioquia", Dyna, year 81, no. 183, pp. 115-125. Medellin, February, 2014.