

Experimental Study of Reinforced Brick Masonry Structures

K.S.Sakthivel¹, S.Murugan², K.Ranjith Kumar³, G.Ranjith Kumar⁴

Assistant Professor, Department of Civil Engineering, Muthayammal College of Engineering, Rasipuram,
Tamil Nadu, India¹

Assistant Professor, Department of Civil Engineering, Government College of Technology, Coimbatore,
Tamil Nadu, India²

Assistant Professor, Department of Civil Engineering, Excel College of Engineering, Komarapalayam,
Tamil Nadu, India³

PG Student, Department of Civil Engineering, Paavai Engineering College, Namakkal, Tamil Nadu, India⁴

ABSTRACT: Brick masonry is one of the most important areas in building construction. Generally normal bricks are used for masonry works and they will collapse during earthquake disasters. Joint failure occurs in brick structures at maximum cases. To reduce the joint failure and increase the shear strength of the structures steel is embedded inside the bricks. In this project both horizontal and vertical reinforcements were provided. Three brick structures specimens were constructed by using both ordinary brick masonry and Reinforced brick masonry. Each specimen size was (495 mm * 480 mm * 110 mm). After curing the specimens were subjected to diagonal compression test using UTM and the displacement occurred corresponding to load applied was measured during the test. From the tests the average collapse load of the reinforced brick masonry was 22.487 KN which was 2.63 times more than ordinary brick masonry 8.56 KN.

KEYWORDS: T Earth quake, Reinforced brick, Horizontal reinforcement, Vertical reinforcement Diagonal compression, Shear strength

I. INTRODUCTION

Brick masonry is one of the oldest forms of building construction. Brick wall construction is commonly used for low cost dwellings in developing nations. This system, being extremely brittle, performs poorly during earthquakes. From the experience of earthquakes major damages occurred in the masonry structures. Damage of unreinforced building has caused huge number of human dead historically and during earthquakes in developing countries. It exposes that development of proper retrofitting technique for masonry buildings is the main challenge to increase seismic safety in those countries. Understanding masonry wall behaviour under lateral loads especially cyclic loads induced by earthquake ground motions is therefore important as it helps both evaluating the seismic vulnerability of existing buildings and developing proper retrofitting measures. Masonry sustains damage inform of cracks at early stage of loading as the mortar breaks out low level of load compared to brick units so it is important to capture the behavior of masonry at the cracks. Reinforcement has been used to strengthen masonry to withstand the seismic forces. The main objective of the study is to reduce the joint failure and sliding against shear by using horizontal and vertical steel reinforcements in the brick masonry, then to increase the shear strength and safety of masonry structures by providing the steel reinforcements.

International Journal of Innovative Research in Science, Engineering and Technology

(An ISO 3297: 2007 Certified Organization)

Vol. 5, Issue 4, April 2016

II. RELATED WORK

MATERIALS AND METHODS

i) Preparation of clay for bricks

The initial process of brick manufacturing was preparation of clay, it was prepared by the following manner of unsoiling, digging, cleaning, weathering, blending, tempering and finally molding. There are two types molding one is hand molding and another one is machine molding. In this study bricks are prepared by hand molding.

ii) Brick mould specifications

For ordinary bricks, the size of brick mould chamber was fabricated 230 mm X 110 mm X 80 mm. In reinforced bricks, for horizontal reinforcement a gap of 32 mm depth and 15 mm was provided at the center of brick at longitudinal section and for vertical reinforcement a gap of 32 mm long and 15 mm width was provided at the distance of 45 mm apart from both sides of brick. Fig 1 (a) shows the brick mould which was used for preparation of brick and 1 (b) illustrates the graphical view of brick specifications which has been adapted for constructing reinforced brick specimens



(a)

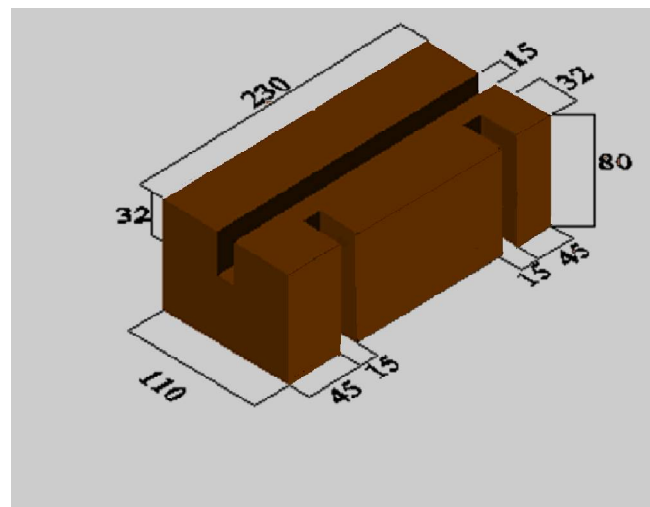

(b)

Fig 1 (a) Brick mould (b) Brick specifications

iii) Brick moulding and manufacturing

The ground was first made level and fine sand was sprinkled over it. The mould was dipped in water and placed over the ground. After that the clay was filled in the mould and top surface was leveled on the brick. Again the lump of tempered clay was taken and it was dashed in the mould. The clay was pressed in the mould in such a way that it fills all the corners of mould. The extra or surplus clay was removed. A stick was plunged into the horizontal gap and the clay was removed. Then the stick was taken out. The mold was dipped in water and it was placed just near the previous brick to prepare another brick. The process was repeated. Finally the moulded bricks were burned. The burning of bricks was done in clamps. When burning of bricks, the particles of two important constituents of clay, namely, alumina and silica bind themselves together resulting in the increase of strength and density of bricks. Kilan temperature was 1110°C. Figs 2 (a), (b), (c), (d) and (e) were shows the manufacturing processes of brick using clay in the site.

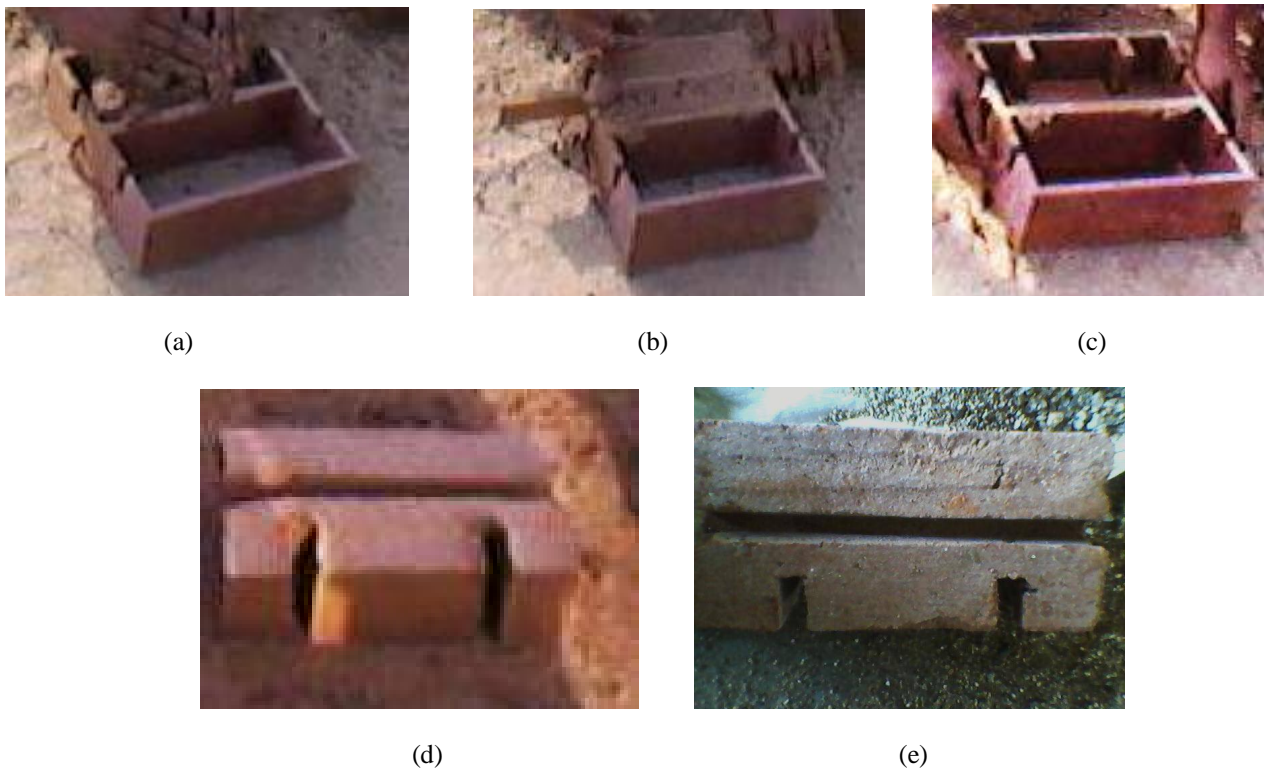
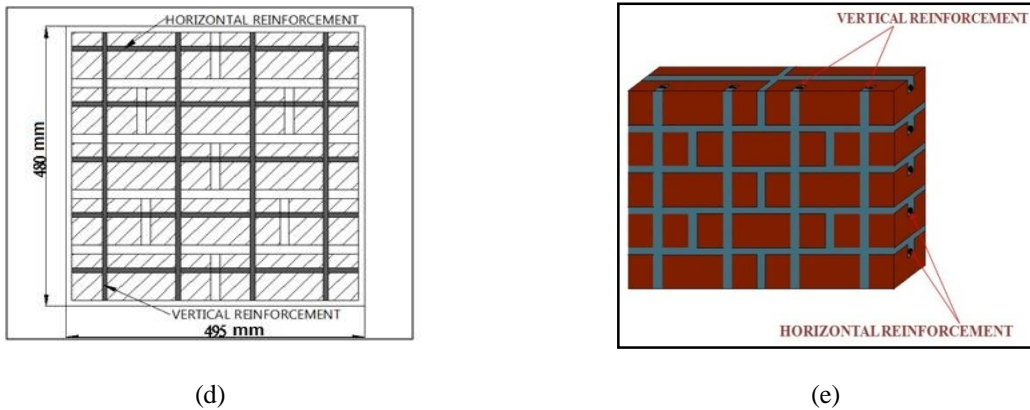

Fig 2 (a) Filling of clay (b) Plunging the stick into clay (c) Removing the mould (d) After removing (e) After burning

iv) Construction of brick masonry

In masonry works, 8 mm TMT steel bars were embedded as reinforcement, Ordinary Portland cement and 1.8 mm sieve passed sand were used in cement mortar in the ratio of 1:5. Before starting masonry work, the platform was cleaned, leveled and watered. Non permeable sheet was placed on the prepared platform. Bricks were placed on sheet and mortar was used to fill the joints for ordinary masonry specimen. In the case of steel embedded brick specimen, horizontal and vertical rods were placed during masonry works. Then mortar was applied inside the gap. The gaps between the bricks were filled with mortar. The peripheral of the masonry was finished with mortar. Both specimens were cured for 28 days to attain the strength. Figs 3 (a), (b) and (c) were demonstrates the constructing works of reinforced bricks in laboratory. The sectional view and graphical view of the constructed specimens are illustrates in figs 3 (d) and (e) respectively





Figs 3 (a) Constructing reinforced brick specimen (b) Top view of the specimen (c) Finishing work of specimen (d) Sectional view of the specimen (e) Graphical view of constructed specimen

v) Diagonal compression test

Determination of the diagonal compression test or shear strength masonry assemblages by loading them in compression along one diagonal, thus causing a diagonal tension failure with the specimen splitting apart parallel to the direction of load. The diagonal test was carried out in Universal Testing Machine (UTM). The capacity of universal testing machine is 1000 KN. The compression test, tensile strength, shear strength, flexural strength, and split tensile strength of concrete cube, steel, concrete prism, concrete cylinder, timber, brick and masonry can be estimated by the use of this equipment.

Testing of specimen

A wooden mould was used for distributing the compression load at one third distance in the specimen. Specimen was placed on the wooden mould which was located in Universal Testing Machine diagonally. Gradually load was applied on specimen assemblages by loading them in compression along one diagonal. For particular loading, the corresponding displacement readings were recorded in the computer which was attached with UTM. Load was applied up to the specimen collapsed. Graph was plotted between Load versus Displacement and the shear strength was calculated. Fig 4 shows the graphical view diagonal compression test on brick specimens.

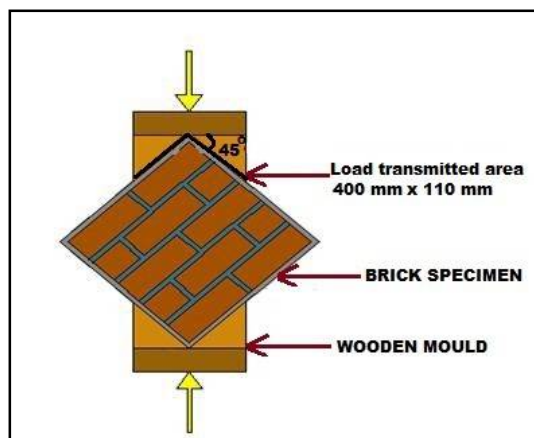

Fig 4 Diagonal Compression test graphical view

III. EXPERIMENTAL RESULTS

i) Water absorption test

Water absorption test was carried out and the absorption values were determined. Wet weight was measured by immersing of brick in water after 24 hours.

$$\text{Water absorption} = (W_2 - W_1) \div W_1 \times 100$$

Table 1 Water absorption test details

S.No	Specimen	Dry weight (W ₁) Kg	Wet weight (W ₂) Kg	Water absorption %
1	Ordinary brick	3.190	3.580	12.22
2	Reinforced brick	2.870	3.235	12.71

There was no significant difference found in water absorption of both ordinary and reinforced bricks. So both bricks were exposed the same properties against water.

ii) Diagonal compression test

Specimen details

- Specimen size : 495 mm X 110 mm X 480 mm
- Mortar : 1:5 cement and sand mortar
- Mortar thickness : 10 mm
- Reinforcement : 8 mm diameter TMT bars with horizontal length 475 mm and vertical length 460 mm.
- Load transmitting area : 400 mm * 110 mm
- Angle of inclination : 45° to the Horizontal plane (for Diagonal compression)

The specimens were tested in UTM, the load and displacements were noted. The shear strength of the masonry was computed from the UTM recorded data by using the formula

$$\text{Shear strength (KN/m}^2\text{)} = F \cdot \sin 45^\circ / A$$

F – Diagonal Compressive Load in KN

A – Load transmitted area of the specimen in sq.m (400 mm * 110 mm)

Sin 45° - Specimen is placed 45° inclined to the horizontal plane or load transmitted 45° inclined on the specimen.



(a)



(b)



(c)

Fig 5 (a) During Diagonal compression test (b) Normal brick specimen failure (c) Reinforced Brick specimen failure

International Journal of Innovative Research in Science, Engineering and Technology

(An ISO 3297: 2007 Certified Organization)

Vol. 5, Issue 4, April 2016

Figs 5 (a), (b) and (c) shows the testing of specimens under diagonal compression in UTM. During tests the ordinary specimens failure were obtained in the joints, before bearing the maximum loads by bricks the specimen was collapsed as joint failure. In the case of reinforced brick specimens due to reinforcement the joint failure was arrested and loads were carried effectively by the bricks.

Table 2 Diagonal compression test details

Specimen No	Normal Brick specimen		Reinforced Brick specimen	
	Displacement (mm)	Ultimate load (KN)	Displacement (mm)	Ultimate load (KN)
1	2.792	8.45	14.69	20.68
2	3.28	8.93	15	24.85
3	3.507	8.3	16.56	21.93
	Average	8.56	Average	22.487

From the test results graph was plotted as applied load versus corresponding displacement both ordinary brick specimens and reinforced brick specimens. Fig 6 the graph shows the behaviors of both ordinary and reinforced specimens under diagonal compression load with corresponding displacements was taken place. The carried load and consequent displacement were very high in reinforced specimen when compared with ordinary specimen. It shows that the reinforced brick possess high resistance to shear force and avoid the joint failure whereas in ordinary specimen the joint failure was occurred and it caused collapse of specimens before the load was effectively carried by the bricks.

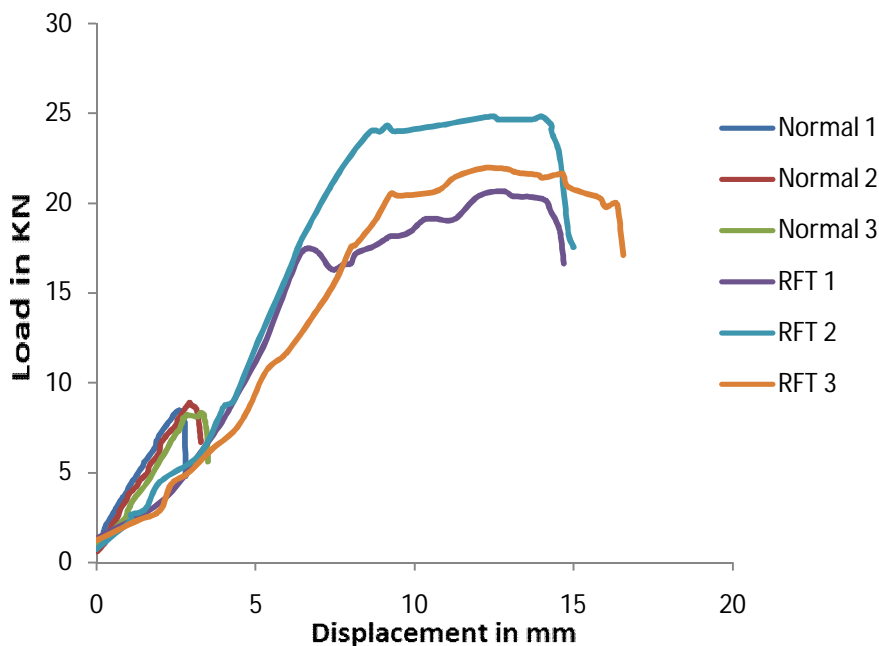

Fig 6 Load vs Displacement graph

International Journal of Innovative Research in Science, Engineering and Technology

(An ISO 3297: 2007 Certified Organization)

Vol. 5, Issue 4, April 2016

Shear stress

- | | | |
|-----|---------------------------|--|
| i. | Normal brick specimen | = $8.56 * \sin 45^0 / (0.400 * 0.110) = 137.54 \text{ KN/m}^2$ |
| ii. | Reinforced brick specimen | = $22.487 * \sin 45^0 / (0.400 * 0.110) = 361.32 \text{ KN/m}^2$ |

IV. CONCLUSION

The diagonal test was conducted on both specimens; the average collapse load of the reinforced brick masonry is **22.487 KN** which is **2.63 times** more than ordinary brick masonry and shear stress is obtained as **361.32 KN/m²** and **137.54 KN/m²** for reinforced brick masonry and ordinary brick masonry respectively. According to the result we arrive that in Reinforced brick masonry shear stress is increased. It is **263%** higher than ordinary brick masonry. Thus, we concluded that the use of steel embedded brick is one of the best solutions of brittle fracture in brick wall systems against shear. Also it withstands against seismic forces when compare to ordinary brick structure. So it can be adapted for high seismic zone buildings. We can prevent huge building structures from collapses and damages during seismic activities because these structures possess high resisting strength against seismic forces. Even though the construction cost of these kinds of reinforced brick structures is relatively high, its cost consumption is very less while comparing with the losses caused by ordinary brick structures collapses during earthquake disasters.

Based on this study brick masonry has higher shear strength if it is provided with steel reinforcement. Further study can be carried out in the same brick masonry applying cyclic load and shake table test.

REFERENCES

- [1] Indian Standard code IS 2212:1991 "Code of practice for brickworks"
- [2] Indian Standard code IS 2250:1981 "Code of practice for preparation and use of masonry mortars"
- [3] Miha Tomazevic "Earthquake Resistant Design of Masonry Buildings" World Scientific, Series on Innovation in Structures and Construction, Volume 1, 1999.
- [4] Murtyl, C. V. R., Jayanta Dutta, Agrawal, S. K., "Twin lintel belt in steel for seismic strengthening of brick masonry buildings", Earthquake Engineering And Engineering Vibration, Vol.3, No.2, December, 2004.
- [5] Jocelyn Paquettel and Michel Bruneau, "Seismic Resistance of Full-Scale Single Storey Brick Masonry Building Specimen", Austin, Texas USA June 6 – 9, 1999
- [6] Jagadish, K. S., Raghunath, S., Nanjunda Rao, K. S., "Behavior of Masonry Structures during the Bhuj Earth quake of January 2001", Proc. Indian Acad. Sci. (Earth Planet. Sci.), 112, No. 3, pp. 431-440, September 2003.
- [7] Gero Marzahn "The Shear Strength Of Dry-Stacked Masonry Walls", Dipl.-Ing., Institute of Massivbau and Baustoff technology, University Leipzig LACER No. 3, 1998
- [8] Burak Dincel "The Roles of Masonry Infill Walls in an Earthquake", Kocaeli (Turkey) August 17, 1999.
- [9] Piyong Yu and Pedro Franco Silva, "Strengthening of Infill Masonry Walls Using Bondo Grids with Polyurea", National Science Foundation's on June 2005.