

# Implementation of Fuzzy Logic Controller for PV Interfaced Grid Connected PBT Based DSTATCOM for Real and Reactive Power Control

N. Raghava<sup>1</sup>, T. Praveen Kumar<sup>2</sup>, Dr K. Sumanth<sup>3</sup>

P.G. Student, Department of Electrical & Electronics Engineering, Sreenidhi Institute of Science and Technology,  
Hyderabad, Telangana, India<sup>1</sup>

Associate Professor, Department of Electrical & Electronics Engineering, Sreenidhi Institute of Science and  
Technology, Hyderabad, Telangana, India<sup>2</sup>

Principal and Professor, Department of Electrical & Electronics Engineering, Sreenidhi Institute of Science and  
Technology, Hyderabad, Telangana, India<sup>3</sup>

**ABSTRACT:** In this paper Fuzzy logic controller for PV Interfaced Grid connected PBT (Power Balance Theory) based DSTATCOM (Distribution Static Compensator) for real and reactive power control is elaborated and implemented using 'Simpowersystem' block sets of MATLAB. Distribution system has poor power quality due to drastic increase in real and reactive power demand due to industrial as well as agricultural loads in distribution system, which has resulted in insufficient active and reactive power at load end. DSTATCOM is promising shunt connected custom power device for mitigating the power quality issues. For mitigation of active power demand at load end distributed power generation such as PV generation system is interfaced with the grid through boost converter and two level voltage source converters. In this paper Fuzzy logic controller is used for stabilization of DC link capacitor voltage. Simulation is done for implementation of proposed controller for reactive power control and performance is investigated over conventional controllers for UPF mode of operation i.e., Reactive power flow control. The simulation results shows that fuzzy logic control provides better system response and reactive power control over PI controller.

**KEYWORDS:** Power Balance Theory; Fuzzy logic control; PWM; DSTATCOM; PV generation; Reactive power control.

## I. INTRODUCTION

Energy demand is increasing drastically due to rapid industrialization and agricultural sectorial demand in rural areas. At this end most common problems faced in distribution systems are poor power quality due to usage of non-linear loads on operation of power electronic converters controlled devices in industries and house hold appliances. Also dynamic loads results in increased reactive power consumption as a consequence results in poor voltage profiles and increasing losses in the power systems, making the systems to enhance the capacity to higher MVA than required by the load. At the outset reactive power compensation at load end improves operating power factor of the utility concerned which also improves regulation and reduces losses of the entire system[1-2]. Seventy five percent of total global energy demand is supplied by burning of the fossil fuels, which results in hazardous impacts such as increasing air pollution, global warming etc. The electrical utilities today are more concerned to meet the growing demand by employing distributed power generation at concentrated and far load ends. Solar photovoltaic generation is one of the widely used renewable energy source. Different strategies are proposed in the literature for extracting maximum power from solar photovoltaic generation [3-7]. To meet the reactive power demand at the load end and also to mitigate some

# International Journal of Innovative Research in Science, Engineering and Technology

(An ISO 3297: 2007 Certified Organization)

Vol. 5, Issue 12, December 2016

of the current based power quality problems viz., harmonics and unbalance in neutral current, shunt connected custom power compensating device, such as, DSTATCOM is employed . DSTATCOM comprises of VSC (Voltage Source Converter) DC link capacitor and Interfacing inductor. Various control algorithms are proposed in literature like SRF (Synchronous Reference Frame), PBT (Power Balanced Theory), IRPT (Instantaneous Reactive Power Theory) and carrier-less based algorithms for controlling DSTATCOM [8-10]. Power balance theory is employed for the control of DSTATCOM for extraction of supply reference currents. For the operation of VSC, various pulse generation methods (Modulation techniques) are proposed in the literature viz., hysteresis controllers (Carrier less), PWM techniques and Space Vector Pulse Width Modulation (SVPWM) technique of which PWM technique is employed. For stabilizing DC link voltage across capacitor of VSC various control strategies have been adopted and proposed in literature [11-14]. For the operation of VSC, a constant DC voltage across capacitor is required and to do the needful PI controller is employed and is proposed in the literature; but to certain extent PI controller works satisfactorily and gives better results for dynamic and highly non linear loads; however the stability of the system restricts its use. In place of PI controller, a fuzzy controller is used in this paper and its performance is investigated [16-18]. At the outset, to further enhance performance of the entire system in addition to reactive power management, distributed renewable energy PV power generation system is adopted at the load end which supplies the desired real power by controlling DSTATCOM. PV generation system is interfaced to the grid through DC-DC Boost converter and 3-Phase VSC. PWM Technique is employed for operation of DC-DC Boost converter to generate the desired DC link voltage. In this paper simulation of PBT based DSTATCOM with grid connected PV generation system using fuzzy logic controller for real and reactive power control over PI controller is investigated by implementing in MATLAB. The comparative results are analysed and found that fuzzy logic controller gives better real and reactive power control and response compared to PI controller and dynamic states.

## II. SYSTEM CONFIGURATION AND CONTROL ALGORITHM

**Fig.1** shows the schematic power module for implementing PI / Fuzzy logic controller for PV Interfaced Grid connected PBT based DSTATCOM for real and reactive power control required by the linear / variable loads of distribution system in MATLAB / Simulink environment using ‘Simpowersystem’ block sets. PV generation system is developed to generate a power of 20KW which is interfaced with the grid through DC-DC Boost converter and 3-Phase diode clamped voltage source converter operated by generating pulses through carrier based PWM process. **Fig.2** shows the schematic diagram for extraction of reference supply currents using Power Balance Theory (PBT) based algorithm [2]. System development involves selection of various components for both reactive and real power compensation such as interfacing inductor, DC link capacitor, Ripple filter, selection of reference DC Voltage, and designing of PV generation system for desired power and DC-DC boost converter for boosting DC voltage [12].

### 1. Selection of DC Bus reference voltage:

The criteria for selecting DC bus voltage of VSC is that, it should be greater than twice the peak value of phase voltage of the system and as given by Eq.(1).

$$V_{dc} = \frac{2\sqrt{2} * V_{LL}}{\sqrt{3}} \quad (1)$$

### 2. Selection of interfacing Inductor:

The interfacing inductor of VSC is selected for minimizing the current ripples is given by Eq.(2).

$$L_f = \frac{\sqrt{3} * m * V_{dc}}{(12 * h * f_s * \Delta i)} \quad (2)$$

### 3. Selection of DC link capacitor:

The selection of DC link capacitor of VSC is governed by Eq.(3).

## International Journal of Innovative Research in Science, Engineering and Technology

(An ISO 3297: 2007 Certified Organization)

Vol. 5, Issue 12, December 2016

$$C_{dc} = \frac{I_{ob} * D}{(\Delta v * f_{sw})} \tag{3}$$

#### 4. Selection of ripple filter:

High pass first-order filter is used to filter out the noise from Point of Common Coupling voltage. The basis for selecting filter components is to ensure that time constant of the filter should be very small compared with the fundamental time period. Ripple filter parameters selected are  $R_f = 10\Omega$  and  $C_f = 5.5\mu\text{Farads}$ .

#### 5. Design of the Solar Photovoltaic generation:

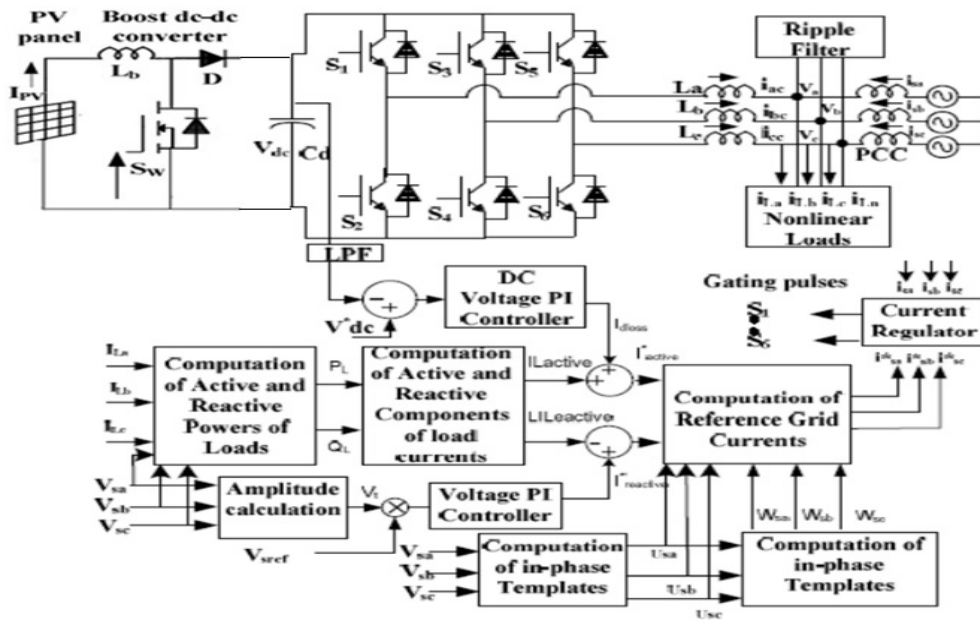
The SPV power generating system is designed for a 20kW peak power capacity. According to design considerations 14 modules in series, 10 modules in parallel, one solar module consists of 40 cells in series. Each cell has an open circuit voltage of 0.64 V and short circuit current of 3.7A.

#### 6. Design of DC-DC Boost Converter:

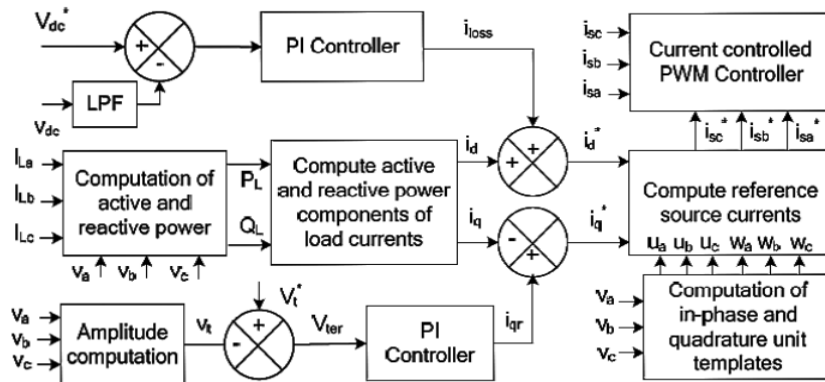
**Fig.1** shows the schematic diagram of DC-DC Boost converter. The voltage from PV cell is boosted by using DC-DC boost converter to 700V. The design parameters of the DC-DC boost converter to boost the voltage is given as

$$L_b = \frac{V_{pv} * D}{(2 * \Delta i * f_{sw})} \tag{4}$$

Where D is duty cycle ( $D = 1 - (V_{in} / V_o)$ ). This converter boosts the voltage of SPV array from  $V_{in} = V_{pv} = 360V$  &  $V_o = 700V$ . The calculated value of D is 0.485 and is output voltage from PV array.  $\Delta i$  is input current ripple and for this converter design, the value of  $\Delta i$  is considered 10% of input current,  $f_{sw}$  is switching frequency and the value of  $f_{sw} = 10\text{ kHz}$ . The value of inductance ( $L_b$ ) from Eq. (1) is obtained as 1.5 mH.



**Fig.1: Schematic diagram of grid interfaced solar PV power generating system through boost DC-DC converter and two-level VSC based DSTATCOM**



**Fig. 2: The Schematic diagram of Fuzzy logic controlled PBT based DSTATCOM control algorithm for extracting reference source**

Instantaneous active and reactive power of the load are estimated by using Eq.(5)

$$\begin{aligned}
 p_L &= V_{sa} i_{sa} + V_{sb} i_{sb} = V_{sc} i_{sc} \\
 Q_L &= \frac{1}{\sqrt{3}} \{ (V_{sa} - V_{sb}) i_{LC} + (V_{sb} - V_{sc}) i_{La} + (V_{sc} - V_{sa}) i_{LCb} \}
 \end{aligned}
 \tag{5}$$

Instantaneous active and reactive components of load current consist of DC as well AC components as seen noticed from Eq.(6) where fundamental components of load active and reactive powers are extracted using low pass filters.

## International Journal of Innovative Research in Science, Engineering and Technology

(An ISO 3297: 2007 Certified Organization)

Vol. 5, Issue 12, December 2016

$$p_L = p_{LDc} + P_{LAC}$$

$$Qp_L = Q_{LDc} + Q_{LAC} \quad (6)$$

Fundamental real and reactive power components of load currents are extracted using Eq.(7).

$$I_{LpDC} = \left(\frac{2}{3}\right) (P_{LDc} / V_{Sp})$$

$$I_{LqDC} = \left(\frac{2}{3}\right) (Q_{LDc} / V_{Sp}) \quad (7)$$

Amplitude of active and reactive power components of reference supply currents are estimated by adding output of PI/FIS controllers to the fundamental real and reactive power components of load current shown by Eq.(8).

$$I_{spDC} = I_{Loss} + I_{LpDC}$$

$$I_{sqDC} = I_{qDSTAT} - I_{LqDC} \quad (8)$$

Instantaneous value of fundamental three phase active and reactive power components of reference supply currents are estimated by using Eq.(9).

$$i_{sap}^* = U_{sa} I_{spDC}$$

$$i_{sbp}^* = U_{sb} I_{spDC}$$

$$i_{scp}^* = U_{sc} I_{spDC}$$

$$i_{saq}^* = U_{saq} I_{sqDC}$$

$$i_{sbq}^* = U_{sbq} I_{sqDC}$$

$$i_{scq}^* = U_{scq} I_{sqDC} \quad (9)$$

Instantaneous fundamental reference supply currents are estimated by adding fundamental in-phase and quadrature reference supply currents as given Eq.(10).

$$i_{sa}^* = i_{sap}^* + i_{saq}^*$$

$$i_{sb}^* = i_{sbp}^* + i_{sbq}^*$$

$$i_{sc}^* = i_{scp}^* + i_{scq}^* \quad (10)$$

Pulses are generated for the operation of VSC by comparing triangular carrier waves with high switching frequency of 10K Hz with generated modulating reference signals in UPF mode of operation for reactive power control .

# International Journal of Innovative Research in Science, Engineering and Technology

(An ISO 3297: 2007 Certified Organization)

Vol. 5, Issue 12, December 2016

## III. FUZZY LOGIC CONTROLLER

A fuzzy logic controller (FLC) consists of four stages of interfacing mechanism in operation, which are a fuzzification interface, a rule base, an inference mechanism, and a defuzzification interface. It is a common practise to use error ( $e$ ) and the rate of change of error ( $e'$ ) as controller inputs. In fuzzy logic based DC voltage control across DC link, the capacitor voltage deviation and its derivative are considered as the inputs of the FLC and the real power ( $P$ ) requirement for voltage regulation is taken as the output of the FLC. The input and output variables are converted into linguistic variables. The following seven variables are considered, they are NL (Negative Large), NM (Negative Medium), NS (Negative Small), ZE (Zero), PS (Positive Small), PM (Positive Medium) and PL (Positive Large).

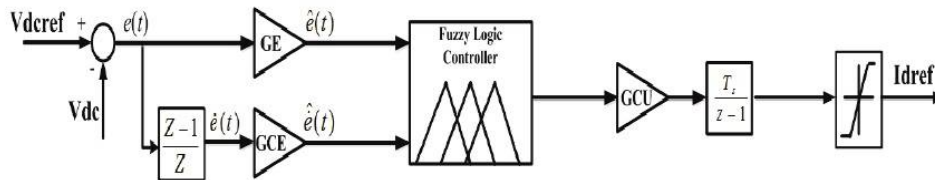


Fig.3: Schematic diagram for implementation of Fuzzy Logic Controller

The above linguistic quantification has been used in this paper to specify a set of rules or a rule-base. The rules are formulated from practical experience. For the FLC with two inputs and seven linguistic values for each input, there are  $7^2 = 49$  possible rules with all combination for the inputs [13-15]. The tabular representation of the FLC rule base (with 49 rules) for fuzzy control based DC voltage regulator is shown in **Table-1**.

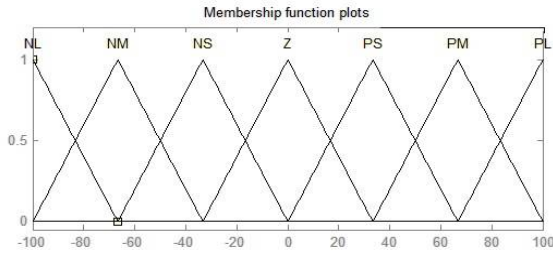
In place of PI controller of **Fig.2** proposed Fuzzy logic controller is implemented to observe the performance of DSTATCOM.

TABLE-1: 7 × 7 FLC RULE - BASE

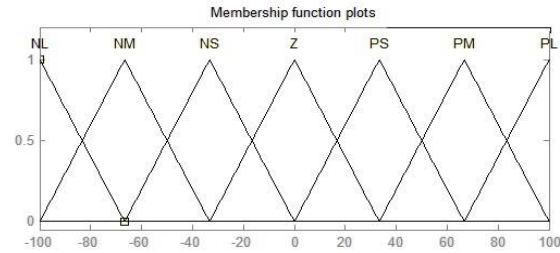
Error/Change In error	NL	NM	NS	ZO	PS	PM	PL
NL	ZO	PS	PM	PL	PL	PL	PL
NM	NS	ZO	PS	PM	PL	PL	PL
NS	NM	NS	ZO	PS	PM	PL	PL
ZO	NL	NM	NS	ZO	PS	PM	PL
PS	NL	NL	NM	NS	ZO	PS	PM
PM	NL	NL	NL	NM	NS	ZO	PS
PL	NL	NL	NL	NL	NM	NS	ZO

Triangular membership function is considered for output as well as input variables. The membership functions for the inputs and the output of the fuzzy controller for the DC voltage regulator are shown in following **Fig.4**, **Fig.5** and **Fig.6** respectively.

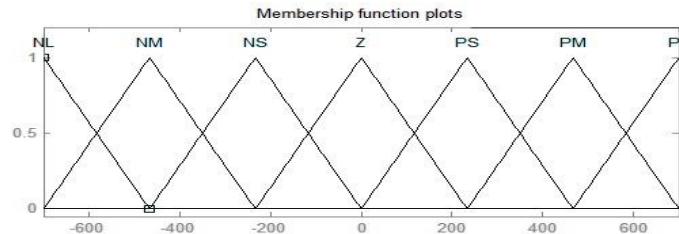




**Fig. 4: Membership functions considered for scaling input error  $e(t)$**



**Fig.5: Membership functions considered for scaling the rate of change of error  $\dot{e}(t)$**



**Fig. 6: Membership functions considered for scaling output**

#### IV. RESULTS

In this section simulation results pertaining to implementation of fuzzy logic controller for PV interfaced grid connected PBT based DSTATCOM for real and reactive power control are presented and also investigated over PI controller. In **Fig.7** it is observed that load phase voltage and current are out of phase due to the nature of the load. From **Fig.8(a-b)** it is observed that source phase voltage and current are in phase with PI as well as Fuzzy logic controlled PV interfaced grid connected PBT based DSTATCOM but current delivered by the source with FIS controlled DSTATCOM is less in comparison with PI based DSTATCOM as a result losses in the system and regulation of the system improves also stability of the system in terms of DC voltage regulation across DC bus capacitor is improved. **Fig.9** shows that the active power supplied from the source with DSTATCOM using fuzzy logic controller in comparison with PI Controller is found to be very less & the same can be observed from **Table-2**. The **Fig.10** shows that the reactive power supplied from the source with DSTATCOM using fuzzy logic controller in comparison with PI Controller is found to be very less & the same can be observed from **Table-2**. It is also observed from the **Fig.11** that with fuzzy controlled DSTATCOM, the current supplied from the source is 32.4 Amps in comparison with load current of about 46.69 Amps, which depicts the reactive power control at load the additional current is partly supplied by the PV generation system and also due to reactive power control of DSTATCOM. From **Fig.11** it is observed that Total Harmonic Distortion (THD) of source current with fuzzy logic controller based DSTATCOM is 1.5%. The data considered for system development and for MATLAB simulations are given in **Appendix-I**.

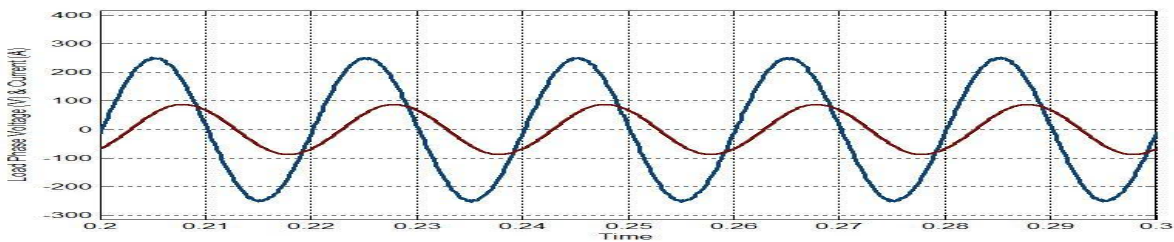
## International Journal of Innovative Research in Science, Engineering and Technology

(An ISO 3297: 2007 Certified Organization)

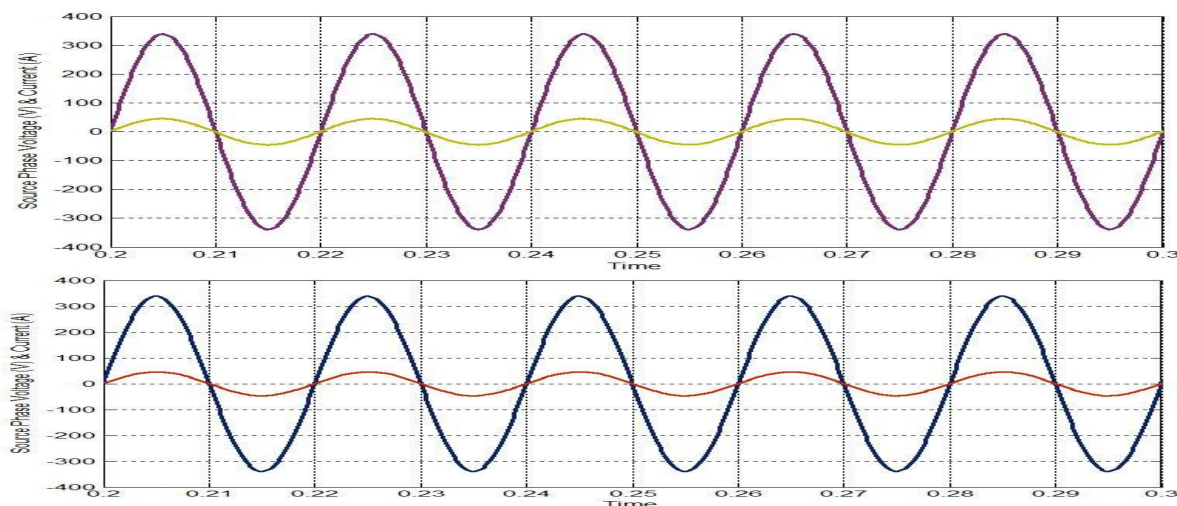
Vol. 5, Issue 12, December 2016

**Table-2: Active and reactive power comparisons of PBT based DSTATCOM with grid connected PV generation system using PI & fuzzy logic controller for active and reactive power control**

DSTATCOM control strategies	Active & Reactive power required by the Source	Active & Reactive power supplied by Load	Active & Reactive power supplied by the Inverter
PI tuned PBT based DSTATCOM With PV generation System	22828.850 W & -301.000 VAR	21714.650 W & 24444.000 VAR	-4947.360 W & -36633.000 VAR
FLC tuned PBT based DSTATCOM With PV generation System	23575.000 W & 0.000 VAR	21089.120 W & 23723.000 VAR	-3981.332 W & -34055.940 VAR



**Fig.7: The Load Phase voltage & current with PV Interfaced grid connected PBT based PI controlled DSTATCOM**



**Fig 8(a-b): The Source Phase voltage & current with PV Interfaced grid connected PBT based DSTATCOM**



# International Journal of Innovative Research in Science, Engineering and Technology

(An ISO 3297: 2007 Certified Organization)

Vol. 5, Issue 12, December 2016

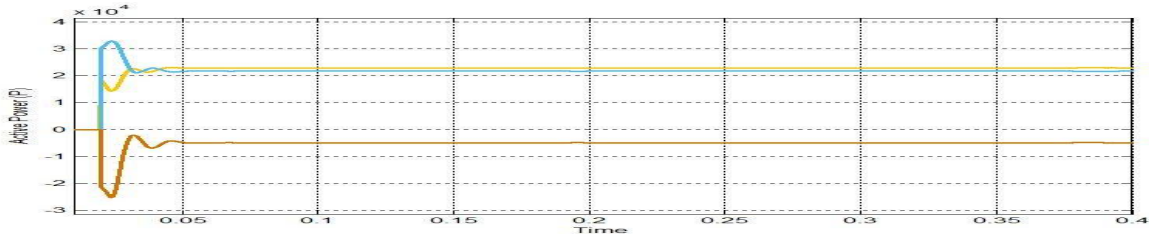


Fig 9(a-b): The Real power flow in the system with PV Interfaced grid connected PBT based PI controlled DSTATCOM

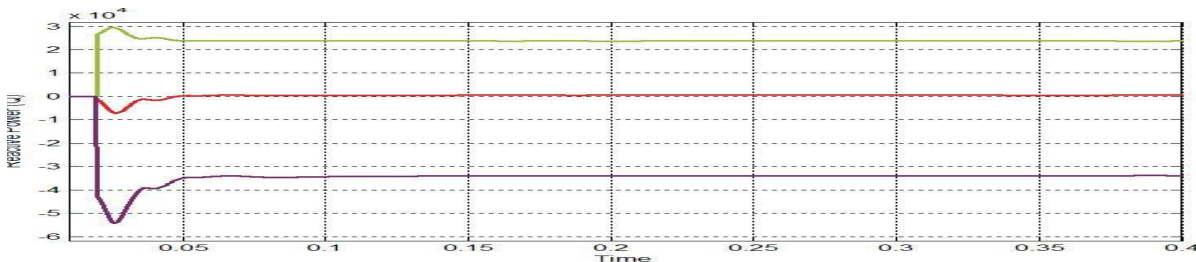
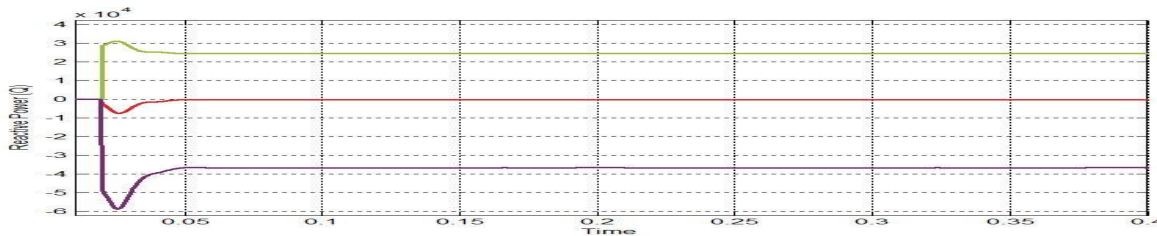


Fig 10(a-b): The Reactive power flow in the system with PV Interfaced grid connected PBT based PI controlled DSTATCOM

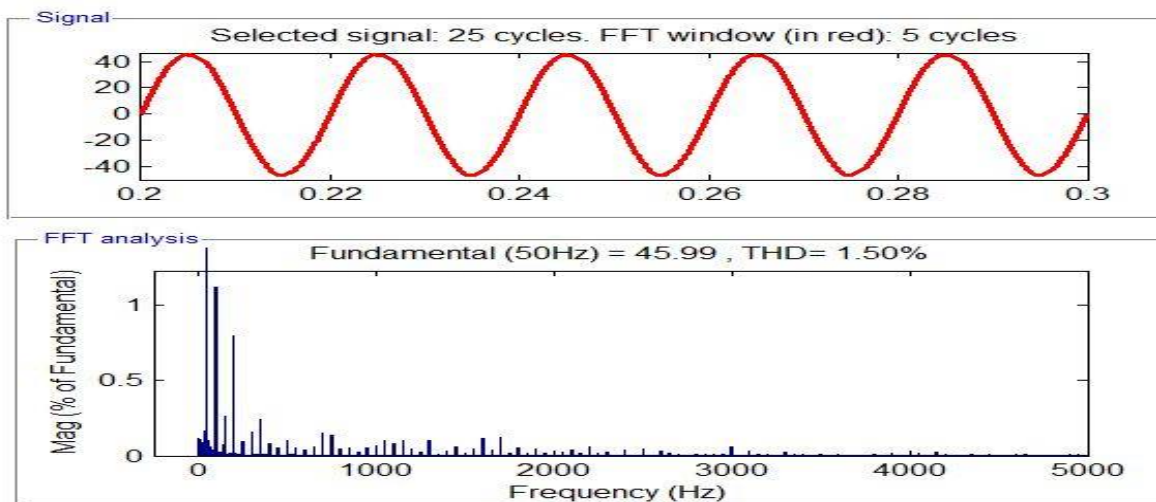


Fig.11: Waveform and Harmonic Analysis of source line current with Fuzzy Logic Controller

# International Journal of Innovative Research in Science, Engineering and Technology

(An ISO 3297: 2007 Certified Organization)

Vol. 5, Issue 12, December 2016

## V. SUMMARY AND CONCLUSIONS

In this paper simulations pertaining to PI and Fuzzy controlled PV Interfaced Grid PBT based DSTATCOM using MATLAB / Simulink for both real and reactive power control are implemented and performance is investigated. From the above discussed results it is clear that the performance of Fuzzy controlled PBT based DSTATCOM for UPF mode of operation i.e., reactive power control over PI controlled PBT based DSTATCOM is found to be more satisfactory in respect of improvement in Total Harmonic Distortion of source current and both active & reactive power control. Solar PV generating system at distributed end supplies the required real power to the load, which relays on output voltage of VSC and also supplies losses occurring in VSC. The performance of the algorithm for dynamic loads are found to be satisfactorily with regard to system stability.

### Appendix-I

#### Data considered for System Development and for MATLAB simulations

Grid voltage & grid frequency	230V+ and 50Hz respectively
PV Open circuit voltage ( $V_{OC}$ )	0.64 V
PV Short circuit current ( $I_{SC}$ )	3.4 A
One module of PV in series	40 Nos
Total Number of modules in series & Parallel	14 & 10 Nos
Source Impedence	$R_s=2\Omega, L_s = 1mH$
Interfacing Inductor	5mH
Ripple Filter	5 $\Omega$ , 10mH
DC-Link capacitor	700 $\mu$ F
Duty Cycle of Boost converter	0.4857
FLC Scaling Factors for the DC Voltage Regulator	GE =0.00319; GCE =1.7778; GCU =0.53559
$K_p$ & $K_i$	1.5 & 2.4
Load	40KW, 30KVAR

### REFERENCES

- [1] "Reactive Power Management" by D.M.Tagare, Tata McGraw Hill Publication, 2004.
- [2] "Power Quality Problems and Mitigation Techniques", by Bhim Singh, Ambrish Chandra and Kamal-al-haddad, Wiley publications, 2-----
- [3] "Basic Model and Governing Equation of Solar Cells used in Power and Control Applications" by Afshin Izadian, Arash Pourtaherian and Sarasadat Motahari, IEEE Conference of Energy Conversion Congress and Exposition (ECCE), 2012.
- [4] "MATLAB-Based Modeling to Study the Effects of Partial Shading on PV Array Characteristics", IEEE Transactions On Energy Conversion, Vol. 23, No. 1, March 2008.
- [5] "Photovoltaic Maximum Power Point Tracking Employing Load Parameters", by D.Shmilovitz, IEEE Conference, ISIE 2005, June 20-23, 2005.
- [6] "Mathematical Modeling of Photovoltaic Module with Simulink", by N. Pandiarajan and Ranganath Muthu, International Conference on Electrical Energy Systems (ICEES 2011), January 3-5, 2011.
- [7] "MATLAB / Simulink PV Module Model of P&O And DC Link CDC MPPT Algorithms with Lab view Real Time Monitoring And Control Over P&O Technique" by Williams K. Francis, Shanifa Beevi S and Johnson Mathew, International Journal of Advanced Research in Electrical, Electronics and Instrumentation Engineering, Vol. 3, Special Issue 5, December 2014.
- [8] "Power Quality Improvement by using DSTATCOM", by P. Bapaiah, International Journal of Emerging Trends in Electrical and Electronics (IJETEE), Vol. 2, Issue. 4, April 2013.
- [9] "A Comparison of Control Algorithms for DSTATCOM", by Bhim Singh and Jitendra Solanki, IEEE Transactions on Industrial Electronics, Vol. 56, No. 7, July 2009.
- [10] "Dstatcom control algorithms: A review", by Ambarnath Banerji, SujitK Biswas and Bhim Singh, International Journal of Power Electronics and Drive Systems, Vol.2, No.3, Sep.2012.
- [11] "Modified Power Balance Theory for Control of DSTATCOM", by Bhim Singh and Sunil Kumar, Power India Joint International Conference on Power Electronics, Drives and Energy Systems (PEDES), 20-23 December, 2010.

## International Journal of Innovative Research in Science, Engineering and Technology

*(An ISO 3297: 2007 Certified Organization)*

**Vol. 5, Issue 12, December 2016**

- [12] "PBT Based Control of Grid Interfaced Solar Photovoltaic Power Generating System with Improved Power Quality", by Arun Kumar Verma, Bhim Singh & D.T Shahani, IEEE Conference on Power Electronics, Drives and Energy Systems 16-19 December 2012, Bengaluru, India.
- [13] "A generalised direct approach for designing fuzzy logic controllers in Matlab /Simulink GUI environment", by Ismail H. Altas and Adel M. Sharaf, a paper accepted for publication in International Journal of Information Technology and Intelligent Computing (IJITIC), No.4, Vol 1, December 2016..
- [14] "Performance Enhancement of PBT Based DSTATCOM Using Fuzzy Logic Controller", by K. Goutham Kumar, T. Praveen Kumar and Dr. K. Sumanth, International Journal of Research in Engineering & Advanced Technology (IJREAT), Volume 4, Issue3, June - July, 2016.
- [15] "Simulation of SRF Based DSTATCOM With Grid Connected PV Generation System Using Fuzzy Logic Controller For Reactive Power Management", by R. Deepak Singh, T. Praveen Kumar and Dr. K. Sumanth, International Journal of Advanced Research in Electrical, Electronics and Instrumentation Engineering, Vol. 5, Issue 7, July 2016.
- [16] "Fuzzy Gain Scheduling of PID Controllers", IEEE Transaction on System man, andCybernetics, Vol.23. No. 5, September/October 1993.
- [17] "Enhancement of Power Quality with ANFIS Controlled DSTATCOM in Four Wire Three Phase Distribution System" by R.V.Murali, K.Srinivasu and L.V.NarasimhaRao, Biennial International Conference on Power & Energy System towards Sustainable Energy (PESTSE), 2016.
- [18] "Fuzzy Logic Control of DSTATCOM for Improving Power Quality & Dynamic Performance" by Juan Shi, Amin Nshdi, Akhtar Kalam and Peng Shi, IEEE Power Engineering Conference (AUPEC), held at Australasian Universities, Wollongong, 2016.