

PD Analysis in Cylindrical Void With Respect To Geometry of the Void

C Sunil Kumar¹, Dr. B. Ramachandra², Manohara H C³

Assistant Professor, Department of E&E, PESCE, Mandya, Karnataka, India¹

Professor & HOD, Department of E&E, PESCE, Mandya, Karnataka, India²

Assistant Professor, Department of E&E, PESCE, Mandya, Karnataka, India³

ABSTRACT: Partial discharge is an important phenomenon to be considered while studying insulation failure. Analysing PD characteristics and the detection of PD activity will help in improving the performance of insulator. In high voltage power system it is necessary to monitor the PD activity inside an insulator continuously. As the applied voltage increases the PD activity increases as the electric stress across the void becomes more than the electric stress across an equivalent distance of dielectric [1]. The deterioration depends on the applied voltage and the number of discharge [2]. In this work an electric circuit model of an epoxy resin with void of cylindrical shape is considered for realization of partial discharge activity inside the insulator with the application of high voltage using MATLAB Simulink environment. The results obtained with variation in the parameters of the void such as radius, height and volume of the cylindrical void as an impurity is analysed.

KEYWORDS: Partial discharge (PD), void, High voltage (HV), C_a , C_b , C_c , r-radius and h-height.

I. INTRODUCTION

Solid dielectrics or insulation get damaged when breakdown occurs. There are various mechanisms in which breakdown occurs. In case of partial discharge, the continuous discharge causes progressive deterioration and ultimate failure [3]. The deterioration depends upon the applied voltage and number of discharge [2]. According to IEC (International Electro technical Commission) Standard 60270, *Partial discharge is a localized electrical discharge that only partially bridges the insulation between conductors and which may or may not occur adjacent to a conductor* [1]. PD activity affects the performance of the insulator used. Therefore, it is very important to analyze the various failure mechanisms in case of solid dielectric through non-destructive testing mechanism. Detection of discharges can be made through various methods. The geometry of void present inside the insulation affects the PD activity by creating a weak zone [5]. In this work, an electrical circuit model of an epoxy resin as an insulator with a void of cylindrical shape is considered for the analysis of PD activity inside the insulator with the application of high voltage using MATLAB Simulink software, as shown in figure 2. In this study, apparent charge transfer with respect to variation in the dimensions of the void (r, height and volume), PD amplitude with variation in the dimensions of the void for both positive and negative half cycle of the applied voltage is studied. Also the rise and fall time of the PD pulse are calculated and frequency content of the observed PD pulse is studied. The results obtained with cylindrical void as an impurity is analysed so as to determine the effect of geometry of cavity or void on PD activity.

II. RELATED WORK

1. Continuous monitoring of PD activity is essential to ensure the effective performance of the insulator. From [5], the variation of apparent charge transfer with variation in the dimensions (l , b , t and volume) of the void, PD amplitude with variation in the dimensions of the void is studied. It is observed that the relation of apparent charge vs the variation of void dimension is linear one. The magnitude of internal discharges increases with increasing cavity dimensions. It is observed that the maximum amplitude of PD pulse increases in positive half cycle and decreases in negative half cycle as the dimension of the void varies. Thereby the PD activity depends on the dimensions of the void. Rise time (t_r), fall time (t_f) and pulse width of the PD pulses are calculated.

International Journal of Innovative Research in Science, Engineering and Technology

(An ISO 3297: 2007 Certified Organization)

Vol. 5, Issue 12, December 2016

2. Detection and measurement of partial discharge is necessary to ensure reliable operation of equipment. From [7], the maximum amplitude of PD, PD pulses at different applied voltages, number of PD's with respect to phase angle, apparent charge transfer for different applied voltages and frequency content of the observed PD pulse is studied. The results obtained with cylindrical and cubical void as an impurity is compared and analysed. It is observed that the amplitude of PD is maximum in case of cubical void when compared to cylindrical void when the dimensions of void is considered as specified. It is found that with increase in applied voltage across the void charge also increases linearly. The frequency content of PD pulse is also random.

3. Partial discharge is the main problem in high voltage power equipment system. Therefore, detection and measurement of partial discharge is necessary to keep the equipments in healthy condition during their operation. From [8], with increase in applied voltage across the void, partial discharge increases. This study is employed to find out the maximum partial discharge, Charge transfer with respect to applied voltage, Number of PD pulses with respect to phase angle, Number of PD pulses for different applied voltage.

III. SAMPLE PREPARATION

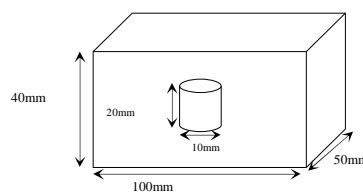

Fig 1: Void model of epoxy resin insulator with cubical void

As the electrical circuit model consists of three capacitors the values of these capacitors are calculated by following equations [8].

Formulas for Cylindrical void:

$$C_a = \frac{\epsilon_0 \times \epsilon_r \times (a - 2r) \times b}{c}, C_b = \frac{\epsilon_0 \times \epsilon_r \times r^2 \times \pi}{c - h}, C_c = \frac{\epsilon_0 \times r^2 \times \pi}{h}$$

Where ϵ_0 = Absolute permittivity
 ϵ_r = Relative permittivity

The values of capacitance are calculated from the equations specified above.

IV. EXPERIMENTAL SETUP

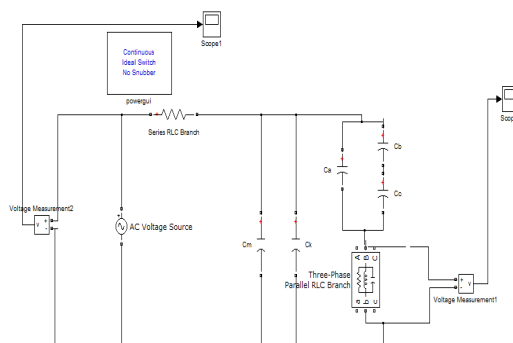

Fig 2: Simulink model

International Journal of Innovative Research in Science, Engineering and Technology

(An ISO 3297: 2007 Certified Organization)

Vol. 5, Issue 12, December 2016

The calculated capacitance values are required to get desired partial discharge characteristics. Here an equivalent circuit of solid insulator having a cylindrical shape void is taken to evaluate the partial discharge characteristics. The Simulink model for detecting partial discharge characteristics is shown in figure 2.

C_a , C_b and C_c together constitutes test object. Where capacitor C_c represents capacitance of the void in the test object. Capacitor C_b represents capacitance of the healthy part connected in series with the void. Capacitor C_a represents the capacitance of the healthy part leaving C_c and C_b . C_m refers to the measuring capacitor and C_k refers to the coupling capacitor.

The model drawn in Fig.2 is simulated using MATLAB. When high voltage is applied across the test object, voltage across the dielectric V_a increases thereby the voltage V_c across the cavity also increases. When V_c reaches inception voltage, discharge in the void occurs. The voltage across the sample at which discharges begin to occur is called Inception voltage. In Fig 2 the partial discharge pulses in μv are seen in Scope2 which is connected through voltage measurement 1 across matching impedance. The applied input voltage is measured through voltage measurement 2 and witnessed in scope 1[5]. In this study the value of the HV equipment used for the measurement of PD inside the solid insulation is taken as depicted in table1.

Sl. No	Parameter	Symbol	Value	Dimension
1	HV measuring capacitor	C_m	1000	pF
2	Coupling capacitor	C_k	1000	μF
3	Permittivity	ϵ_o	8.85×10^{-12}	F/m
4	Relative permittivity	ϵ_r	3.5	-
5	Resistance	R	50	Ω
6	Inductance	L	0.60	mH
7	Capacitance	C	0.45	μF

Table1: Parameters used for simulation

V. RESULT AND DISCUSSIONS

Charge Transfer:

Voltage across the void (V_c) is measured and applied to a subsystem in MATLAB simulink created as per the formula below.

Voltage across the cylindrical void C_c is given by

$$V_c = \frac{V_a \times C_b}{C_a + C_b} \quad [3]$$

The apparent charge transferred is calculated by $Q = C_b \times V_c$

PD activity is not directly measurable therefore apparent charge method is used. According to IEC 60270 apparent charge q of a PD pulse is that charge which if injected in a short time between the terminals of a test object in a specified test circuit, would give the same reading on the measuring instruments as the PD current pulse itself [1]. The apparent charge is usually expressed in pico Coulombs. Figure 3, 4 shows the relation between apparent charge and variation in radius of the void where the height of the void is kept constant ($h=20mm$) at the applied voltage being 5kV.

International Journal of Innovative Research in Science, Engineering and Technology

(An ISO 3297: 2007 Certified Organization)

Vol. 5, Issue 12, December 2016

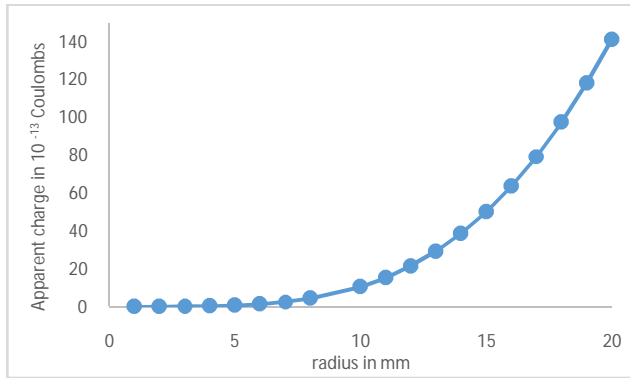

Fig 3: Variation of apparent charge for different radius (1mm to 20mm) of void keeping h constant(h=20mm) .

It is observed from Fig 3 that, when the radius of void is varied from 1mm to 20mm charge has increased from 1.3907×10^{-15} C to 1.4125×10^{-11} C and the curve is slightly parabolic in nature.

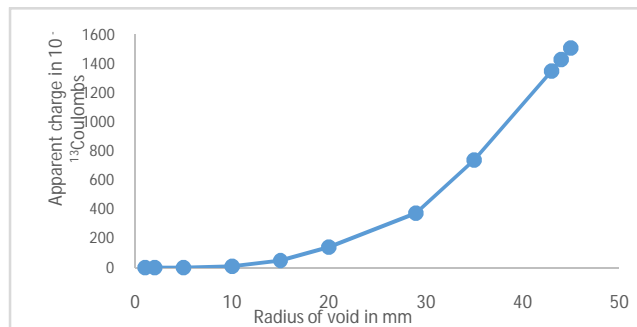

Fig 4: Variation of apparent charge for different radius (1mm to 45 mm) of void keeping h constant(h=20mm) .

It is observed from Fig 4 that, when the radius of void is varied from 1mm to 45mm the curve is parabolic up to 30mm. As the radius of the void is increased beyond 30mm the curve is linear and the rate of charge transfer is higher.

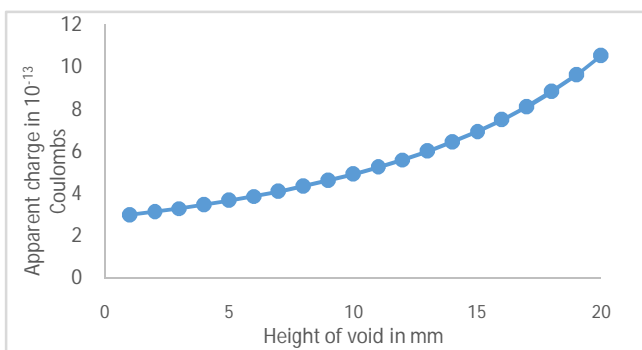

Fig 5: Variation of apparent charge for different height (1mm to 20mm) of the void keeping r constant(r=10mm).

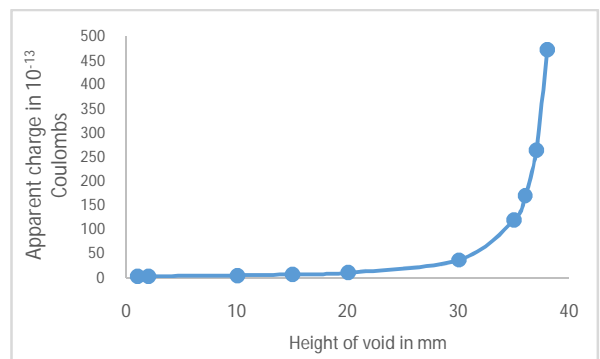

Fig 6: Variation of apparent charge for different height (1mm to 38mm) of the void keeping r constant(r=10mm).

International Journal of Innovative Research in Science, Engineering and Technology

(An ISO 3297: 2007 Certified Organization)

Vol. 5, Issue 12, December 2016

Figure 5, 6 shows the relation between apparent charge and variation in height of the void where the radius of the void is kept constant($r=10\text{mm}$) at the applied voltage being 5kV .

It is observed from Fig 5 that, when the height of void is varied from 1mm to 20mm charge has increased from $8.8846 \times 10^{-13}\text{C}$ to $1.051 \times 10^{-12}\text{C}$ and the curve is slightly parabolic in nature. However, the observation from Fig 6 is that as the height of the void is increased beyond 30mm there is a rapid increase in charge transfer compared to the region where the height of the void is less than 30mm .

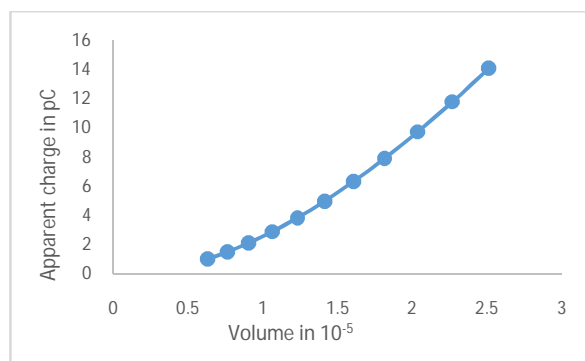

Fig 7: Variation of apparent charge for different volume of the void

Figure 7 shows relation between apparent charge and volume of the void. It is observed that the apparent charge transfer increases as the volume of void increases and the curve is almost linear.

The variations in the apparent charge transfer with respect to the dimensions of the void that is r , h and volume is as shown in figure 3, 4, 5 and 6. It is observed that as the applied voltage increases, the apparent charge transferred increases [6].

PD Amplitude:

Figure 8 and 9 represents the variation of maximum PD amplitude in case of positive half cycle and negative half cycle of the applied voltage with respect to variation in r and h of the void. It is clear from the figures that the dimensions of the void affects the PD amplitude. It is also observed that the maximum amplitude of PD pulse increases in positive half cycle and decreases in negative half cycle as the dimension of the void varies.

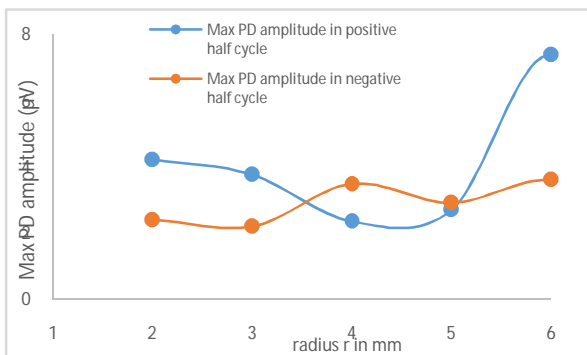

Fig 8: Variation of PD amplitude for different radius of the void keeping h constant($h=20\text{mm}$).

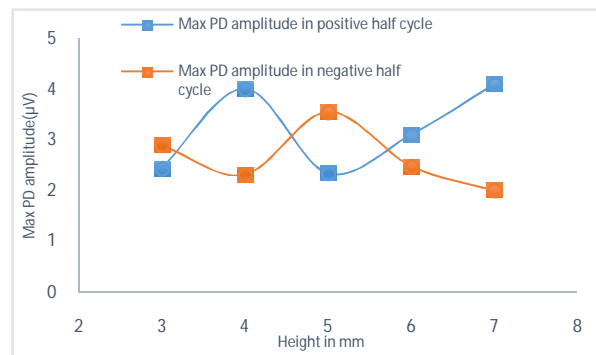

Fig 9: Variation of PD amplitude for different height of the void keeping r constant($r=10\text{mm}$).

Rise Time (t_r) & Fall Time (t_f):

The t_r , t_f and pulse width of the output pulses are calculated by considering six PD pulses, out of which three pulses are in positive half cycle and three pulses are in negative half cycle as shown in figure 10. Figure 10 represents the output PD pulses at 5 kV of applied voltage.

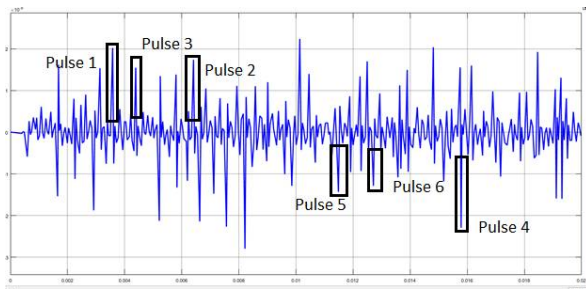

Fig 10: Output PD pulses at 5kV of applied voltage

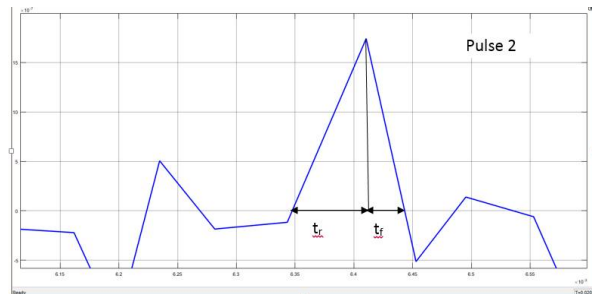

Fig 11: Rise time and fall time of PD pulse 2 in positive half cycle

The calculated rise time, fall time and pulse width of PD pulses considered in positive half cycle are depicted in Table 2. The t_r and t_f of pulse 2 is depicted in figure 11. The calculated rise time of the pulse 2 is 60μsec, the duration of rise time is between 6.35×10^{-3} - 6.41×10^{-3} sec. The calculated fall time is 30μsec and duration of fall time is between 6.41×10^{-3} - 6.44×10^{-3} . The pulse width of that pulse is the addition of rise time and fall time i.e. 90 microsecond.

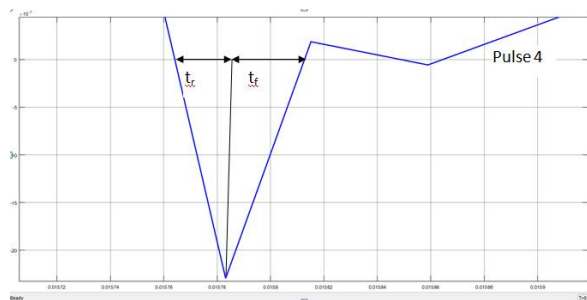

Fig 12: Rise time and fall time of PD pulse 4 in negative half cycle

The calculated rise time, fall time and pulse width of PD pulses considered in negative half cycle are depicted in Table 3. The t_r and t_f of pulse 4 is depicted in figure 12. The calculated rise time of the pulse 4 is 22μsec, the duration of rise time is between 0.01576-0.015782sec. The calculated fall time is 28μsec and duration of fall time is between 0.015782-0.01581sec. The pulse width of pulse 4 is addition of rise time and fall time i.e. 40 microsecond.

Pulse no	Duration of rise time(sec)	Rise time (μsec)	Duration of fall time(sec)	Fall time (μsec)	Total time (μsec)
1	3.51×10^{-3} - 3.58×10^{-3}	70	3.58×10^{-3} - 3.61×10^{-3}	30	100
2	6.35×10^{-3} - 6.41×10^{-3}	60	6.41×10^{-3} - 6.44×10^{-3}	30	90
3	4.34×10^{-3} - 4.385×10^{-3}	45	4.385×10^{-3} - 4.415×10^{-3}	30	75

Table 2: Rise time (t_r) and fall time (t_f) of identified pulses at 5kV of applied voltage in positive half cycle.

International Journal of Innovative Research in Science, Engineering and Technology

(An ISO 3297: 2007 Certified Organization)

Vol. 5, Issue 12, December 2016

Pulse no	Duration of rise time(sec)	Rise time (μsec)	Duration of fall time(sec)	Fall time (μsec)	Total time (μsec)
4	0.01576-0.015782	22	0.015782-0.01581	28	40
5	0.01142-0.011485	65	0.011485-0.01152	35	100
6	0.01264-0.01271	70	0.01271-0.01274	30	100

Table 3: Rise time (t_r) and fall time (t_f) of identified pulses at 5kV of applied voltage in negative half cycle.

It is observed from the Table 2,3 that the PD pulses are having rise time, fall time and pulse width in the range of micro-second. The duration of the fall time is usually less than that of the rise time.

Variation of number of PDs with respect to phase angle:

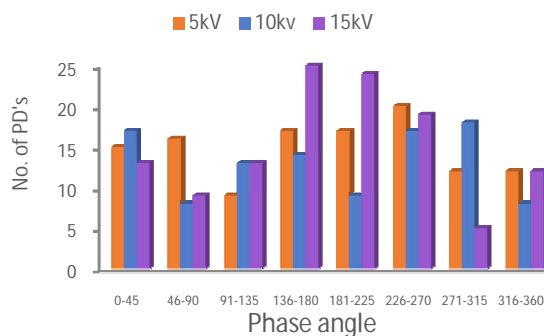

Fig 13: Partial discharge pulses at different phase angle with different applied voltages in cylindrical void(r=10mm and height=20mm)

The partial discharge pulses are analyzed by dividing single applied sinusoidal cycle of 50 Hz into eight equal parts. Each part has 45° phase angle interval. The number of PD pulses for each interval is plotted for different applied voltages. Figure 13 shows graph for number of PD pulses v/s different phase angle for different applied voltages (i.e, 5kV, 10kV and 15kV). The partial discharge phenomenon is random in nature so the numbers of PD pulses are not constant for every cycle [5].

Frequency content of obtained PD pulse:

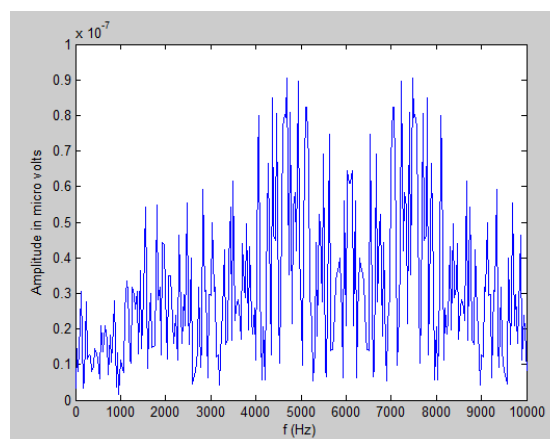

Fig 14: Frequency plot of observed PD pulse at 5 kV applied Voltage.

International Journal of Innovative Research in Science, Engineering and Technology

(An ISO 3297: 2007 Certified Organization)

Vol. 5, Issue 12, December 2016

Fast Fourier Transformation (FFT) is used to analyze the frequency content of the obtained PD pulse. The frequency plot of the observed PD pulse with applied voltage of 5 kV and dimension of the void is $r=10\text{mm}$, $h=20\text{mm}$ is shown in figure 14. PD phenomenon is random in nature. So, the frequency content of PD pulse is also fluctuating or random as the dimension of the void varies. It is also observed that the maximum amplitude of the frequency of the same PD pulse is appearing approximately around 4.5 kHz and 7.5 kHz which is shown in Fig.14. The dominant frequency of PD appeared because of the time duration of the PD pulses appears for such instance are much shorter compare to the other PD pulse instance present in the observed PD signal [3].

VI. CONCLUSION

Continuous monitoring of PD activity is essential to ensure the effective performance of the insulator. In this work, the effect of geometry of void present inside the insulation on the PD activity is analyzed. The variation of apparent charge transfer with variation in the dimensions (r , h and volume) of the void, PD amplitude with variation in the dimensions of the void is studied. When the radius of void from 1mm to 30mm with height being constant, the graph of apparent charge transfer with respect to radius and apparent charge transfer with respect to height from 1mm to 30mm with radius being constant is observed to be parabolic. As the radius of the void is increased beyond 30mm the curve is linear and the rate of charge transfer is higher. As the height of the void is increased beyond 30mm there is a rapid increase in charge transfer compared to the region where the height of the void is less than 30mm. The magnitude of internal discharges increases with increasing cavity dimensions. It is observed that the maximum amplitude of PD pulse increases in positive half cycle and decreases in negative half cycle as the dimension of the void varies. The PD activity depends upon the dimensions of the void. Rise time (t_r), fall time (t_f) and pulse width of the PD pulses are calculated. The PD pulses are having rise time, fall time and pulse width in the range of micro-second. The variation of number of PDs with respect to phase angle for different applied voltages is studied and it is random. The frequency content of PD pulse is analyzed and it is fluctuating as PD phenomenon is random in nature.

REFERENCES

- [1] E.Kuffel, W.S.Zaengl and J.Kuffel, High voltage Engineering: fundamentals, second ed., Elsevier, 2005
- [2] M.S.Naidu and V.Kamraju, High Voltage Engineering, New Delhi: Tata McGraw- Hill, 2004, pp.69-85.
- [3] S.Karmakar and A.Sabat, "International Journal on Electrical Engineering and Informatics," *Simulation of Partial Discharge in High Voltage Power Equipment*, vol.3, nov.2, 2011.
- [4] F.H.Kreuger, Partial Discharge Detection in High-Voltage Equipment, London, United Kingdom: Butterworths & Co Ltd, 1989.
- [5] C Sunil kumar, Dr. B. Ramachandra, "PD Analysis in Cubical Void With Respect to Geometry of the Void" International Journal of Innovative Research in Electrical, Electronics, Instrumentation And Control Engineering vol. 4, issue 10, October 2016.
- [6] R.Bartnikas, "Partial Discharge their mechanism, Detection and Measurement," *IEEE Trans. Electr. Insul.*, vol.9, pp. 763-808, 2002
- [7] C Sunil kumar, Dr. B. Ramachandra, Madhushree H N "Comparison of PD Activity in Cylindrical and Cubical Void using MATLAB Simulink" International Journal of Innovative Research in Electrical, Electronics, Instrumentation And Control Engineering vol. 4, issue 10, October 2016
- [8] C Sunil kumar, Harisha K S, Gouthami N, Harshitha V, Madhu C "Partial Discharge Analysis of a Solid Dielectric Using MATLAB Simulink" International Journal of Innovative Research in Electrical, Electronics, Instrumentation And Control Engineering vol. 4, issue 6, June 2016.
- [9] C. Smith, "Partial Discharge and Insulation failure," IPEC Ltd., 2005
- [10] J. J. Smit, E. Gulski, P. Bauer, P. Cichoki and J. Setyawan, *Investigation of Partial Discharge Occurrence and Detectability in High Voltage Power Cable Accessories*, Delft, 2009.
- [11] R. J. Van Brunt, "Physics and Chemistry of partial discharges and corona," *IEEE Trans. on dielectric and Electrical Insulation*, vol. 1, no. 5, pp. 761-784, 1994

BIOGRAPHY



C Sunil Kumar completed his Engg. from STJIT, Ranebennur and Masters from NIE Mysore, presently pursuing Ph.D. in University of Mysore, Mysore. Working as Asst. Professor in PESCE, Mandya from 2006.

International Journal of Innovative Research in Science, Engineering and Technology

(An ISO 3297: 2007 Certified Organization)

Vol. 5, Issue 12, December 2016



Dr. B. Ramachandra working as Professor and Head in E&E Engg., PESCE, Mandya, Karnataka, India. He had his Ph.D from IISc. Bangalore, Master's from IIT-Bombay. He has about 25 scientific publications in this area. He is also academic active, guiding research students and interacting with universities.



H C Manohara completed his Engg. from SJCE, Mysore and Masters from SJCE, Mysore, presently pursuing Ph.D. in University of Mysore, Mysore. Working has Asst. Professor in PESCE, Mandya from 2010.