

Performance Improvement in Transmission System using Controllable Network Transformer

Rasmina .K.K ¹, Reji. P²

P.G. Scholar, Department of Electrical & Electronics Engineering, Govt. Engineering College, Thrissur, Kerala, India¹

Associate Professor, Department of Electrical & Electronics Engineering, Govt. Engineering College, Thrissur, Kerala, India²

ABSTRACT: Power flow control through a transmission system is necessary under short circuit conditions and unbalanced conditions. Generally, Flexible AC Transmission System (FACTS) devices are used to control active and reactive power through a transmission system. But it has high cost and cannot be control active and reactive power simultaneously. In this paper a Controllable Network Transformer (CNT) is used that can control active and reactive power simultaneously and also for controlling power between two areas , thus increase the reliability of the system. It is a cost effective device , because it replaces the existing transformer. Dual Virtual Quadrature Source (DVQS) technique is used for controlling active and reactive power simultaneously. A Hybrid Active Filter (HAF) is used to mitigate these third harmonics. Simulations are done in MATLAB and results are verified for various values of active and reactive power.

KEYWORDS: Power system control, Flexible AC Transmission System (FACTS) devices, Controllable Network Transformer (CNT), Dual Virtual Quadrature Sources (DVQS), Hybrid Active Filter (HAF), coupling effect, closed loop controller.

I. INTRODUCTION

Increase in penetration of renewable energy and demand for electricity is the cause of congestion in the transmission system. Traditionally congestion is avoided by building more transmission lines. But it may very difficult in some areas . The main parameters of dynamic control of transmission lines are voltage and power flow. So dynamic control of power flow has become an important need for the transmission system. Flexible AC Transmission System (FACTS) devices are power control devices which increase the potential and capacity of the whole or overall system, without the need of building new transmission lines [1]. FACTS were developed based on power electronics to improve the performance of long distance AC transmission lines ,either by controlling the voltages or by modifying the impedance of the line .FACTS devices are mainly two types –impedance based and voltage source converter type. Impedance type FACTS devices include the shunt var compensator such as thyristor switched capacitor and thyristor controlled inductors [2]. These are not cost effective because of which need large energy storage inductors or capacitors to meet the power demand and do not have active power controllability. Moreover ,shunt connected reactors are used to minimize line over voltages under light loading conditions, while shunt capacitors are used to maintain voltage levels under heavy loading conditions. STATCOM is a voltage source converters (VSCs) type FACTS device which used to injects or absorb reactive power from the transmission system [3]. By varying the output voltage of the three phase inverter it is possible to control the reactive power absorbed or injected by the STATCOM. However, FACTS devices are high cost and it cannot be control active and reactive power simultaneously. Invention of power electronics switches like IGBTs ,MOSFETs etc are used in converters to increase the efficiency and reliability of the system. This paper proposed a cost effective dynamic power control device -Controllable Network Transformer (CNT)[4]-[6]. It consists of a load tap changer (LTC) transformer with a fractionally rated direct ac-ac converter to control both active and reactive power simultaneously. Switching of ac-ac converter is done by using a novel technique –Dual Virtual Quadrature Sources (DVQS) [7]. In open loop control of CNT using DVQS technique the output voltage

consists of unwanted third harmonics. To mitigate these unwanted third harmonics a series Hybrid Active Filter (HAF) is introduced. Also, there is a cross coupling effect between active and reactive power which can be eliminated by a decoupled closed loop control.

II. CONTROLLABLE NETWORK TRANSFORMER (CNT)

A Controllable Network Transformer is a centre tapped or load tap changing (LTC) transformer and a low rated ac-ac converter is connected to the secondary. The schematic of CNT is shown in Fig.1. The transformer has two taps (1+n) pu and (1-n) pu voltage levels, which connected to the converter switches S1 and S2 with duty cycle D and (1-D). A pair of Back to Back (BTB) insulated gate bipolar transistors (IGBT) are used for realising ac switches. For the protection of converter a thyristor pair is used to bypass the fault current.

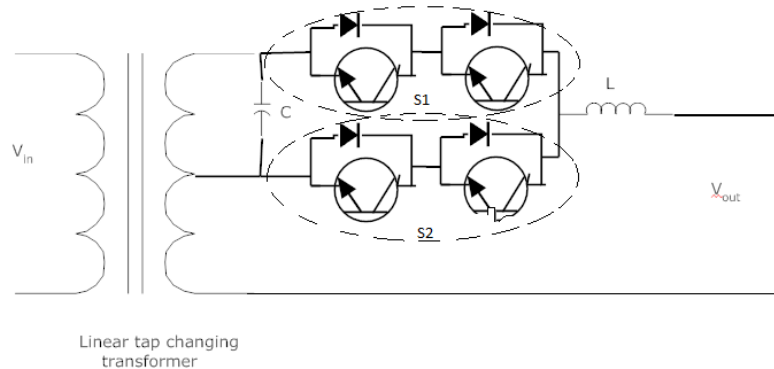

Fig.1 Schematic of CNT

For a fixed duty cycle, the output voltage magnitude of CNT can be controlled by using LTC. Voltage angle magnitude control can be achieved by using a new technique Dual Virtual Quadrature Sources (DVQS) technique. Using this technique, a CNT can achieve control over both real and reactive power.

(A) DUAL VIRTUAL QUADRATURE SOURCES (DVQS)

In this paper DVQS technique is used to control the AC-AC switches and corresponding voltage magnitude and phase angle control. It creates dual virtual quadrature sources that allow the synthesis of output voltages with controllable phase and harmonic levels without requiring the use of stored energy at the fundamental frequency. Using DVQS technique an even harmonics is introduced into the duty cycle of converter to control voltage phase angle. This can be realised by using even harmonic modulation (EHM). Here modulating signal consists of even harmonic components with a DC shift having duty cycle,

$$D = K_0 + K_2 \sin(2\omega t + \varphi) \quad (1)$$

Where K_0 is fundamental DC component, K_2 is magnitude of second harmonic component and φ is the desired output phase angle. Here K_0 , K_2 and φ are control variables. The value of K_0 can be varying between 0 and 1 and that of K_2 can be varying between -0.5 to +0.5. Also consider the below relation between K_0 and K_2 when selecting its values.

$$K_2 \leq \min(K_0, 1 - K_0) \quad (2)$$

The resulting output voltage consists of third harmonics in addition to the desired output. This harmonics can be eliminating using filters.

(B) PERFORMANCE OF CNT ON A TRANSMISSION SYSTEM

Fig.2 shows a transmission line connecting between two areas represented as two buses, bus i and bus j with voltages,

$$V_i = V_{in} = V_1 \sin(\omega t) \quad (3)$$

$$V_j = V_2 \sin(\omega t - \delta) \quad (4)$$

Using Dual Virtual Quadrature Sources technique ,duty cycle having even harmonic components is applied to the AC-AC converter switches and the resultant output voltage of CNT is given in Eqn.(5).

$$V_0 = V_1 (A \sin \omega t - B \cos(\omega t + \varphi)) + BV_1 \cos 3\omega t \tag{5}$$

where $A = \frac{1+n-2K_0n}{1-n^2}$ (6)

and $B = \frac{nK_2}{1-n^2}$ (7)

A and B are linearly related to control variables K_0 and K_2 respectively. Also real and reactive power flow through the transmission line is given in Eqn.(8) and Eqn.(9).

$$P_{line, cnt} = \frac{V_1 V_2}{\omega L} (A \sin \delta - B \cos(\delta + \varphi)) \tag{8}$$

$$Q_{line, cnt} = \frac{V_1}{\omega L} \left[(A^2 - \frac{2}{3} B^2) V_1 - AV_2 \cos \delta + BV_2 \sin(\delta + \varphi) \right] \tag{9}$$

Active and reactive power flowing through the transmission system with CNT can be written in matrix form as,

$$\begin{bmatrix} P_{line, cnt} \\ Q_{line, cnt} \end{bmatrix} = \begin{bmatrix} \frac{V_1 V_2}{\omega L} \sin \delta & \frac{-V_1 V_2}{\omega L} \cos(\delta + \varphi) \\ \frac{-V_1 V_2}{\omega L} \cos \delta & \frac{-V_1 V_2}{\omega L} \sin(\delta + \varphi) \end{bmatrix} * \begin{bmatrix} A \\ B \end{bmatrix} + \begin{bmatrix} 0 \\ \frac{V_2^2}{\omega L} \end{bmatrix} \tag{10}$$

From the equation , it is clear that real and reactive power flowing through the transmission line can be controlled by varying the control variables. That can be realised by changing the duty cycle of AC-AC converter.

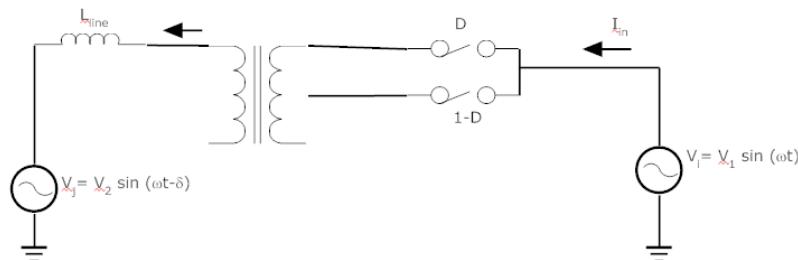

Fig.2 CNT connecting between two bus system

A two bus system with 138 kV is simulated with CNT having 30 mile length (0.79 ohms/mile) . The tapping of load tap changing transformer is +/- 20% (n=0.20) and the phase angle between the two buses is assumed to be 2 degree. The simulation model of CNT connecting between two buses is shown in Fig.3.

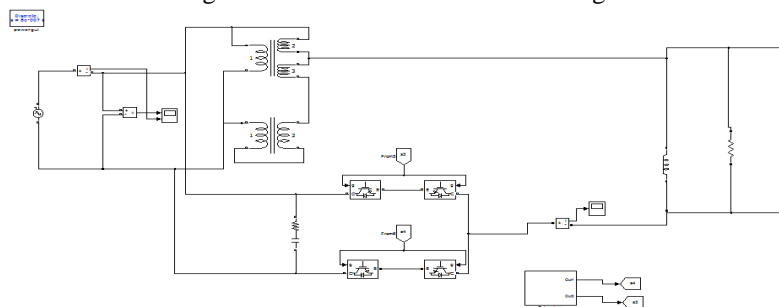

Fig.3 Simulation model of CNT connecting between two buses

The active and reactive power flowing through the system without any controller is 100 MW and 46 MVAR. When a CNT is connected between this two bus system, the active and reactive power can be varied upto +/-20 MW and +/-108 MVAR. This power variation can be achieved by varying the control variables K_0 , K_2 and φ . Bydirectional flow of current is possible by varying angle φ . From Eqn (5) it is found that the output voltage of CNT consists of unwanted third harmonics.

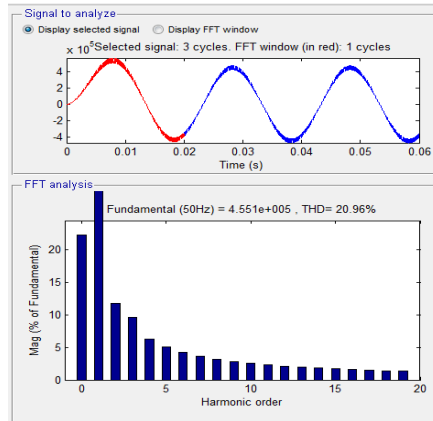

Fig.4 THD analysis of line current without filter

Fig.4 shows the THD analysis of line current with CNT having control variables $K_0 = 0.5$ and $K_2 = 0.4$. From the THD analysis the THD is 20.96 %.

(C) SERIES HYBRID ACTIVE FILTER

CNT output voltage with harmonics increases losses and reduce the efficiency of the system. Harmonics produced by CNT can be mitigated using filters. Filters are mainly two types, passive and active filters. Passive filters use passive elements such as inductors ,capasitors etc. Passive L-C trap can be a simple solution to the third harmonic problem. Here third harmonics present in the CNT output voltage can be reduced upto 16% using passive filter, so its performance is very limited.

In this paper a series hybrid active filter is used for mitigating third harmonics produced by CNT using DVQS technique.

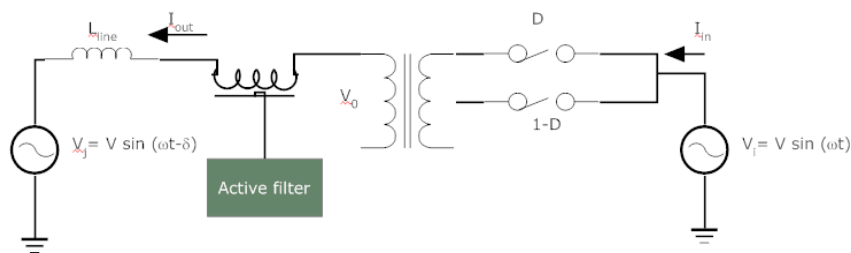

Fig.5 CNT with series hybrid active filter

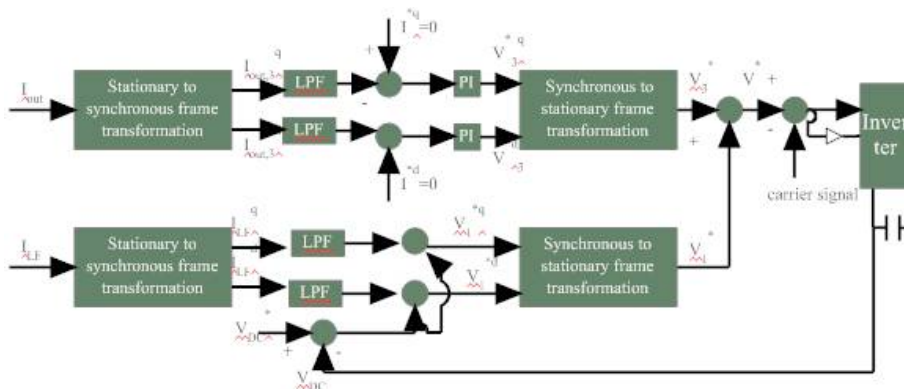

Fig.6 Block diagram of series HAF control

Using series hybrid active filter, harmonics are reduced upto 4.6%. DVQS technique has two disadvantages, one is which produces third harmonics shown in Fig 4. Use of hybrid active filter increases size of the system and it is not economical. Second disadvantage is the control variables defined in this technique have a cross coupling effect between active and reactive power shown in Fig(8). It means that independent active and reactive power control is not possible in open loop control. So a decoupled closed loop controller is designed to achieve independent active and reactive power control based on a reference power control command.

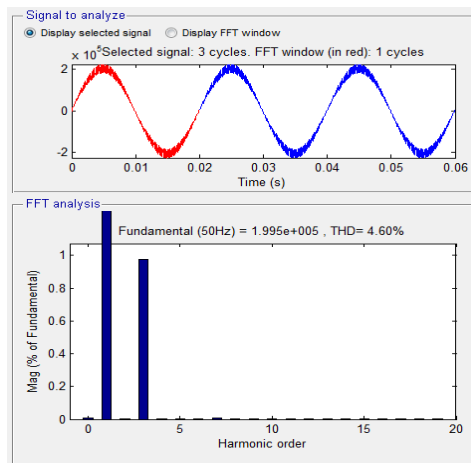
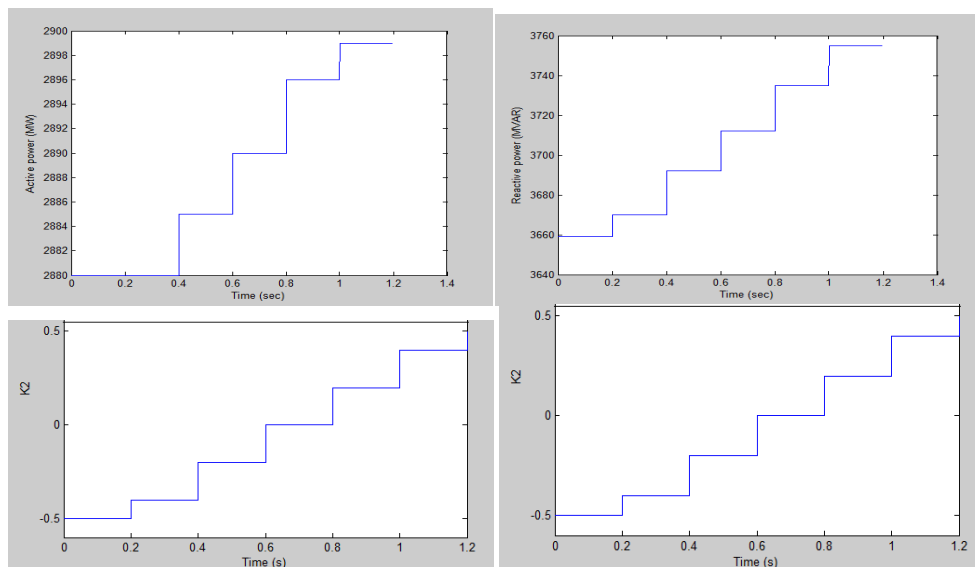

Fig.7 THD analysis of line current with series HAF filter

Fig.7 shows the THD analysis of line current with CNT-HAF system having control variables $K_0 = 0.5$ and $K_2 = 0.4$. It is observed that THD is 4.60 %. Fig.8 shows the graph of variation of active and reactive power by varying K_2 from -0.5 to +0.5. Consider an operating point of control variables $K_2=0.2$ and $K_0=0$ the corresponding active and reactive power are 2880 MW and 3670 MVAR respectively. If control variable K_2 is increased to 0.4 active and reactive power changed to 2885 MW and 3692 MVAR. It means that variation of control variables cause changes in both active and reactive power. So it is not possible to change active and reactive power independently.



(a)

(b)

Fig.8 Simulation results of changing active and reactive power with variation of K_2 while $K_0 = 0$

(D) DECOUPLED CLOSED LOOP CONTROLLER

If any change in variables A and B in open loop control of CNT results change in both active and reactive power. Decoupled closed loop controller is developed to achieve independent active and reactive power control is shown in Fig (9). The duty cycle is generated by comparing the line powers (both active and reactive) with the reference powers (P* and Q*). The control of active and reactive power can be achieved by changing the reference active (P*) and reactive power (Q*). PI and PLL controller are present in the closed loop controller, which help to independent active and reactive power control.

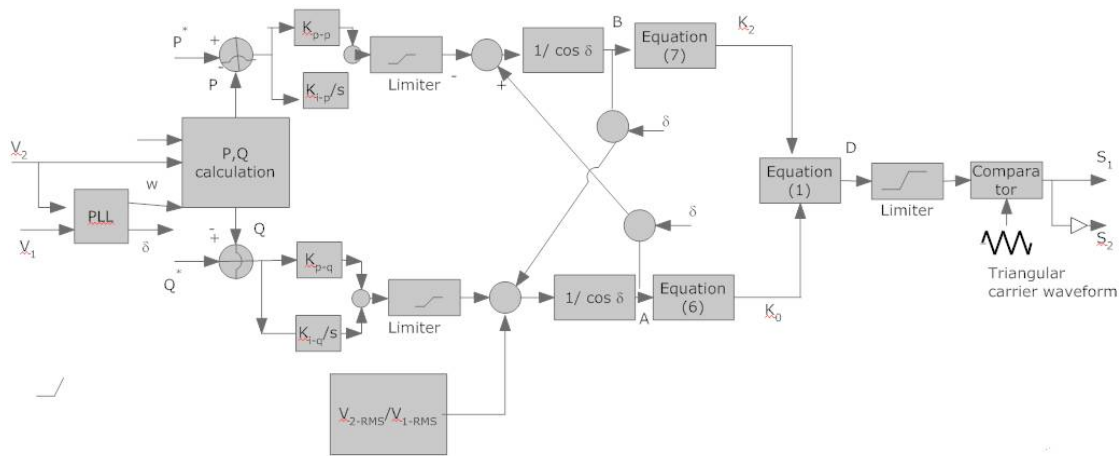

Fig.9 Block diagram of decoupled closed loop controller.

In this control algorithm a PI controller is defined in Eqn.(11) and Eqn.(12) can be used to control active and reactive power.

$$(K_{P-P} + \frac{K_{I-P}}{s}) (P^*_{line,cnt} - P_{line,cnt}) = A \sin \delta - B \cos \delta \tag{11}$$

$$(K_{P-Q} + \frac{K_{I-Q}}{s}) (Q^*_{line,cnt} - Q_{line,cnt}) = \frac{V_2}{V_1} - A \cos \delta - B \sin \delta \tag{12}$$

$$B = \frac{1}{\cos \delta} (A \sin \delta - P_{line,cnt} \frac{\omega L}{V_1 V_2}) \tag{13}$$

$$A = \frac{1}{\cos \delta} (\frac{V_2}{V_1} - B \sin \delta - Q_{line,cnt} \frac{\omega L}{V_1 V_2}) \tag{14}$$

Substituting equations (11),(12),(13) and (14) in (10) gets active and reactive power as

$$\begin{bmatrix} P_{line,cnt} \\ Q_{line,cnt} \end{bmatrix} = \frac{V_1 V_2}{\omega L} \left\{ \begin{bmatrix} K_{P-P} + \frac{K_{I-P}}{s} & 0 \\ 0 & K_{P-Q} + \frac{K_{I-Q}}{s} \end{bmatrix} * \begin{bmatrix} P^*_{line,cnt} \\ Q^*_{line,cnt} \end{bmatrix} + \begin{bmatrix} K_{P-P} + \frac{K_{I-P}}{s} & 0 \\ 0 & - (K_{P-Q} + \frac{K_{I-Q}}{s}) \end{bmatrix} * \begin{bmatrix} P_{line,cnt} \\ Q_{line,cnt} \end{bmatrix} \right\} \tag{15}$$

The above matrices are diagonal which means that defined PI controller successfully allowing independent control over active and reactive power. The PLL errors will generate a wrong network angle which initially introduces decoupling effect. But in the final stage it disappears and not effect active and reactive power as seen in Eqn(15). Since PI and decoupling loop can automatically compensate these errors. Other calculation errors will not impact the decoupling process .

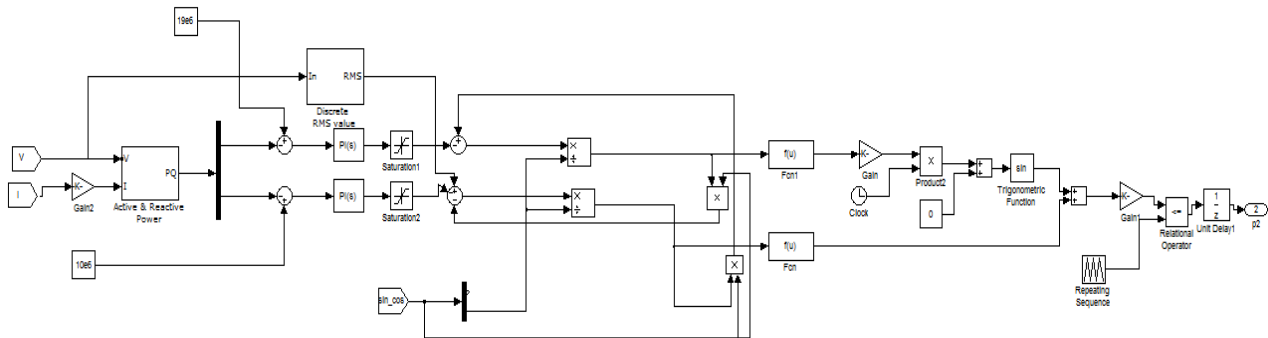

Fig.10 Simulation model of closed loop controller

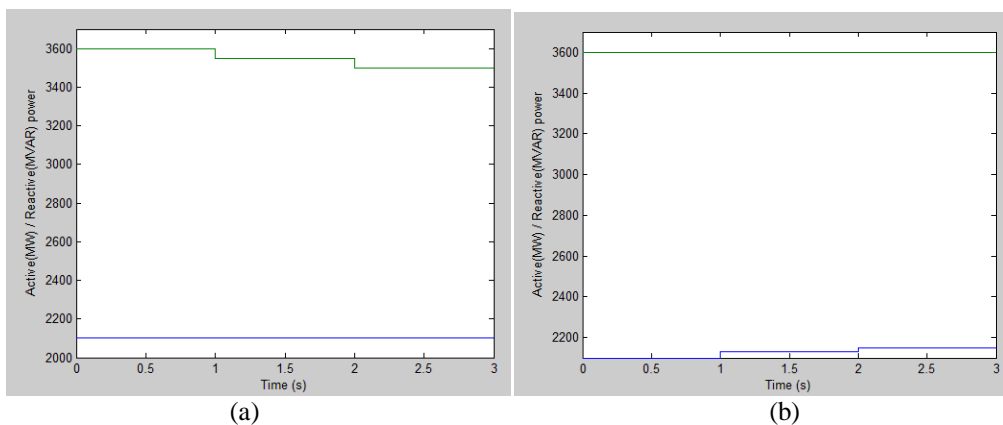

Fig.11 Simulation results of changing active and reactive power. (a) Varying reactive power with constant active power=2100 MW. (b) Varying active power with constant reactive power=3600 MVAR.

Fig.11 shows independent control of active and reactive power. Fig(11a) shows that changes of reactive power command from 3600 Mvar to 3550 Mvar and then to 3500 Mvar with constant active power command. Fig (11b) shows that changes of active power command from 2100MW to 2130 MW and then to 2150 MW with constant reactive power command. It means that active and reactive power can be changed independently by changing either active or reactive power command.

IV. CONCLUSION

CNT is a cost effective power flow control device used to control both active and reactive power simultaneously. For that the magnitude and phase angle of line voltage can be changed by using DVQS technique. This paper simulated open loop and closed loop control of CNT using DVQS technique to control power flow through transmission line. Open loop control is not economical because it consists of a series hybrid active filter which increases size and cost of the system. Also variation in control variables defined by DVQS technique shows decoupled effect between active and reactive power. It means that varying any control variable causes variation of both active and reactive power. These problems can be solved using decoupled closed loop controller, which defined a PI controller to control active and reactive power simultaneously. A 138kV transmission line with CNT is simulated and the results were verified.

REFERENCES

- [1] H. Ren et al .,"A review of FACTS practical consideration and economic evaluation" .in Proc. Asia-Pacific Power Energy Eng.Conf.,2009,pp.1-5.
- [2]] F. Iliceto, E. Cinieri, "Comparative analysis of series and shunt compensation schemes for AC transmission systems", IEEE Transactions on Power Apparatus and Systems, Volume: 96 , Issue: 6 , Publication Year: 1977 , Page(s): 1819 – 1830

International Journal of Innovative Research in Science, Engineering and Technology

An ISO 3297: 2007 Certified Organization

Volume 5, Special Issue 5, April 2016

International Conference on Emerging Trends in Smart Grid Technology - INCETS'16

Organized by

Dept. of EEE, College of Engineering, Trikaripur (CAPE, Government of Kerala), Cheemeni, Kasaragod, Kerala-671313, India

- [3] P. Petitclair, Y. Besanger, S. Bacha, N. Hadjsaid, "FACTS modelling and control: applications to the insertion of a STATCOM on power system", IEEE Industry Applications Conference, 1997, Volume: 3, Publication Year: 1997, Page(s): 2213 – 2217
- [4]] Dubrup Das, Rajendra Prasad Kandula, Javier A. Munoz, Deepak Divan, Ronald G. Harley and Joe E. Schatz, "An Integrated Controllable Network Transformer-Hybrid Active Filter System", IEEE Trans. Ind. Appl., vol. 51, no. 2 March? April 2015.
- [5] D. Divan and J. Sastry, "Controllable network transformers," in *Proc. IEEE PESC, Jun. 15–19, 2008, pp. 2340–2345*.
- [6] D. Das and D. Divan, "Power flow control in networks using controllable network transformers," in *Proc. IEEE Energy Convers. Congr. Expo.*, 2009, pp. 2224–2231.
- [7] D. Divan and J. Sastry, "Voltage synthesis using dual virtual quadrature sources—A new concept in AC power conversion," in *Proc. IEEE PESC, Jun. 2007, pp. 2678–2684*.
- [8] Hao Chen, Amrit R. Iyer, Ronald G. Harley, Divan, "Dynamic grid power routing using Controllable Network Transformer with Decoupled Closed-Loop Controller", IEEE Trans. Ind. Appl., vol. 51, no. 3 May/June 2015.