

Three-Phase Four-Switch Inverter-Fed Induction Motor Drives with DC-Link Voltages Offset Suppression & Torque Control

Abila Vijay¹, Vasuda K V²

P.G. Student, Department of Electrical & Electronics Engineering, Vidya Academy of Science & Technology, Thrissur, Kerala, India¹

Assistant Professor, Department of Electrical & Electronics Engineering, Vidya Academy of Science & Technology, Thrissur, Kerala, India²

ABSTRACT: This paper investigates the performance of a 4-switch, 3-phase inverter (B4) fed cost effective induction motor (IM) drive system with dc link voltages offset suppression & torque control. The voltage vectors of the B4 inverter under the fluctuation of the two dc-link capacitor voltages are derived for precise control of the torque and stator flux. The balanced three-phase currents are achieved and the capacitor voltage offset is suppressed in the introduced scheme. The different control schemes are PWM techniques and direct torque control method. In the introduced approach, instead of a conventional 6-switch, 3-phase inverter (B6) a 4-switch, 3-phase inverter is utilized [1]. This reduces the cost of the inverter, the switching losses, and the complexity of the control algorithms and interface circuits to generate 6PWM logic signals. The Simulation results of the introduced B4 inverter fed drive is also made in terms of reduction of speed & torque ripple, balanced the capacitor voltage & balanced the stator 3 phase current. The introduced inverter fed IM drive is found acceptable considering its cost reduction and other advantageous features.

KEYWORDS: B4- Four Switch Three Phase Inverter, IM-Induction Motor, PWM- Pulse Width Modulation, THD- Total Harmonic Distortion. 3-phase inverter

I. INTRODUCTION

The use of power converters has become very popular in the recent decades for a wide range of applications, including drives, energy conversion, traction, and distributed generation. The control of power converters has been widely studied, and new control schemes are presented every year. The conventional three-phase voltage- source inverter with six switches (B6) has been found widespread industrial applications in various forms, such as motor drives and active filters. However, in certain applications, a further cost reduction for inverter configuration is considered by users. To achieve this goal, the three-phase inverter with only four switches was introduced for the purpose of minimizing the components cost, and it is named four-switch three-phase (B4) inverter. Although this kind of cost reduction is at the expense of output performance, the B4 inverter can be utilized in fault-tolerant control to solve the open/short-circuit fault of the B6 inverter. The idea of the B4 inverter applied to fault-tolerant control is very valuable in some critical occasions such as rail traction, and it has consequently attracted the interest of many researchers.

The work in this paper is divided in two stages. 1) Balance the capacitor voltages 2) Balancing the stator current 3) torque control with different load torque 4) reduced the torque ripple 5) reduce switching losses and switching stress. Paper is organized as follows. Section I describes introduction, Section II describes the drive system and control approach of B4 inverter fed induction motor drive system. It also describes the details of B4 inverter and modelling of induction motor. Section III describes the simulation and results and Section IV presents conclusion.

II. THE DRIVE SYSTEM AND CONTROL APPROACH

The block diagram of the introduced system is shown in Fig 1. The drive system consists of a 3 phase ac supply, 3 phase Diode bridge Rectifier, 3 phase four switch Inverter, 3-phase Induction Motor and controlled circuits. The standard ac power supply is converted to a dc by using a 3-phase diode bridge rectifier. A voltage source B4 inverter is used to convert the dc voltage to the controlled ac voltage. The output of B4 inverter is fed to 3- phase induction motor. Then generate the controlled PWM pulses at different duty ratio for B4 inverter to drive the Induction Motor at different speeds.

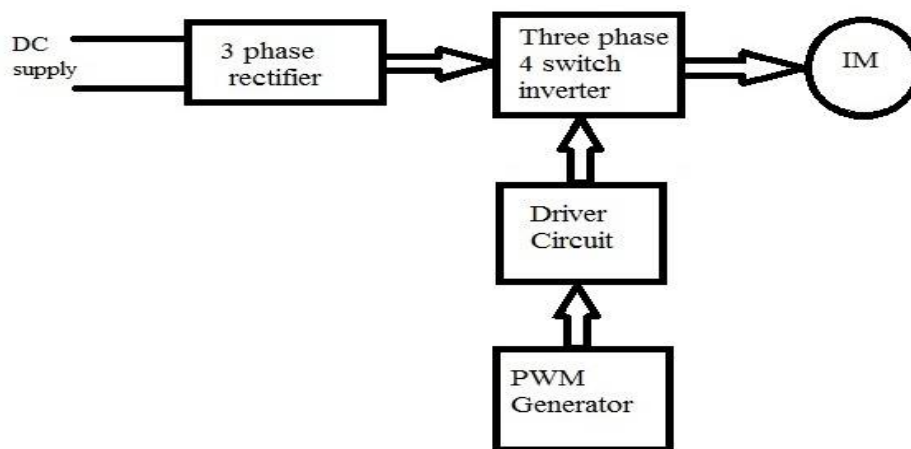

Fig 1: Block Diagram Of 3 Phase 4 Switch 3 Phase Inverter Fed Induction Motor Drive

III. 4 SWITCH 3 PHASE INVERTER FED INDUCTION MOTOR DRIVE

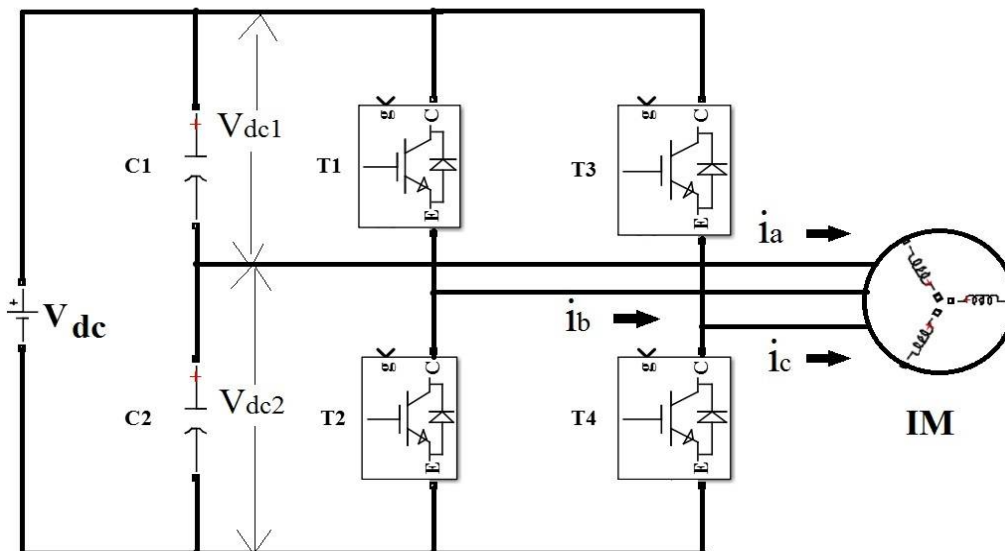

Fig 2: 4 switch 3 phase inverter fed induction motor drive

1. Intrinsic Voltage Vector of A B4 Inverter

The power circuit of the IM fed from 4 switch 3 phase voltage-source inverter is shown in Fig.3. The circuit consists of two parts; first part is a front-end rectifier powered from single-phase supply. The output dc voltage is smoothed through a two series connected capacitors. The second part of the power circuit is the three-phase four-switch inverter.

The maximum obtainable peak value of the line voltages equals V_{dc} , in the analysis, the inverter switches are considered as IGBT. The output voltages are defined by the gating signals of the two leg switches and by the two dc link voltages, V_{dc} .

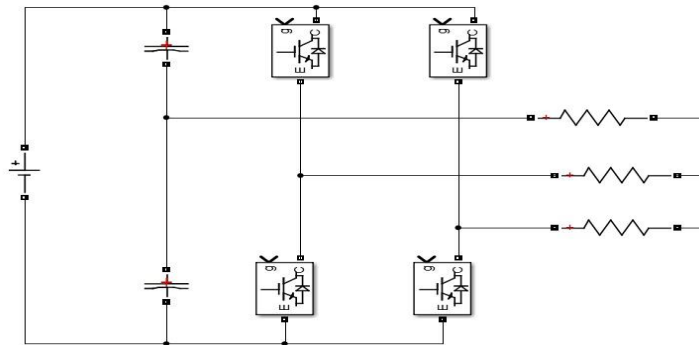

Fig 3: 4 switch 3 phase inverter

The B4 topology consists of a two-leg inverter, as illustrated. The dc-link is split into two voltage sources, to the middle of which one load phase is connected. For convenient analysis, the inverter is considered for implementation by ideal switches (T1 to T4) (i.e., with no dead time and no saturation voltage drop). This means, the switching states of leg b (T1 & T2) and leg c (T3 & T4) can be denoted as binary state variables S_b and S_c . To prevent the short circuit of the dc-link, the simultaneous closed states of two switches in each leg are usually forbidden. Therefore, a binary 1 will indicate the close state of the upper switch, whereas a binary 0 will indicate the close state of the lower switch. The basic voltage vectors can be defined according to the switching states. Assume that the three-phase voltages are balanced, the phase- to-neutral voltages V_{aN}, V_{bN}, V_{cN} are given as follows[2]:

$$\begin{aligned} V_{aN} &= V_{dc1}/3 (-S_b - S_c) + V_{dc2}/3 (2 - S_b - S_c) \\ V_{bN} &= V_{dc1}/3 (2 \cdot S_b - S_c) + V_{dc2}/3 (2 \cdot S_b - S_c - 1) \\ V_{cN} &= V_{dc1}/3 (2 \cdot S_c - S_b) + V_{dc2}/3 (2 \cdot S_c - S_b - 1) \end{aligned}$$

Where V_{dc1} and V_{dc2} are the upper and the lower dc-link capacitor voltages, respectively. Considering all the possible combinations of (S_b, S_c), phase- to-neutral voltages values are given in Table I. The Clarke transform applied to the stator voltages yields as follows:

$$\begin{bmatrix} V_{\alpha s} \\ V_{\beta s} \end{bmatrix} = \frac{2}{3} \begin{bmatrix} 1 & -\frac{1}{2} & -\frac{1}{2} \\ 0 & \frac{\sqrt{3}}{2} & -\frac{\sqrt{3}}{2} \end{bmatrix} \begin{bmatrix} V_{aN} \\ V_{bN} \\ V_{cN} \end{bmatrix}$$

Where the $V_{\alpha s}$ and $V_{\beta s}$ are the α - and β -axis stator voltage, respectively. The voltage vectors are expressed by $\vec{v}_s = V\alpha + j V\beta$

TABLE I: SWITCHING FUNCTION AND THE OUTPUT VOLTAGES OF THE B4 INVERTER

States		Switches ON		Output Voltage		
Sa	Sb			V_{aN}	V_{bN}	V_{cN}
0	0	T2	T4	$2V_{dc2}/3$	$-V_{dc2}/3$	$-V_{dc2}/3$
0	1	T2	T3	$V_{dc2} - V_{dc1}/3$	$-2V_{dc2} - V_{dc1}/3$	$V_{dc2} + 2V_{dc1}/3$
1	0	T1	T3	$V_{dc2} - V_{dc1}/3$	$V_{dc2} + 2V_{dc1}/3$	$-2V_{dc2} - V_{dc1}/3$
1	1	T1	T4	$-2V_{dc1}/3$	$-V_{dc1}/3$	$V_{dc1}/3$

Therefore, the four active voltage vectors (V1 to V4) in the $\alpha\beta$ plane are given in Table II [3]. It is clearly revealed that in Table I, the B4 inverter can only produce four basic nonzero voltage vectors. The basic voltage vectors change in amplitude and angle in case of dc-link voltage are not equal. If the values of the upper and lower capacitance are big enough to keep the capacitor voltages a constant value of $V_{dc}/2$, the four voltage vectors produced by the four

kinds of switching combination are presented in Fig 4(a). Otherwise, a ripple in the two capacitor voltages leads to a deviation of these vectors from the previous positions. The vector positions are presented in Fig 4(b) and 4(c) in the situation of $V_{dc1} < V_{dc2}$ and $V_{dc1} > V_{dc2}$, respectively.

TABLE II: BASIC VOLTAGE VECTORS OF THE B4 INVERTER

Switching states		Voltage Vectors	Vector Symbol
Sa	Sb		
0	0	$2V_{dc2}/3$	V1
1	0	$(V_{dc2} - V_{dc1})/3 - j\sqrt{3}(V_{dc2} + V_{dc1})/3$	V2
1	1	$V_{dc2} - V_{dc1})/3 + j\sqrt{3}(V_{dc2} + V_{dc1})/3$	V3
0	1	$-V_{dc1}/3$	V4

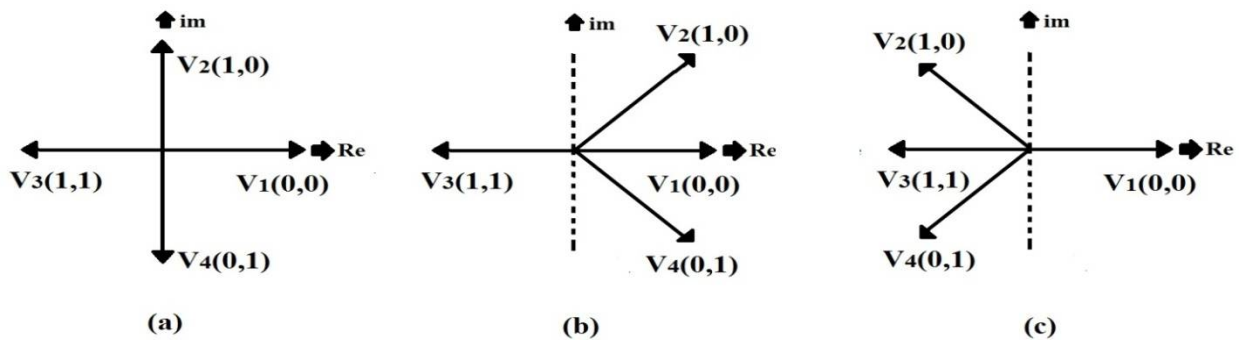

Fig.4. Basic Voltage Vectors Of The B4 Inverter In The Case of : (A) $V_{dc1} = V_{dc2}$, (B) $V_{dc1} < V_{dc2}$, And (C) $V_{dc1} > V_{dc2}$.

2. Induction Motor Modelling

Stator variables, voltage \vec{v}_s , current \vec{i}_s , and flux $\vec{\psi}_s$ are electrically related according to

$$\vec{v}_s = R_s \vec{i}_s + \frac{d\vec{\phi}_s}{dt}$$

Where R_s is the stator resistance.

Rotor equation in a stator reference frame represents the relation between rotor current \vec{i}_r and rotor flux $\vec{\psi}_r$ as follows:

$$0 = R_r \vec{i}_r + \frac{d\vec{\phi}_r}{dt} - j\omega \vec{\psi}_r$$

where R_r is the rotor resistance and ω is the rotor speed. Flux linkage equations relate stator and rotor currents are given in (3.5) and (3.6), where L_m , L_s , and L_r are the mutual, stator, and rotor inductances, respectively

$$\vec{\psi}_s = L_s \vec{i}_s + L_m \vec{i}_r$$

$$\vec{\psi}_r = L_m \vec{i}_s + L_r \vec{i}_r$$

Electromagnetic torque T_e can be expressed in terms of stator current and stator flux

$$T_e = \frac{3}{2} p * \vec{\phi}_s * \vec{i}_s$$

where p is the number of pole pairs. The ratio of change in the mechanical rotor speed ω by the torque

$$J \frac{d\omega}{dt} = T_e - T_L$$

where the coefficient J denotes the moment of inertia of the mechanical shaft, and T_L is the load torque to the machine. ω_m is the mechanical rotor speed and it is related to the electric rotor speed ω by the number of pole pairs p :

$$\omega = p * \omega_m$$

IV. SIMULATION WORK AND RESULTS

Digital computer simulation model of B4 inverter fed induction motor drive has been developed by using SIMULINK MATLAB. The simulation work has been performed for balancing the capacitor voltage and stator currents. This drive system simulated at different load conditions. This reduced the torque ripple.

This B4 inverter fed drive system consists of a three-phase diode bridge rectifier, a split capacitor, four switch three phase inverter and 3- phase squirrel cage Induction Motor.

- Input supply voltage: 3-phase, 415 V (rms), 50 Hz
- Input capacitor : 2040uF
- Induction Motor: 2.2 KW 400 V, 50 Hz, 1500 rpm.
 - Stator resistance $R_s = 1.405 \Omega$
 - Rotor resistance $R_r = 1.395 \Omega$
 - Stator inductance $L_s = 0.005839 \text{ H}$
 - Rotor inductance $L_r = 0.005839 \text{ H}$
 - Mutual inductance $L_m = 0.3489 \text{ H}$
 - Pole pairs = 2
 - Moment of inertia $J = 0.15 \text{ J}$
 - Frictional factor $B = 0.00098 \text{ F}$

The complete simulink block diagram of system is shown in Fig 5. Simulink model contains 3 phase voltage source has given to 3 phase diode rectifier. It rectify the ac voltage into dc voltage and given to the 3 phase 4 switch inverter. The dc voltage has been equally divided by the two capacitor C1 & C2. Output of B4 inverter has given to 3 phase squirrel cage induction motor. Switching pulses generates the PWM pulses for 4- switches of B4 inverter at the terminals s1 to s4 [5]. The capacitor voltage balanced by controlling the switching pulses. The balanced 3-phase output currents of B4 inverter i_a , i_b and i_c with IM are shown in Fig 6(e). The output line voltage waveform V_{ab} , V_{bc} and V_{ca} of B4 inverter is shown in Fig 6(d). The speed and torque characteristics of induction motor with load are shown in fig 6(a) and 6(b). Balanced capacitor voltage also shown in fig 6(c). It is observed that the speed increases linearly and reaches the rated speed at steady state in 10 sec. At starting the torque increases and reduces to a minimum value when the speed reaches the rated value. When the torque reaches its maximum value there is only 0.5% ripple was presented [6].

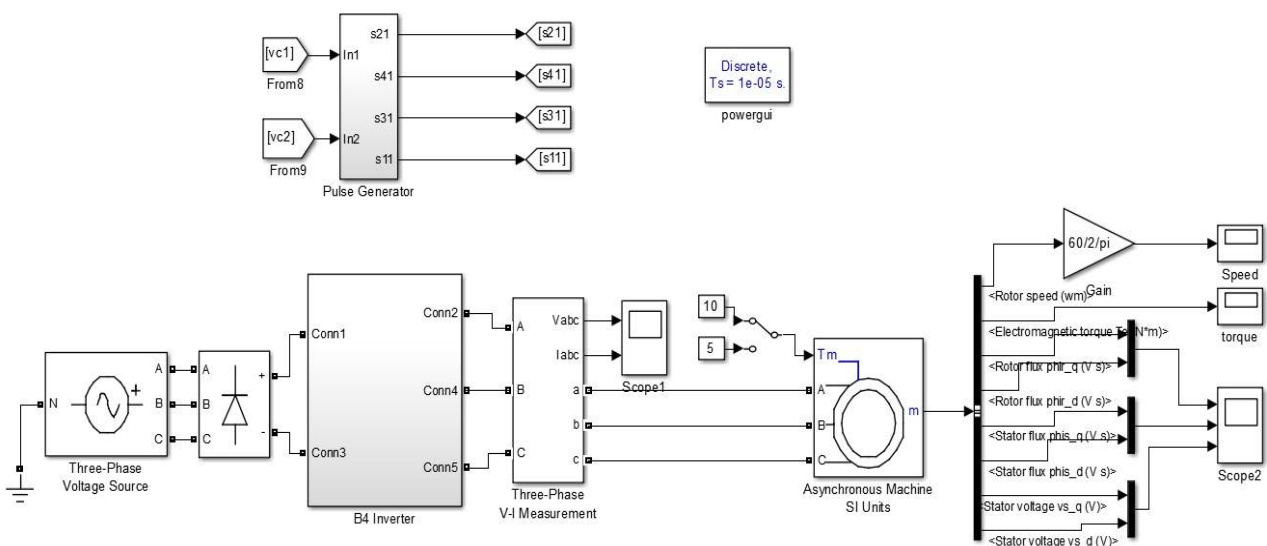
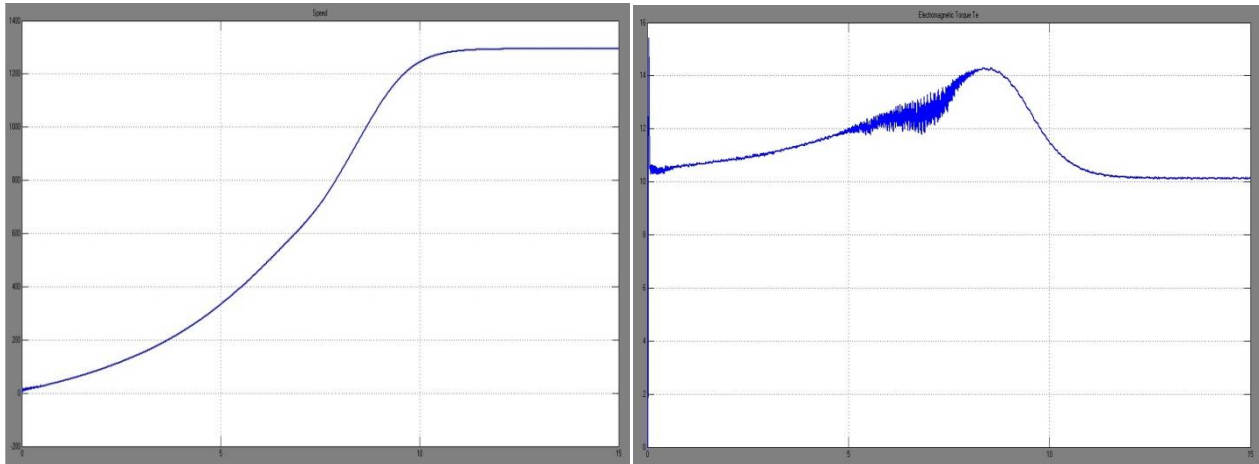
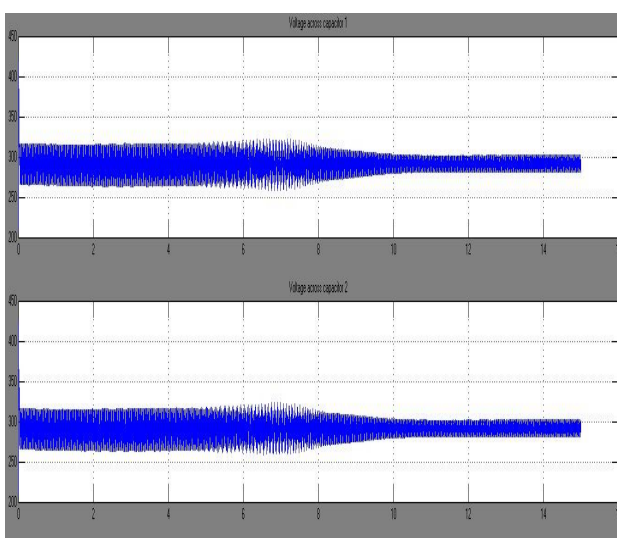

Fig 5 : Simulink model of B4 fed Induction motor drive



(a) Speed = 1300 rpm

(b) $T_e = 10 \text{ N m}$



(c) $V_{c1} \text{ \& } V_{c2} = 300 \text{ V}$

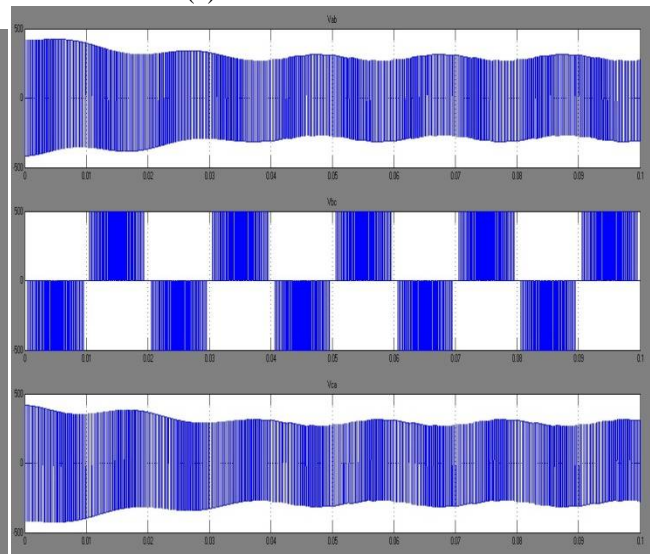

(d)

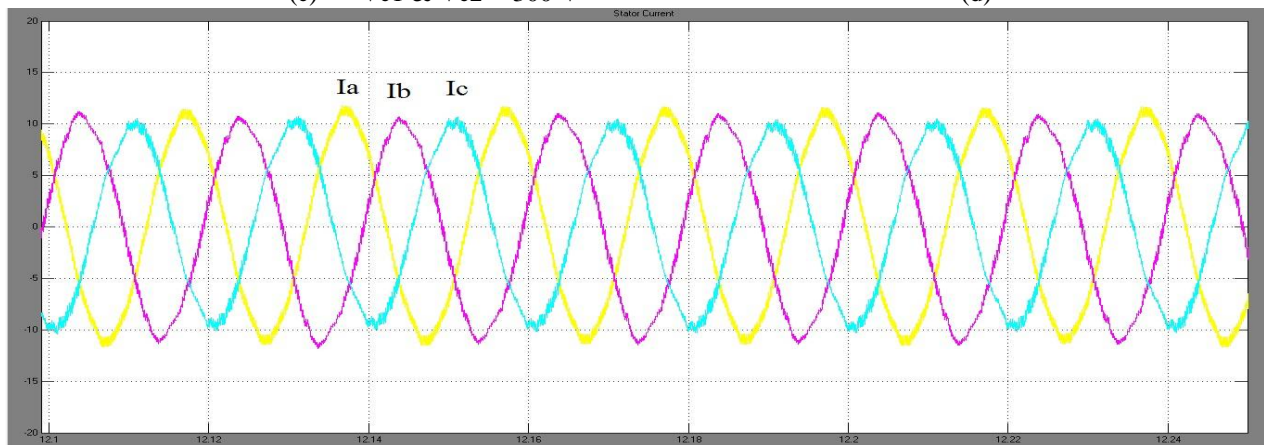

(e)

Fig 6: Simulated waveforms using the introduced scheme in a B4 inverter- fed IM: (a) speed (b) electromagnetic torque (c) Capacitor voltages (d) line voltages V_{ab} , V_{bc} & V_{ca} (e) stator currents I_a , I_b & I_c

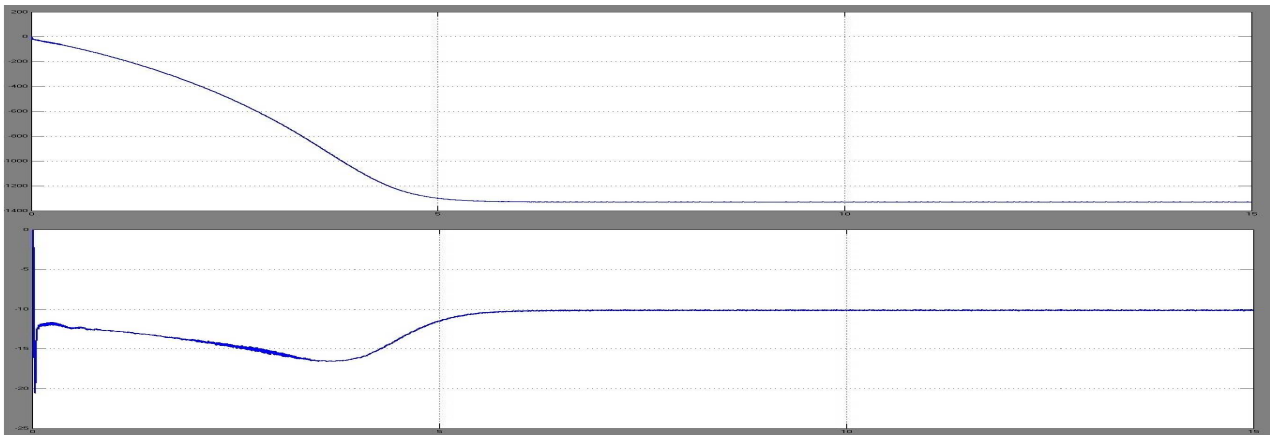

Fig 7: Simulated waveforms using the introduced scheme in a B4 inverter- fed IM: Torque & speed behaviours during a speed-reversal

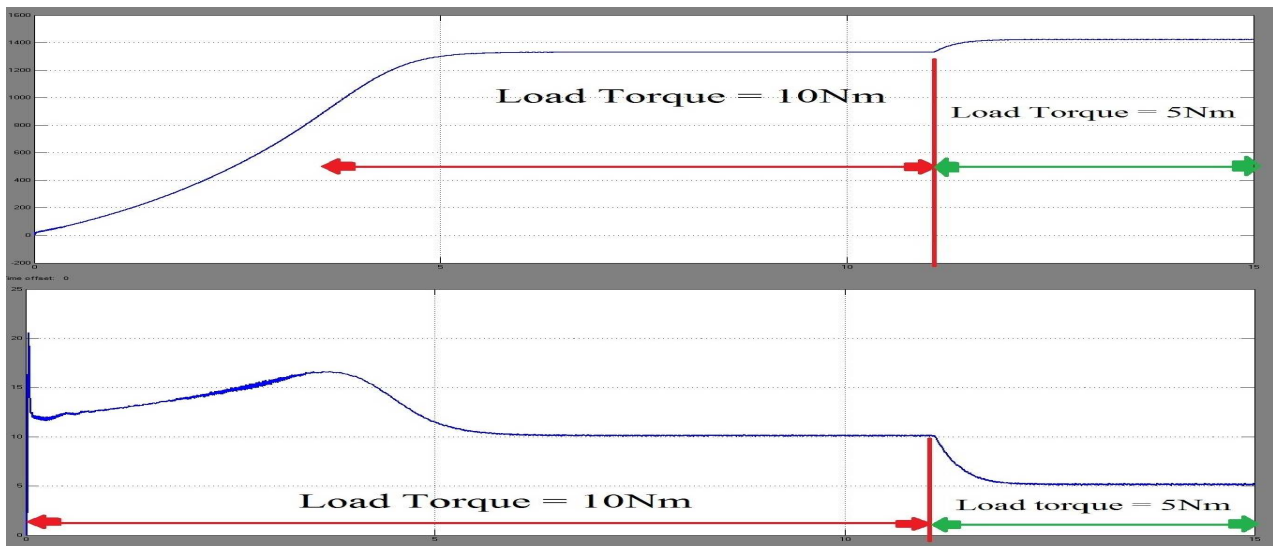

Fig 8: Simulated waveforms using the introduced scheme in a B4 inverter- fed IM: Torque & speed behaviours during different load torque ($T_L = 10\text{Nm}$ & 5Nm)

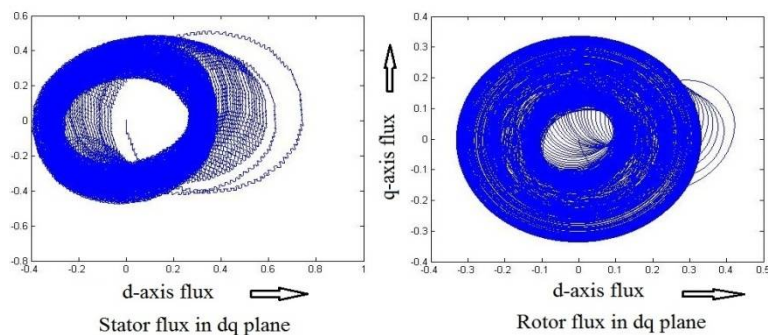

Fig 9: Simulated waveforms using the introduced scheme in a B4 inverter- fed IM: Stator & rotor flux locus described in dq plane

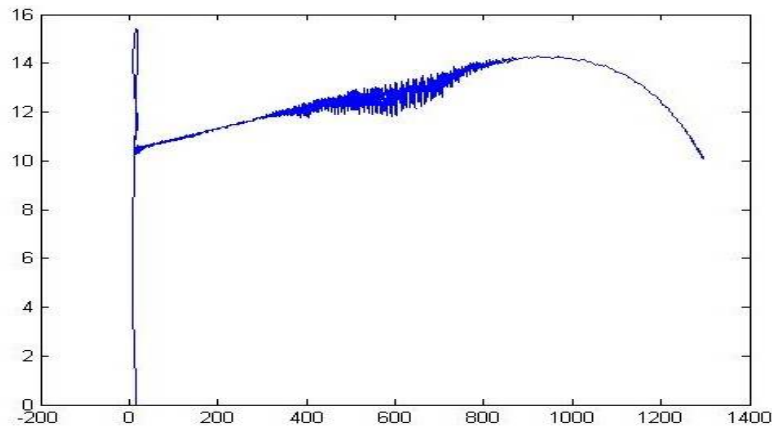

Fig 10: Torque- speed characteristics

V. CONCLUSION

In this paper, the B4 inverter-fed IM drives are analysed and successfully simulated. The voltage vectors of the B4 inverter under the fluctuation of the two dc-link capacitor voltages are derived and control of the torque and stator flux. The balanced three-phase currents are achieved and the capacitor voltage offset is suppressed by using this scheme. The torque ripple was reduced to 0.5% only. The theory and performance evaluation of the introduced scheme for the B4 inverter-fed IM drive are investigated. The introduced B4 inverter-fed IM drive has been found acceptable for high performance industrial variable-speed-drive applications considering its cost reduction and other inherent advantageous features.

REFERENCES

- [1] H. W. Van der Broeck and J. D. Van Wyk, "A comparative investigation of a three-phase induction machine drive with a component minimized voltage-fed inverter under different control options," *IEEE Trans. Ind. Appl.*, vol. IA-20, no. 2, pp. 309–320, Mar. 1984.
- [2] M Dehong Zhou, Jin Zhao, and Yang Liu, "Predictive Torque Control Scheme for Three-Phase Four-Switch Inverter-Fed Induction Motor Drives With dc-Link Voltages Offset Suppression" *IEEE Transactions On Power Electronics*, Vol. 30, No. 6,
- [3] Arpit S. Bhugull, Dr. Archana G. Thosar, "Simulation of Direct Torque Control of Induction motor using Space Vector Modulation Methodology .", *International Journal Of Modern Engineering Research (IJMER)*
- [4] B.El Badsı, B. Bouzidi , and A. Masmoudi, "DTC scheme for a four-switch inverter-fed induction motor emulating the six-switch inverter operation," *IEEE Trans.Power Electron.*, vol. 28, no. 7, pp. 35283538, Jul. 2013.
- [5] Ashwini Kadam,A.N.Shaikh "Simulation & Implementation Of Three Phase Induction Motor On Single Phase By Using PWM Techniques" *International Journal of Engineering Research and General Science* Volume 2, Issue 6, October-November, 2014 ISSN 2091-2730
- [6] Prof. A.A.Apte, V.D.Malwade "Simulation Of A 4-Switch,3-Phase Inverter Fed Induction Motor (IM) Drive System" *INTERNATIONAL JOURNAL OF INNOVATIONS IN ENGINEERING RESEARCH AND TECHNOLOGY [IJIERT]*