

# Congestion Management by Determination of ATC Using Power Word Simulator 14

Ganesh B.Murade<sup>1</sup>, Ashok Kumar Jhala<sup>2</sup><sup>1</sup>P.G. Student, Department of Electrical & Electronics Engg., RKDF College of Engg., Bhopal, M.P, India<sup>2</sup>Asso. Professor, Department of Electrical & Electronics Engg., RKDF College Of Engg , Bhopal , M.P, India

**ABSTRACT:** In deregulated market, the various challenges are comes to way but the major problem in the electrical market is congestion management of the physical transmission network. In this paper the congestion management has been discussed & minimize the same by the calculation of Available Transfer capability by changing the GPF. Information of ATC of the transmission network will give the strategy for congestion less network, this computation minimizes the risk in the network and sensitivity of the network will be maintained. This paper proposes the evaluation of ATC by using PTDF & participation factor. This calculation is made by conventional method & by power world simulator 14.

**KEYWORDS:** Network congestion, GPF, Available transfer capability, Power transfer distribution factor.

## I. INTRODUCTION

Introduction In power system restructuring, creating competitive market is the main objective. In the deregulated power system framework has been changing the conventional vertical integrated structure [1]. Depending upon the policies, sellers generating companies may supply the power to buyers (loads) under various conditions like optimal, bilateral transaction or fixed participation. Due to all these condition, one or more component of network may beyond their limits, so that it causes congestion and further forbidding the security of the transmission network. Transmission network component has to be determined before permitting the power transaction. ATC is evaluate of network capability unspent in the network for promote commercial process all over. Transmission network transfer capability is limited by a number of different mechanisms, including thermal, voltage, and stability constraints [2] by knowing the value of ATC; we can obtain the congestion free network for market operation. [4]. the predefined participation of generator has to fulfil the load demand that required in real time. So ATC outcomes must calculated the changes in load by various generators inspite of single bilateral transaction. [5] This paper describes the theory of generator participation factor.

The methods ATC calculation gives the prospect of change in load participation factor. The total change in load is split into various bilateral transactions with the help of participation factor. [7][8]. GPF examines the active power output of the generator changes and it is also responsible for demand while generator available for AGC & control of GPF. The impact of counting GPF is observed on ATC. The time computation of ATC is reduce by changes in line flow of power flow analysis. The load changes value is needed for preparing a data and this value is determine ATC With consideration of GPF.

## II. RELATED WORK

There are different methods suggested by various researchers, for calculation and improvement of ATC. The paper proposes the evaluation of ATC by using PTDF & participation factor. This calculation is made by conventional method & with the help of power world simulator 14. The proposed work is carried out on 11 bus power system. By selecting various generator participation factors and the algorithm based on NRM, its impact on network congestion is observed. The results are verified by evaluating ATC using Power World Simulator 14.

# International Journal of Innovative Research in Science, Engineering and Technology

(A High Impact Factor, Monthly Peer Reviewed Journal)

Vol. 5, Issue 1, Januray 2016

In restructured power system the policies are flexible, so the load bus could require being more than one generator. This paper proposed that by variation in participation factors, it is maximum load allowed at bus which provides network support without causing the insecurity. This proposed work is carried out on a 11-bus power systems, designed in Power World Simulator 14. Load at a specified bus is continuously increased, till it leads to congestion in one or more transmission lines of network. It is observed that as generator participation factor changes, maximum allowable load at that bus changes. So we can calculate the ATC of the network and can manage the congestion in the network.

### III.CALCULATION OF ATC

ATC is a evaluate of network capability unspent in the transmission network for promote commercial process all over already fixed uses “The capability term here concern to the power transfer ability of lines(s) from one area to another by bus with reliability”.

$$ATC = TTC - TRM - \{CBM + ETC\} \quad (1)$$

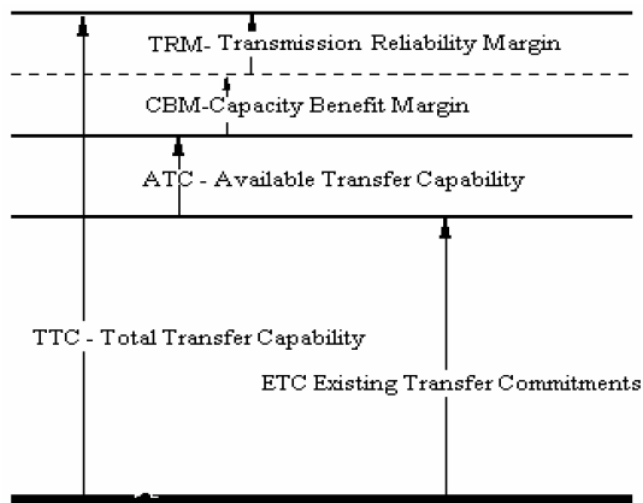

Fig-1: Graphical Demonstration

It is different from transfer capacity in means of that capacity implies specified line(s) rating and that accounts only for thermal limit. The other side line capability of other elements in the transmission network. Mathematically, ATC is defined as,

### Power Transfer Distribution Factor (PTDF)

In Computation of ATC a generator & a load are considered transaction wise .Direction of flowing active power is generator to load. For each way, the ATC value is the maximum MW generator injections that can be transmit to the load without spoiling any operating limits such as Line voltage limits, thermal limits and system stability limits. With respect to enquire how long the system is insecure condition and how can active power transaction affects the loading of the transmission system. It is essential to examine the sensitivities of line flows with regards to bus injections. These sensitivities are termed as PTDF.

# International Journal of Innovative Research in Science, Engineering and Technology

(A High Impact Factor, Monthly Peer Reviewed Journal)

Vol. 5, Issue 1, Januray 2016

PTDF bringing close together flow direction of transmission lines and change in response to between user interface and user is nothing but seller and buyer. For multipartite ATC, the transaction will be between two areas. & its depends on PTDF operating point.

## GENERATOR PARTICIPATION FACTOR

GPF is examining the active power output of the generator changes. And it is also responsible for demand while generator available for AGC and control of GPF. GPF is the ratio of power change of that generator to the change in load of same generator. It is given as,

$$x_i = \frac{\Delta T_{ik}}{\Delta P_k} \quad (2)$$

Where

$x_i$  = GPF ,

$\Delta T_{ik}$  = change in generator power at  $i^{th}$  bus due to change in load at  $k^{th}$  bus,

$\Delta P_k$  = Change in load at  $k^{th}$  bus.

To calculate the ATC, generating companies & consumer transaction are to be mentioned. This may be areas, injection groups, slack bus, a single bus etc. For assignment to exist a transaction of multi generators the areas, injection groups and GPF are require. The load flow solution is required for computing the GPF.

## CALCULATION OF ATC

Computation of ATC individual transaction is considered and changes are obtained in line flow. The transaction is obtained separately for PTDF & ATC by using NRM. PTDF is the one dimensional relationship between the amount of the flow on a line and a transaction. The change in line flow associated with a new transaction is then,

$$\Delta P_{ij}^{New} = PTDF_{ij,mn} P_{mn}^{New} \quad (3)$$

Where

i and j = buses at the receiving end of line being specified,

$P_{mn}^{New}$  = is new transaction in MW

m and n = "from" and "to" zone numbers for the suggested new transaction,

$$P_{mn,ij}^{Max} \leq \frac{P_{ij}^{Max} - P_{ij}^0}{PTDF_{ij,mn}} \quad (4)$$

$P_{mn,ij}^{Max}$  = the maximum allowable transaction amount from zone m to zone n.

ATC of the transmission network is restrained by the minimum transaction permit to overall lines.

$$ATC_{mn} = \min_{ij} P_{mn,ij}^{Max} \quad (5)$$

After ATC calculations, network congestion can be avoided in case of known ATC, a proper methodology can be applied to improve it. ATC being calculated by vary the GPF.

## International Journal of Innovative Research in Science, Engineering and Technology

(A High Impact Factor, Monthly Peer Reviewed Journal)

Vol. 5, Issue 1, Januray 2016

### IV. EXPERIMENTAL RESULTS

#### Case study

Outcomes of change of GPF on ATC of transmission network has been evaluated on 11 bus system as shown in fig-2

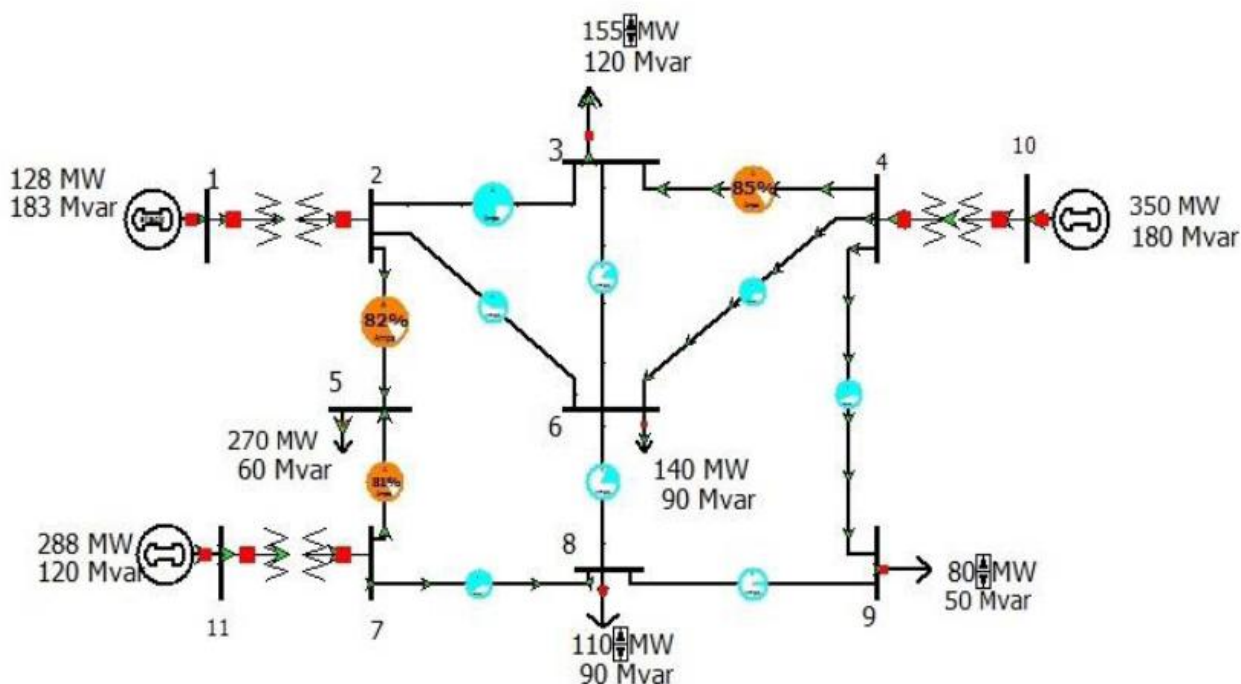

Fig 2 Eleven bus power system

The above fig 2 shows the 11 bus power system in which bus 1, bus 10 and bus 11 are generator buses and bus 3, bus 4 where as bus 5, bus 6, bus 8 and bus 9 are load buses. by change in load at bus 3, 8 & 9 the transfer capability has been computed from that ATC is evaluated which has been summed up in the Table 1.

#### Algorithm

1. GPF are set
2. base case such as, bus voltage, bus angle, power flows and current flow are computed
3. A variation in active power at a load bus is applied and power flow analysis using Power World Simulator 14 is computed.
4. The line PTDF and ATC for each transaction has been calculated.
5. Individual TC has been calculated for each transaction after that ATC of the network is calculated.
6. The next transaction is applied and the steps 3, 4 and 5 are repeated.

The PWS 14 Simulation software is designed for ATC computation. The consideration of bus load changes GPF and ATC is set and computed linearly.

## International Journal of Innovative Research in Science, Engineering and Technology

(A High Impact Factor, Monthly Peer Reviewed Journal)

**Vol. 5, Issue 1, Januray 2016**

Table-1: Available transfer capability, considering various generator participation factor and changes in load at bus 11

Sr. No	Applied Change in Load at bus 5 (MW)	Generator and Load Bus Pair	Transacting power MW x1=0.4 x2=0.3 x3=0.3	N/W ATC when Individual Transactions are of concern (MW)	N/W ATC (MW) for Simultaneous Power Transaction from all Generators to Bus 5
1	5	1---5	2		337.85
		10---5	1.5		
		11---5	1.5	113.35	
2	10	1---5	4		296.23
		10---5	3		
		11---5	3	88.86	
3	15	1---5	6		245.08
		10---5	4.5		
		11---5	4.5	73.52	
4	20	1---5	8		151.75
		10---5	6		
		11---5	6	45.52	
5	25	1---5	10		118.611
		10---5	7.5		
		11---5	7.5	35.58	
6	30	1---5	12		96.65
		10---5	9		
		11---5	9	28.99	
7	35	1---5	14		72.67
		10---5	10.5		
		11---5	10.5	21.8	
8	40	1---5	16		53.94
		10---5	12		
		11---5	12	16.18	
9	45	1---5	18		38.72
		10---5	13.5		
		11---5	13.5	11.61	

Congestion management is a major issue in deregulated power system .In this paper by using ATC calculation can used to provide information about capability of the network with change in GPF which gives congestion free network and hence can be used as a tool for congestion management. In order to prove the proposed statement a 11 –bus power system is designed in Power World Simulator 14..

## International Journal of Innovative Research in Science, Engineering and Technology

(A High Impact Factor, Monthly Peer Reviewed Journal)

Vol. 5, Issue 1, Januray 2016

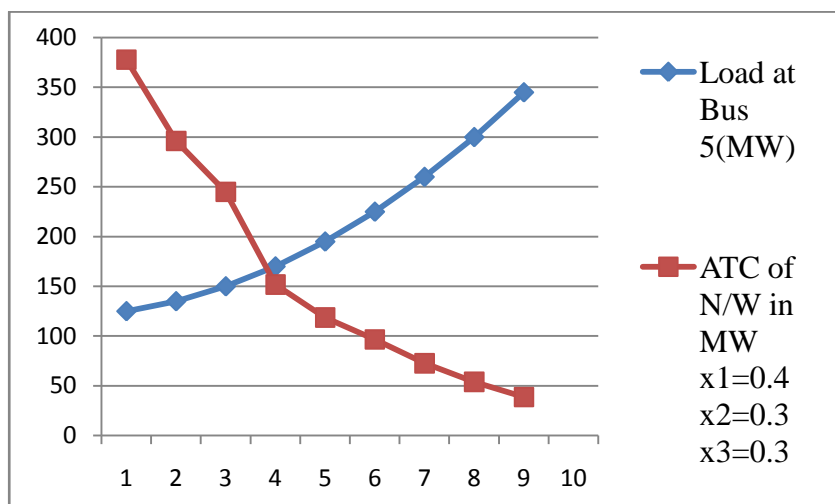

Fig.3 ATC & Load Variation

The 11-bus system has three generator buses and five load buses. In order to obtain the congestion point, load at a specified bus is increased. In this system load at bus-3 is continuously increased in steps of 5 MW till congestion point is reached.

The mitigation point shows the congestion in the network.

### V. CONCLUSION

The ATC values are determined by NRM. It is observed from table I that as the load increases, transacting power through various branches of network changes leading to decrease ATC of the network. From fig 3, it can be observed that the point of mitigation of the load curve and the ATC curve shows the congestion point. The network will be free from congestion as long as ATC curve is above the load curve at that bus. Change in load is shared by different generators depending upon their participation factor. Congestion management is a major issue in deregulated electrical market to remove congestion in case of known ATC, a proper strategy for its improvement must be applied. Here a new approach for; ATC computation by changing the participation factor is being evaluated.

### REFERENCES

- [1] M.Shahidehpour and M.Almouh "Restructured Electric Power System" Marcel-Deccer Publisher pp 158-169
- [2] Peter W. Sauer "Technical Challenges of Computing Available Transfer Capability (ATC)"
- [3] Bialek J. "Tracing the Flow of Electricity" IEE Proceedings of Generation Transmission and Distribution, Vol.143 No.4, pp.313-320. July 1996
- [4] Christie R.D, et al "Transmission Management in the Deregulated Environment" Proceedings of The IEEE, Vol. 88, No. 2, February 2000
- [5] S.C Srivastava et al "Available Transfer Capability (ATC) Determination in a Competitive Electricity Market Using AC Distribution Factors" Electric Power Components and Systems, Volume Issue 2, pages 927 - 939 2004
- [6] Costa, et al "Asment generator impact on system power transfer capability using modal partidpation factors", IEE Proc.. Goler. Trmm Dirtrib. 2002.
- [7] N.D Ghawghawe, K.L.Thakre K.L, "Determination of the Impact of Load Variations on Generator Participations". Power System Technology and IEEE Power India Conference, 2008.
- [8] N.D Ghawghawe, K.L.Thakre, "ATC evaluation with consideration of load changes and participation factors- A sensitivity analysis approach" Power Engineering Conference, 2007. IPEC 2007.
- [9] Z Huang, et al "Generator ranking using modal analysis" Generation, Transmission and Distribution, IEE Proceedings\_Volume: 150 Issue: 6 2004
- [10] I Kopcak, et al "Transmission systems congestion management by using modal participation factors" Power Tech Conference Proceedings, 2003 IEEE Bologna .
- [11] B.V Manikandan, at el' Multi-Area Available Transfer Capability Determination in the Restructured Electricity Market '978-1-4244-1762-9/08 IEEE C2008