

# International Journal of Innovative Research in Science, Engineering and Technology

(An ISO 3297: 2007 Certified Organization)

Vol. 5, Issue 6, June 2016

## Survey on Vehicular Automation

Chetana R. Markad<sup>1</sup>, N. A. Dawande<sup>2</sup>

P.G. Student, Department of E & TC Engineering, Dr. D.Y.Patil COE, Ambi, Pune, Maharashtra, India<sup>1</sup>

Associate Professor, Department of E & TC Engineering, . D.Y.Patil COE, Ambi, Pune, Maharashtra , India<sup>2</sup>

**ABSTRACT:** Transportation systems are a very important part of human activities. Estimation shows that an average of 40% of the population spends minimum one hour on the road each day. In recent years people have become much more dependent on transportation systems, the transportation systems themselves face not only several opportunities but several challenges as well. The competitiveness of a country, its economic strength and productivity heavily depend on the performance of its transportation systems. Intelligent Transportation Systems (ITS) have attracted increasing attention in recent years due to their great efforts in getting this above mentioned challenges. Advanced Vehicle Control System (AVCS) is a part of an ITS. The goal of AVCS is to improve the throughput as well as safety of highway traffic by using automatic control with its precision and quick reaction to replace human drivers. Ultimately, in a more futuristic goal, AVCS might enable an auto-piloted vehicles for taking passengers to their destinations without human driver intervention.

**KEYWORDS:** Advanced Vehicle Control System (AVCS), Automated Vehicle.

### I. INTRODUCTION

Automated vehicle navigation has been a dream for human for a long time. From past decade has seen path breaking developments in the field of automation. An autonomous vehicle is fundamentally defined as a vehicle that drives by itself. Various prototypes that have been built so far performed automatic steering which is based on sensing the painted lines on the road or magnetic monorails embedded in the road. Now a day researchers are using sensors with advanced software together with the custom made hardware in order to assemble autonomous vehicle. The prototypes seem to be very successful and fully autonomous vehicle that is reliable on the streets also not been commercialized yet, because of the difficulties in controlling a vehicle in the huge traffic conditions of urban areas.

Automated Vehicle systems are systems in which driving tasks of driver are taken by using an automated system. The reported benefits of AV (Automated Vehicle) systems involve improvements of the road traffic performance, safety enhancements and increased driver and passenger comfort. The road traffic performance improvements mainly follow from the possible shorter distance in time and space between two vehicles with AV capabilities.

### II. PREVIOUS METHODOLOGY

In New York control at the 1939 world's Fairs GM presented a vision of "driverless" vehicles moved under automated condition. In 1950s, industrial organizations research conceptualized automated vehicles which are controlled by mechanical systems and radio controls. After that in 1960s when the first appearance of computers takes place then researches began to consider potential uses of computers for providing lateral and longitudinal control and traffic management. Initially a fully automated highway concept was examined by GM with U.S sponsorship. In the late 1970s Department of Transportation (DOT), Advances in computing technologies, sensors and microelectronics in the 1980s proved commercial interest in technologies which enhances driver capability and perception.

In 1977 the first known worthy attempt to build an autonomous vehicle and this project research was carried out Laboratory in Japan by Tsukuba Mechanical Engineering . The car functioned by white street markers and was able to reach speeds up to 20 mph on dedicated test duration. During the 1990s DARPA Challenge the basic capability for car automation systems which was demonstrated in Europe, Japan and the U.S. respectively by the PROMETHEUS program, Advanced Cruise Assist Highway System Research Association and Automated Highway System (AHS). ISTEA (Inter-modal Surface Transportation Efficiency Act) enhances perception of partial

# International Journal of Innovative Research in Science, Engineering and Technology

(An ISO 3297: 2007 Certified Organization)

Vol. 5, Issue 6, June 2016

automation. ISTEIA, in 1991 were focused on the development of prototype and testing of fully automated vehicles and highways. U.S NAHSC (National Automated Highway System Consortium) was considering the nine major categories, in 1994. Again in 1994, the NAHSC was created for building the first working Automated Highway Systems.

Very limited literature is available which was based on the cost-benefit analysis of AVL systems applications in transit agencies. One reason for this could be that it is a relatively new technology also there is little data available for detailed cost-benefit analysis. In 1998, Gomez, Zhao and Shen cite the example of six transit agencies in their research paper and highlight the different service configurations, objectives, and other requirements that would determine the cost of an AVL system. Their survey of transit agencies using AVL and those in the implementation stage shows the three most important factors in opting for AVL technology that are improving schedule adherence, emergency response and also providing real-time travel information.

Recently Google's self-driving cars have been developed and Google announced that technology is only four to five years away from being road worthy. In 2014 the Volvo was developed which allow drivers to select an autonomous mode which keep pace with the cars ahead of the driver up to 31mph, also follow the bends in the street, and avoids obstacles without any human input. National Highway Traffic Safety Administration (NHTSA) begun a study on how best to regulate an autonomous cars. Currently only Nevada and California have laws on the books regarding a self-driving cars also those are simply allow them for testing purposes. NHTSA announce guidelines regarding the software and obstacle detection systems to autonomous vehicles, after few years of research.

Intelligent Transportation System provides an opportunity to apply advanced developed technology to systems and methods of transport for efficient, comfortable, and safer highways. The survey work focuses on the area of road transport, and more specifically, on field of intelligent vehicles. The vehicles are equipped with the help of instrumentation and the intelligence necessary to perform the required task. Since an autonomous vehicle must control some or all of its functions without external intervention. There are many challenges in conducting the full-scale ITS research when vehicles are involved. For example modifying the conventional vehicles into autonomous vehicles is usually costly in terms of money as well as time. Basically testing in real traffic environments is dangerous. Like this challenges have posed significant obstacles to many researchers in ITS and forced them to use pure computer simulation, in which it is extremely hard to mimic certain aspects like communication, vehicle dynamics.

Detecting and localizing lanes from a road image is an important factor of many intelligent transportation system applications. The active research on lane detection and tracking and modalities (stereo or monocular) have been proposed. Due to real time constraints, the lane markings have been detected based only on simple gradient changes. Various commercial lane detection systems are available and also show the good performance in many challenging road and illumination conditions.

### III. ADVANCED VEHICULAR CONTROL SYSTEM

AVCS represent the application by using sensors, computers, and electromechanical actuators for providing drivers with warnings of hazards, controlling the vehicles, or fully automated control of vehicle motions. The main purposes of these systems are to increase safety and to decrease congestions on roads and highways, also to improve road systems productivity. AVCS also includes advancement in cruise control, automated steering control for lane keeping and autonomous behavior, like automated stopping vehicle and lane changes in reaction to other vehicles.

#### A. Benefits of AVCS

The AVCS technologies have the potential to increase the capacity of a bridge or freeway by several hundred percent. By taking the driving function over from the driver, these technologies can also eliminate the driver error caused accidents.

### IV. PREVIOUSLY IMPLEMENTED SYSTEM

The main goal of the design is to distribute the control over the CAN bus. Initial design for an autonomous ATV is as shown in the Fig. 1.

In the design (Fig. 2), for interfacing devices to the microcontroller many I/O ports are used, which increases interconnections and makes the hardware look like clumsy. Instead of that in [5] can replace all the interconnections with the help of a single two wire CAN bus. Fig. 2 show the proposed design with the CAN bus.

# International Journal of Innovative Research in Science, Engineering and Technology

(An ISO 3297: 2007 Certified Organization)

Vol. 5, Issue 6, June 2016

The RX62N microcontroller and few other devices connected to it by using CAN bus shown in the block diagram. The two pins from the RX62N, CANL and CANH which create a bus for communication. The microcontroller used the h-bridge satisfy the purpose of generating signals to the h-bridge in correspondence with the data received from CAN bus. Throttle servo and radio receiver are directly connected to the RX62N. The PC sends data on to the CAN bus, signaling the ATV (All-Terrain Vehicle) to steer in the corresponding direction Fig. 1. Design without CAN bus Fig. 2. Design with the CAN bus which was based upon the data from the GPS, LIDAR, and Camera. For the communication of data from PC to RX62N A RS232-CAN module or a USB-CAN module can be used.

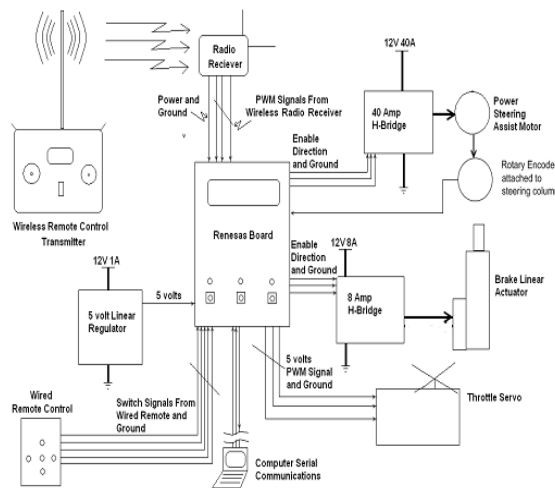

Fig 1: Design without CAN bus

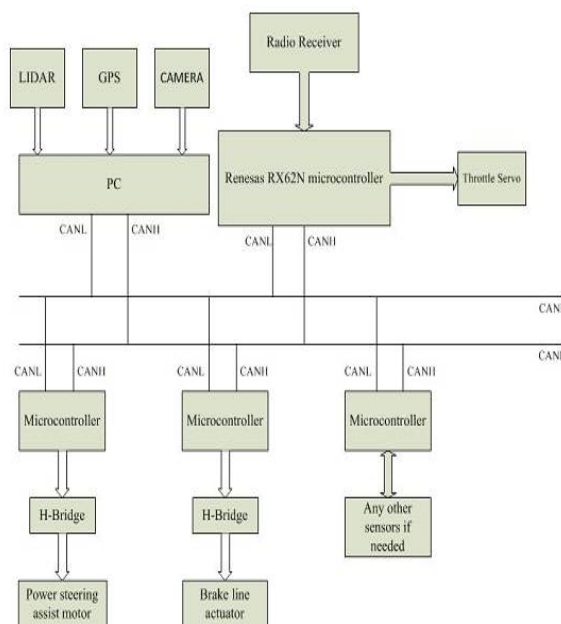

Fig 2: Design with the CAN bus

## International Journal of Innovative Research in Science, Engineering and Technology

(An ISO 3297: 2007 Certified Organization)

Vol. 5, Issue 6, June 2016

The advantages of implementing the CAN bus over ATV would be

1. Decreased wire harnesses
2. Easy installation of devices on to the bus
3. Error detection and fault confinement
4. Does not affect the operation of the bus if any node breaks down
5. Real time performance
6. Robust to noisy environments

The fig 3 show the proposed system block diagram and fig 4 show the tracking section.

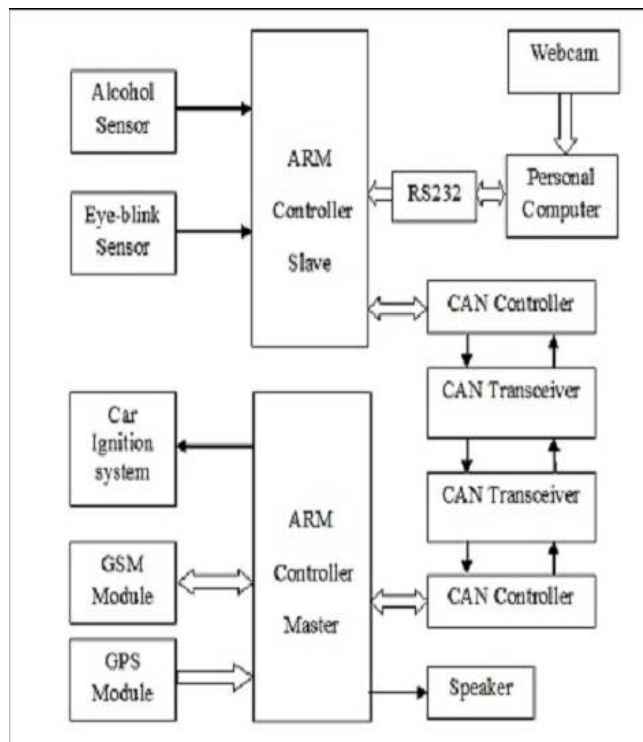

Fig 3: Proposed block diagram

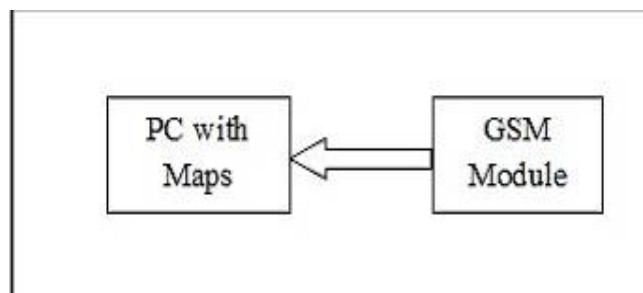

Fig 4: Tracking system

The proposed system in [6] is divided into three parts which are Master, Slave and Tracking section as shown in fig 3 and fig 4. For detection various parameters like driver drowsiness, driver's alcohol content also unauthorized Lane shifting Slave block is responsible and master block is responsible for collecting all the received data from the slave

# International Journal of Innovative Research in Science, Engineering and Technology

(An ISO 3297: 2007 Certified Organization)

Vol. 5, Issue 6, June 2016

and to provide control action such as changing the driver and to control lane shifting. For tracking the vehicle's position there is use of GPS and GSM modules that provides location of the vehicle. The tracking section in fig 4 uses PC installed with maps which interfaced with GSM module. For exchanging the information and for communication both ARM controllers, Slave and Master connected to CAN bus protocol. CAN is used for more faster and reliable communication.

Now I will design implementation of the CAN bus on automated vehicles system. The operation of the CAN protocol has been tested over CORTEX-M31768 microcontroller. For real time transmission of data with less number of wires and large number of devices to communicate CAN protocol is used because it is compatible with many of the devices also it can be implemented in any of the embedded systems. The benefits of automating the guidance regarding automobiles are extensive especially for better utilization of highway space and safety. The proposals regards to automobile automation have been made from at least fifty years but because of technology limitations a practical system has not been possible. Now, new advancement in technology brought a practical system within reach. The proposed system gives the potential benefits regards to automation, related technology requirements, and cost/benefit trades, which gives complete details about the design and implementation the Theft Control System for an automobile, also used to prevent or control the vehicle's theft. Recently propose system use an embedded system with GSM /GPS technology. The recently proposed system, installed in the vehicle system can be easily controlled by the owner of the vehicle which send a text message from owner mobile to the vehicle engine which interfacing with CAN bus and GSM modem. When a cellular network is available and a tracking device is connected then it transmits data to a server and when a network is not available the device stores information in its internal memory and will transmit the stored information to the server as soon as the network becomes available again. The vehicle tracking has been possible by installing a box into the vehicle, by either self-powered with a battery or the vehicle's power system.

## V. CONCLUSION

The survey work mainly focuses on autonomous vehicle control, and history of the automated vehicle development. As number of road accidents increases, then at that time injuries and accident's financial cost are exponentially increasing every year. Therefore need for the countermeasures for reducing the number of severity of traffic accidents, injuries, traffic jams etc. AVCS gives better utilization of road space, gives convenient road transportation and also reduces traffic accidents caused due to driver inattentiveness.

## VI. FUTURE SCOPE

The intelligent driver assistance systems with safety warning systems is still a long way to go. As technology increases in computing power, wireless connectivity, and sensing capacity for vehicles rapidly increase, therefore concept of assisted driving with proactive safety warning is speeding towards implementing in reality. As technology going improves, a vehicle will become just a computer having tires. Also driving on roads will be just like as surfing the Web, there will be traffic congestion but no injuries. Recently advanced driver assistant systems and new sensing technologies can be highly effectively beneficial, along with large body of work on automated vehicles.

## REFERENCES

- [1] Baskar, L.D., Schutter, B.D., Hellendoorn, J. and Papp, Z. "Traffic Control and Intelligent Vehicle Highway Systems: A Survey", IET Intell. Transp. Syst., Vol.5, No.1, pp.38-52, 2011.
- [2] Figueiredo, L., Jesus, I., Machado, J.A.T., Ferreira, K.R. and Martins D.J.L., "Towards the development of intelligent transportation systems". Proc. IEEE Intelligent Transportation Systems, Oakland, CA, USA, 2001.
- [3] Kim, Z. "Robust lane detection and tracking in challenging scenarios", IEEE Trans. Intell. Transp. Syst., Vol.9, No.1, pp.16-26, 2008.
- [4] Lawrence, E.S. "An overview of Intelligent Vehicle Highway Systems (IVHS)", Proc. WES Conference, 1993.
- [5] Sunil Kumar Gurram and James M. Conrad, "Implementation of CAN bus in an autonomous All-Terrain Vehicle", 978-1-61284-738-2/11/\$26.00 ©2011 IEEE
- [6] Ashutosh U. Jadhav, N.M. Wagdarikar, "A Review: Control Area Network (CAN) based Intelligent Vehicle System for Driver Assistance using Advanced RISC Machines (ARM)", International Conference on Pervasive Computing (ICPC) 2015.