

# Comparative Study on the Fatigue Performance of Integral and Conventional Bridges

Athira. N.V <sup>1</sup>, Rahul Krishnan.K <sup>2</sup>P.G. Student, Department of Civil Engineering, Vedavyasa Institute of Technology, Malappuram, Kerala, India<sup>1</sup>Assistant Professor, Department of Civil Engineering, Vedavyasa Institute of Technology, Malappuram, Kerala, India<sup>2</sup>

**ABSTRACT:** In Conventional construction the superstructure typically consists of a series of simply supported spans separated by expansion joints and those spans are resting on bearings at the abutments and intermediate piers. In integral construction the superstructure and abutments form a continuous monolithic structure. In integral bridges work of maintaining joints and bearings are eliminated as it is made integral with intermediate pier. In this project comparison study of fatigue evaluation of conventional and integral bridges are carried out using finite element tool named ANSYS. Life assessment of the two types of bridge is analyzed and compared in this project. Dynamic analysis is also carried out for the bridges in two steps. First a real load history is applied to the bridge to obtain the transient response and then fatigue damage is evaluated.

**KEYWORDS:** ANSYS Workbench 15, Bearings, CATIA V5, Conventional Bridge, Fatigue Analysis, Integral Bridge

## I. INTRODUCTION

A Bridge is a structure built to span physical obstacles without closing the way underneath such as a body of water, valley or road for the purpose of providing passage over the obstacle. There are many different designs that all serve unique purposes and apply to different situations. Designs of bridges vary depending on the function of the bridges, nature of the terrain where the bridge is constructed and anchored, the material used to make it, and the funds available to build it.

Conventional construction, the superstructure typically consists of a series of simply supported spans separated by expansion joints and resting on bearings at the abutments and intermediate piers. The main reason for their popularity is that these structures are simple to design and execute. The sub-structural design is also greatly simplified because of the determinate nature of the structure. In conventional bridges, girders sit on bearings that largely transfers only vertical load to the bridge abutments and thermal expansion and contraction of the bridge is accommodated by expansion joints. Unfortunately, deterioration of these expansion joints, due to seasonal weathering (ice, road salts, and rain), traffic wear, jamming with debris, and other damage mechanisms, leads to corrosion in the bearings; girder ends, and even substructure elements of jointed bridges. Joints and bearings are expensive to buy, install, maintain and repair and more costly to replace

Integral bridges are structures where the superstructure and substructure move together to accommodate the required translation and rotation. The integral abutment bridge concept is based on the theory that due to the flexibility of the piling, thermal stresses are transferred to the substructure by way of a rigid connection between the superstructure and substructure. There are no expansion joints and bearings in the case of integral abutment bridges. Integral bridges are constructed continuous and monolithic with the abutment walls, thus enabling the superstructure and the abutment to act as a single structural unit and assuring a full moment transfer through a moment-resisting connection between them. Monolithic joints and redundancy of bearing result in savings in the cost of the construction and maintenance. Elimination of bearings improves the structural performance during earthquakes. Finally, integral form of construction will require lesser inspection and maintenance efforts. Several structures in India have been built with this concept.

# International Journal of Innovative Research in Science, Engineering and Technology

(An ISO 3297: 2007 Certified Organization)

Vol. 5, Issue 6, June 2016

Bruno Briseghella *et.al*, [10] introduced an innovative beam-to-pier joint and a theoretical and experimental study is conducted to overcome the durability problems of bearings and expansion joints. . M.Naji *et.al* [1] were constructed two-dimensional model of an integral abutment bridge with soil springs around the piles and behind the abutments with finite element ANSYS. L.G.Kalurkar *et.al*, [11] Studied the behaviour of integral abutment bridge in different condition. Shatirah Akib *et.al*, [12] introduced an innovative countermeasure to prevent the impacts and consequences of scouring on integral bridge. Mahesh Tandon *et.al* [9] researched about economical earthquake resistant design of bridges .It includes the study of Plastic hinging and durability of bridge, Superstructure dislodgement prevention and integral bridges ,Base isolation, Energy dissipation and elastomeric bearings, Energy sharing. David Knickerbocker *et.al* [5] Studied the behaviour of two-Span integral bridges unsymmetrical about the Pier Line. Finite element modelling was used in the study using the software ANSYS V. 7.0 and the results are validated with experimental data from two integral bridges.

For this study, an existing conventional bridge is selected and transient analysis is carried out using ANSYS 15. For the same site conditions, an integral bridge with equivalent cross section is modelled, analysed, and results are compared.

## II. GEOMETRY OF BRIDGE

The Mannathikkadavu Bridge is an existing bridge across Thootha River in Malappuram district, Kerala. It has five numbers of 22.32m centre to centre spans. Total length of structure is 111.6m. It has the circular hammer headed piers and open type foundations (600mm in hard rock). The road width is 7.5m with foot path 1.5m on both sides. Elastomeric bearing size of 500x360x99 mm shall be provided for all abutments and piers. For this project we consider only two spans of this bridge.

Table.1.Geometry of bridge

Bridge Components	Description	Size(mm)
Deck Slab	Thickness	240
Girder	Flange	550 x 490
	Web	1440 x 240
Pier	Diameter	1800
Pedestal	Length	1500
	Breadth	800
	Thickness	300
Elastomeric bearing	Length	500
	Breadth	360
	Thickness	99

# International Journal of Innovative Research in Science, Engineering and Technology

(An ISO 3297: 2007 Certified Organization)

Vol. 5, Issue 6, June 2016

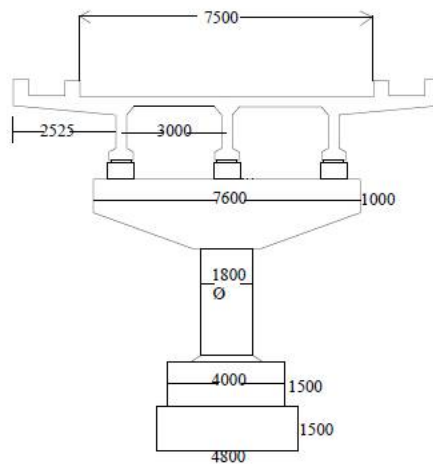

Fig.1. Cross section of bridge

### III. MATERIAL PROPERTIES

Two materials are defined to model the bridge. They are reinforced concrete and neoprene. The properties of the materials are given in table 2.

Table.2. Material properties of bridge

Material	Density (kg/m <sup>3</sup> )	Modulus of Elasticity (MPa)	Poisson's ratio
Reinforced concrete	2500	50000	0.15
Neoprene	9.78E-08	6	0.499

### IV. MODELLING OF BRIDGE

Figures show the models of integral and conventional bridges. The modelling of existing bridges is done using the software CATIAV5- which stands for Computer Aided Three-dimensional Interactive Application - is the most powerful and widely used CAD (Computer Aided Design) software of its kind in the world.

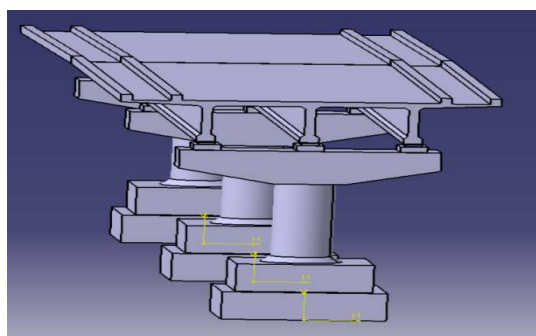

(a)

# International Journal of Innovative Research in Science, Engineering and Technology

(An ISO 3297: 2007 Certified Organization)

Vol. 5, Issue 6, June 2016

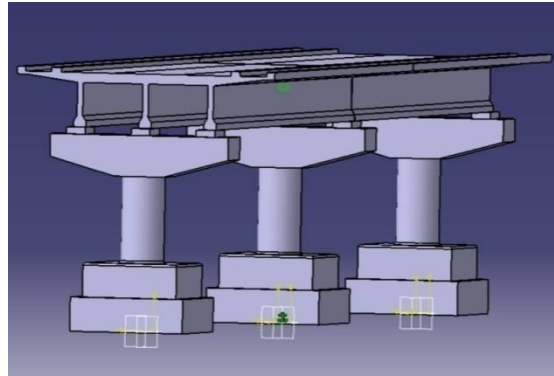

(b)

Fig.2.Model (a) conventional bridge (b) integral bridge

Above diagram shows the model of conventional and integral bridge which reveals the fact that bearings and expansion joints are missing in integral type construction.

## V. LOADING CONDITIONS

As per IRC: 6 – 2014 , IRC Class 70R loading is considered for the analysis .Class 70R loading is applicable only for bridges having carriageway width of 5.3 m and above (i.e.  $1.2 \times 2 + 2.9 = 5.3$ ). The minimum clearance between the road face of the kerb and the outer edge of the wheel or track shall be 1 .2 m.

## VI. ANALYSIS RESULTS AND DISCUSSION

The selected bridges were analysed in ANSYS Workbench 15.Dynamic analysis is carried out for the bridges in two steps. First a real load history is applied to the bridge to obtain the transient response. Second, fatigue damage is evaluated.

Table.3.Analysis results

	Conventional Bridge		Integral Bridge	
	Maximum	Minimum	Maximum	Minimum
Deformation	32.349mm	0mm	2.048mm	0mm
Equivalent Strain	0.8	6.113E-9	.0001	5.54E-9
Equivalent Stress	12.68MPa	9.3638E-6 MPa	9.4738MPa	.00027437
Life	1E+6 Cycles	1E+6 Cycles	1E+6 Cycles	1E+6 Cycles
Damage	1000 Cycles	100 Cycles	1000 cycles	1000 Cycles
Safety Factor	15	15	15	15

From the transient analysis it has been observed that conventional bridge shows maximum deflection of 32.349mm at bearing level where as integral bridge having maximum deflection of 2.048mm.Conventional bridges shows a maximum equivalent strain value of 0.8mm/mm in the bearing portion. The maximum strain value of integral bridge is negligible. Maximum stress value of conventional bridge is 12.68 MPa and that of integral bridge is 9.47MPa.The maximum value of deformation, stress and strain in conventional bridge at the level of bearing leads to the failure of bearing and which results increased maintenance cost. Both bridges show maximum life span of 1E+06 cycles and maximum damage value of 1000 cycles. And both bridges show maximum safety factor of 15. Below figures represents the deformation, equivalent elastic strain, elastic stress, life, damage and safety factor of both the bridges.

## International Journal of Innovative Research in Science, Engineering and Technology

(An ISO 3297: 2007 Certified Organization)

Vol. 5, Issue 6, June 2016

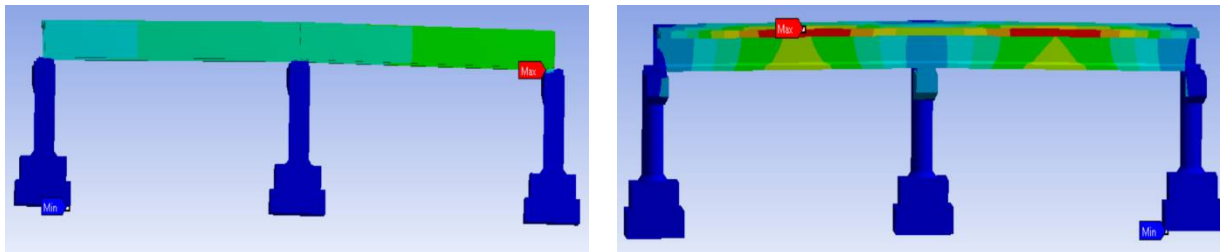

(a) (b)  
Fig.3.Total deformation (a) conventional bridge (b) integral bridge

Above figure shows the total deformation of both integral and conventional bridges from that we understood that maximum total deformation is more in conventional type especially on the bearings.

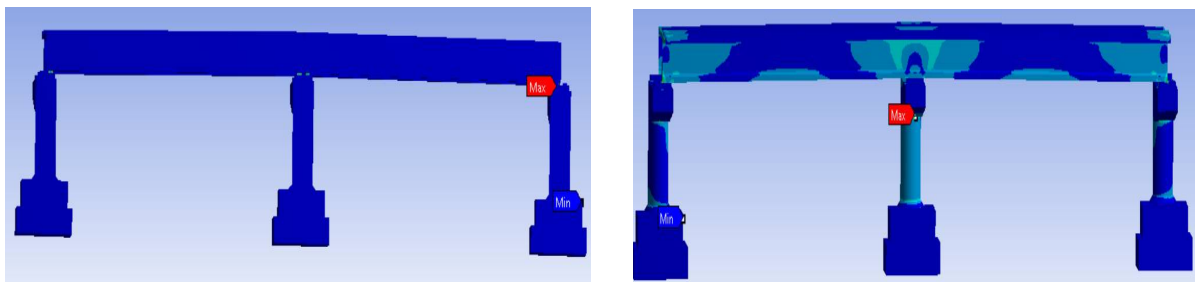

(a) (b)  
Fig.4.Equivalent elastic strain (a) conventional bridge (b) integral bridge

Above figure shows elastic deformation on both the bridges and it is also happened in the bearing level of conventional bridge.

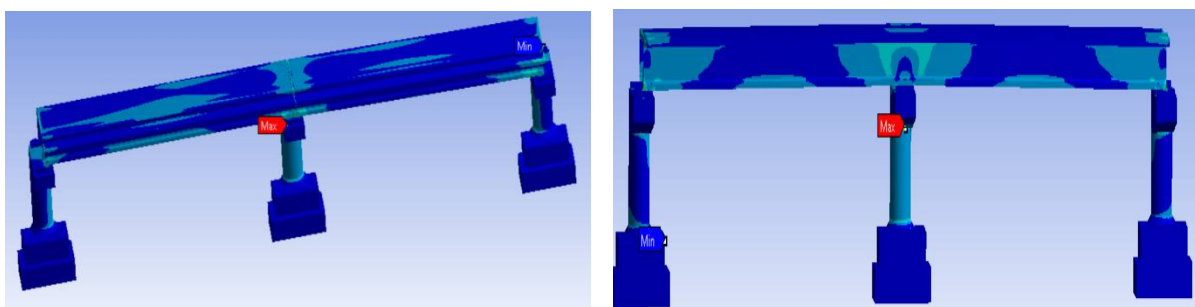

(a) (b)  
Fig.5.Equivalent stress (a) conventional bridge (b) integral bridge

Above figure shows the equivalent stress in both the bridges having more stress in the same bearing area.

# International Journal of Innovative Research in Science, Engineering and Technology

(An ISO 3297: 2007 Certified Organization)

Vol. 5, Issue 6, June 2016

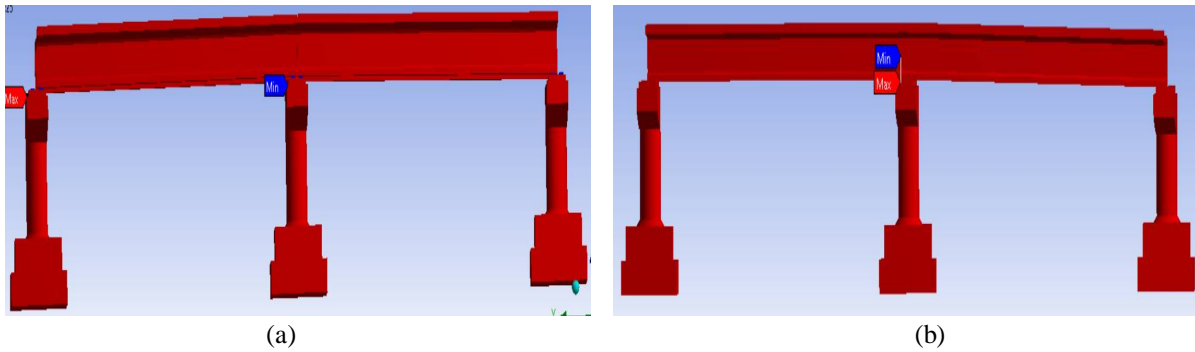

Fig.6. Life (a) conventional bridge (b) integral bridge

Life period for both the bridges is same in the figures which are exhibited above

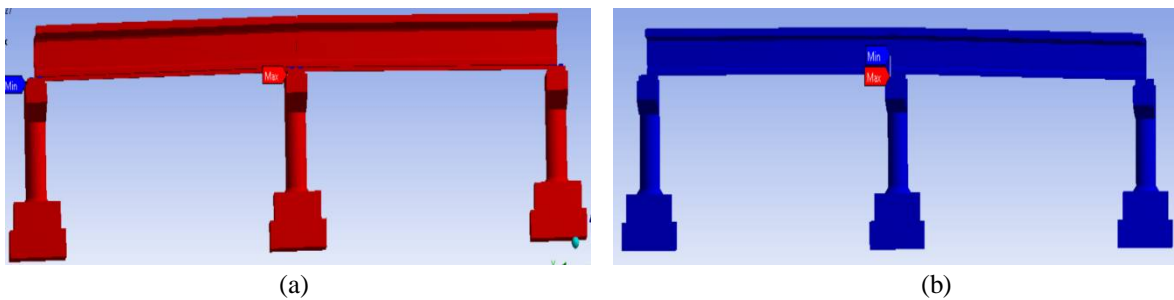

Fig.7. Damage (a) conventional bridge (b) integral bridge

Damage is occurring in the bearing area and expansion joint area in case of conventional bridges. Integral bridge and conventional bridges having maximum damage after 1000 cycles but minimum is 100 cycles in conventional type.

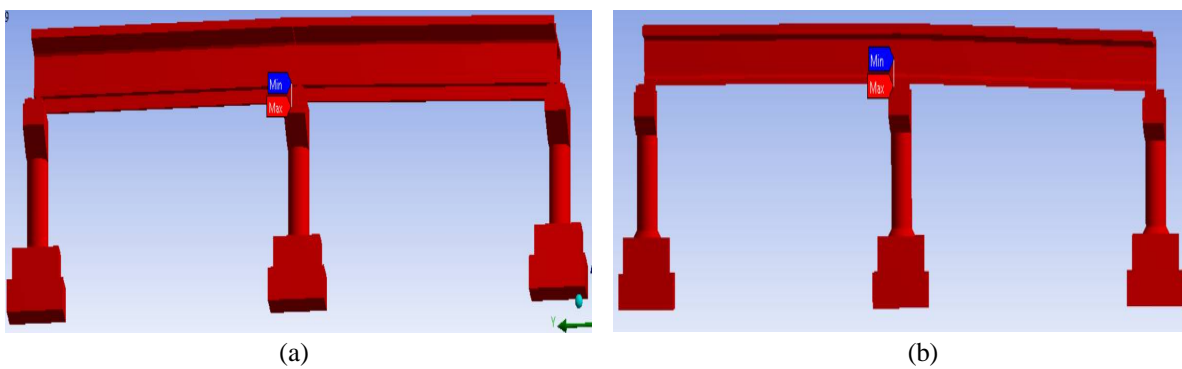

Fig.7. Safety factor (a) conventional bridge (b) integral bridge

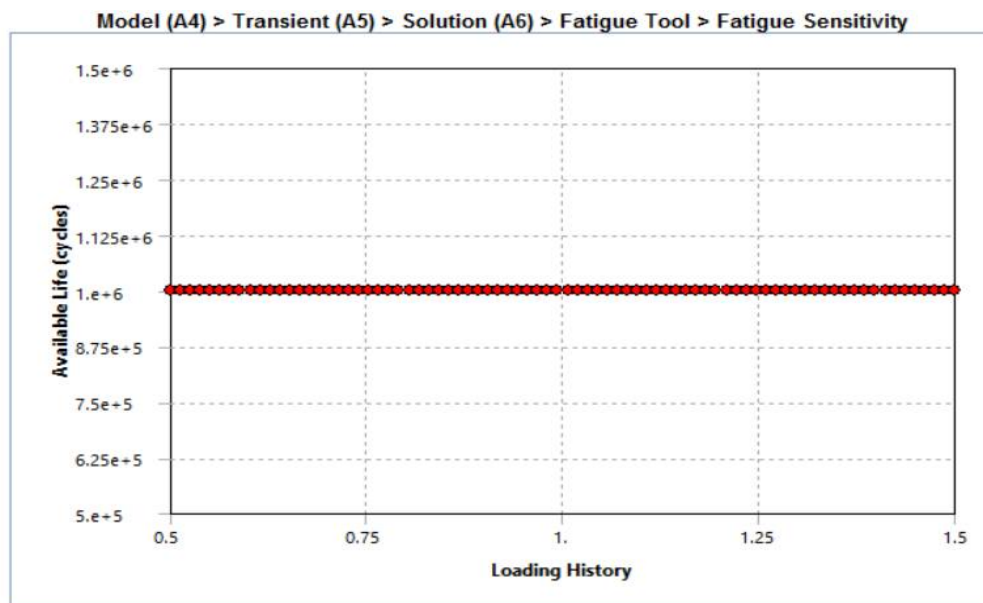

Fig.8.Fatigue sensitivity for integral and conventional bridges

Above plotted graph give the Fatigue sensitivity of both the bridges using ANSYS which shows the fatigue results change as a function of the loading at the critical location of the model. Sensitivity maybe found for life damage or factor of safety.

## VII. CONCLUSION

In this paper conventional bridges and integral bridges were modelled in CATIA V5 and analysed in ANSYS Workbench 15. From the analysis result we understood that maximum deformation and strain is found at the bearings of conventional bridges and the absence of expansion joints in integral bridge gives more durability. The maximum deformation of integral bridge is negligible. Due to the rigid nature of integral bridge, it is found that the value of stress and strain is very less that of conventional one. Both bridges show maximum fatigue life of 1E+6 cycles. Due to the elimination of bearings and expansion joints in integral bridge, initial and maintenance cost is very low comparing with conventional bridge. So it is better to prefer integral construction over conventional type.

## REFERENCES

- [1] M.Naji,A.R,Khalim,“Integral Abutment Bridges-Development of Soil Model for Soil Structure Interaction in Time History Analysis” , International Journal of Engineering Research and Development, Volume 10, Issue 3 (March 2014))
- [2] A.Cunha, E.Caetano, P. Ribeiro, G. Müller, “Seismic performance of straddle-type monorail pre-stressed concrete bridges considering interaction with train under moderate earthquakes”, Proceedings of the 9th International Conference on Structural Dynamics ( July 2014)
- [3] Fabio Biondin , Elena Camnasio and Alessandro Palermo ,“Lifetime seismic performance of concrete bridges exposed to corrosion”,Structure and Infrastructure Engineering, Vol. 10 (December 2014 )
- [4]. Ravi Kiran , Avinash A. , Srinivas R, Kiran ,“Abutment-Pile-Soil Interaction Of A Psc Bridge Under Seismic Loading” , Volume: 03 Special Issue: 03 (May-2014)
- [5] David Knickerbocker, Hardesty, Hanover, Prodyot K. Basu and Edward P. Wasserman, “Behavior of Two Span Integral Bridges,Unsymmetrical About the Pier Line”, The 2005 – FHWA Conference, Integral Abutment and Jointless Bridges [IAJB 2005], Baltimore,Maryland, March 16 – 18, 2005.

## International Journal of Innovative Research in Science, Engineering and Technology

(An ISO 3297: 2007 Certified Organization)

Vol. 5, Issue 6, June 2016

- [6]. Meldi Suhatri, Azlan Adnan, Reza Mohd Vafaee, Patrick Tiong Liq Yee and Ali Karbakhsh , “The seismic performance comparison of integral bridge model by using finite element program and shaking table test”-,International journal of physical science ,vol7(6),(Feb 2012)
- [7]. Shatirah Akib\*, M. M. Fayyadh, S. M. Shirazi, Budhi Primasari and M. F. Idris , “Innovative countermeasure for integral bridge scour”, International Journal of the Physical Sciences Vol. 6(21), (September, 2011)
- [8]. Robert J. Frosch, Michael E. Kreger and Aaron M. Talbott, “Earthquake Resistance of Integral Abutment Bridge”, TRB Subject Code: 25-1 Bridges, Publication No. FHWA/IN/JTRP-2008/11, SPR-2867, Final Report, (May 2009)
- [9]. Mahesh Tandon,” Economical Design Of Earthquake-Resistant Bridges”, , ISET Journal of Earthquake Technology, Paper No. 453, Vol. 42, No. 1,( March 2005)
- [10]. Bruno Briseghella and Tobia Zordan ,“ An innovative steel concrete joint for integral abutment bridges”,Journal of traffic and transportation engineering, Volume 2, Issue 4 (August 2015)
- [11]. L.G.Kalurkar , Shaikh Tausif , “Behavior of Integral Abutment Bridge by Different End Conditions” International journal of current engineering and technology ,Vol 4,(August 2014)
- [12]. Shatirah Akib ,Teuku .K.Syamsura,Moatasem .M.Fayyadh and Budhi Primasari , “ Review of scouring on integral bridge and its possible protection ”,Engineering and technology ,Vol 54,(January 2014)