

Unit Vector Theory based Unified Power Quality Conditioner for Power Quality Improvement

N.C.Kotaiah¹, Dr.K.Chandra Sekhar²

Associate Professor, Department of Electrical & Electronics Engineering, R.V.R & J.C. College of Engineering,
Chowdavaram, Guntur, A.P, India¹

Professor & HOD, Department of Electrical & Electronics Engineering, R.V.R & J.C. College of Engineering,
Chowdavaram, Guntur, A.P, India²

ABSTRACT: In power system networks power quality problem may come from load side or source side. Load side problems cause harmonics and reactive power issues and source side problems cause voltage stability problems. Power quality improvement for sensitive load by a unified power quality conditioner (UPQC) with a distribution system is conferred. UPQC consists of series and shunt compensators for compensation of voltage disturbances and current disturbances. Till now various control strategies are proposed for shunt and series compensators. In this paper the instantaneous unit vector control theory under various loading conditions is analysed. With the proper control strategy UPQC can compensate the harmonic and reactive power of the load. MATLAB/SIMULINK based model is developed and simulation results are presented for various loading conditions.

KEYWORDS: unified power quality conditioner (UPQC), Instantaneous d-q theory, harmonic currents, reactive power and voltage distortion,

I. INTRODUCTION

Due to the presence of linear and non-linear loads the use of power quality compensator in distribution network is increased from time to time. The non-linear loads draw harmonics and linear loads draw reactive power from the grid. This current drawn by harmonic load distorts the voltage at the utility grid and consequently distorts the operation of sensitive loads. By using UPQC [1]-[2] not only improves power quality, it also regulates voltage for the sensitive loads. UPQC comprises two compensators such as series compensators and shunt compensators [3], [4]. The shunt compensators control by non-sinusoidal current reference and the series compensators control the distorted voltage supply i.e. accountable for compensating the grid voltage. These current and voltage references may be obtained through advanced control strategies [4],[5]. Some work shows effective technique for shunt and series compensators that uses the sinusoidal references, but the requirement of harmonic extraction is gaining importance so that it does not affect the smooth operation of various loads.

Many control strategies have been developed for UPQC. However still performance of UPQC is in contradiction under various loading conditions. In this paper shunt compensator reference current is generated by using unit vector current theory and series compensator voltage is derived from Synchronous Reference Frame theory.

II. UPQC TOPOLOGY, CONTROL STRATEGY

UPQC can eliminate both current and voltage quality problems. By using a unified power quality conditioner (UPQC) [5]-[6], it is likely to certify a regulated voltage for the loads is balanced with little harmonic distortion at the grid. The UPQC consists of two voltage source converters. One will act as shunt compensator and other will act as series

compensator the volt-ampere rating of the shunt compensator is selected based on harmonic contents of the load. The volt-ampere rating of series compensator is selected based on voltage sags and voltage swells. The dc-link voltage of the UPQC is selected based on the peak value of the supply voltage.

Fig.1 shows the complete block diagram of proposed UPQC topology. It consists of two voltage source converters connected back to back, the shunt converter is connected to PCC through inter facing Inductors, linear and non-linear loads that are considered. Series converter is connected in series with grid through injection transformers and LC filters. Here voltage sag and swell problems are occurred from grid side. For harmonic and reactive power compensation the dc-link voltage must be greater than supply voltage peak value with some multiplication factor. But for sag and swell compensations dc-link voltage at most equal to supply peak voltage. For compensation of harmonics, reactive power, voltage sags and swell the value of dc-link voltage must be chosen based on shunt compensator.

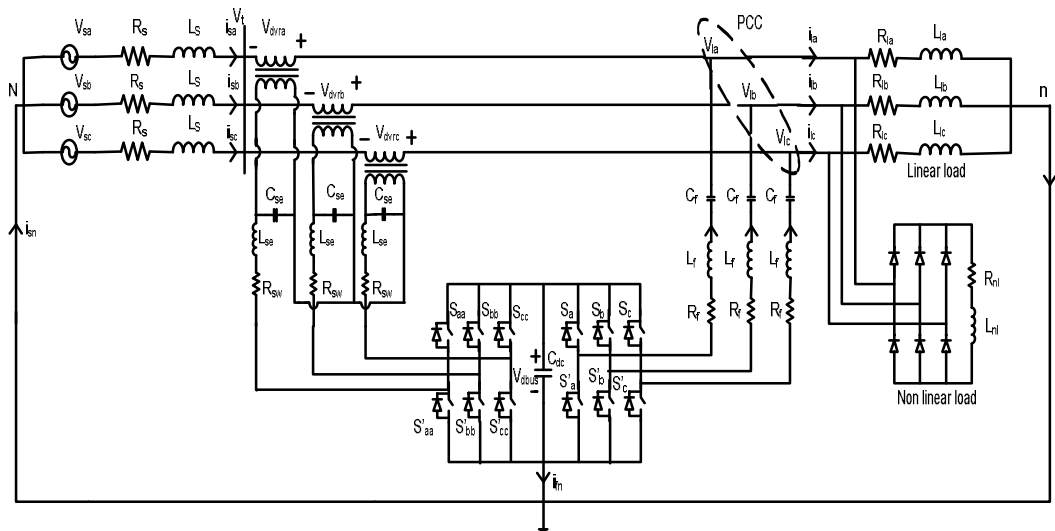

Fig 1. Block diagram of the proposed UPQC topology.

III. SHUNT CONVERTER WITH UNIT VECTOR CONTROLLER

Instantaneous unit vector control theory is used for reference current generation for non linear load. Calculations are similar to instantaneous power theory, but d-q load currents are obtained from equations (1) and (2). Here the load current is measured in a-b-c frames, then converted to rotating

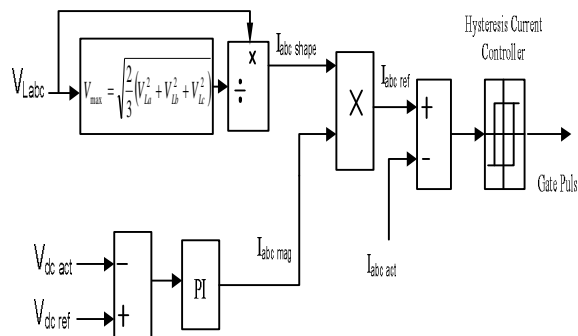

Fig .2. Block Diagram of shunt Controlled UPQC.

Unit Vector Template:

$$U_a = \sin(\theta)$$

International Journal of Innovative Research in Science, Engineering and Technology

(An ISO 3297: 2007 Certified Organization)

Vol. 5, Issue 6, June 2016

$$U_b = \sin\left(\theta - \frac{2\pi}{3}\right)$$

$$U_c = \sin\left(\theta + \frac{2\pi}{3}\right) \quad (1)$$

The dc-link voltage error $V_{dcerr(n)}$ at nth sampling instant is given as:

$$V_{dcerr(n)} = V_{dc(n)}^* - V_{dc(n)} \quad (2)$$

The output of discrete-PI regulator at sampling instant is expressed as

$$I_m(n) = I_m(n-1) + K_{PV_{dc}}(V_{dcerr(n)} - V_{dcerr(n-1)}) + K_{IV_{dc}}V_{dcerr(n)} \quad (3)$$

Where $K_{PV_{dc}} = 10$ and $K_{IV_{dc}} = 0.05$ are proportional and integral gains of dc-voltage regulator. The instantaneous values of reference three phase grid currents are computed as

$$\begin{aligned} I_a^* &= I_m \cdot U_a \\ I_b^* &= I_m \cdot U_b \end{aligned} \quad (4)$$

$$I_c^* = I_m \cdot U_c$$

The reference grid currents (I_a^* , I_b^* , I_c^*) are compared with actual grid currents (I_a , I_b , I_c) to compute the current errors as

$$\begin{aligned} I_{aerr} &= I_a^* - I_a \\ I_{berr} &= I_b^* - I_b \\ I_{cerr} &= I_c^* - I_c \\ I_{nerr} &= I_n^* - I_n \end{aligned} \quad (5)$$

These current errors are given to hysteresis current controller. The hysteresis controller then generates the switching pulses (P_1 to P_8) for the gate drives of grid-interfacing inverter. The average model of 4-leg inverter can be obtained by the following state space equations

$$\begin{aligned} \frac{dI_{nva}}{dt} &= \frac{(V_{Inva} - V_a)}{L_{sh}} \\ \frac{dI_{nvb}}{dt} &= \frac{(V_{Invb} - V_b)}{L_{sh}} \\ \frac{dI_{nvc}}{dt} &= \frac{(V_{Invc} - V_c)}{L_{sh}} \\ \frac{dI_{nvn}}{dt} &= \frac{(V_{Invn} - V_n)}{L_{sh}} \end{aligned} \quad (6)$$

$$\frac{dV_{dc}}{dt} = \frac{(I_{Invad} + I_{Invbd} + I_{Invcd} + I_{Invnd})}{C_{dc}} \quad (7)$$

Where V_{Inva} , V_{Invb} , V_{Invc} and V_{Invn} are the three-phase ac switching voltages generated on the output terminal of the inverter. These inverter output voltages can be modelled in terms of instantaneous dc bus voltage and switching pulses of the inverter as

$$\begin{aligned} V_{Inva} &= \frac{(P_1 - P_4)}{2} V_{dc} \\ V_{Invb} &= \frac{(P_3 - P_6)}{2} V_{dc} \\ V_{Invc} &= \frac{(P_5 - P_2)}{2} V_{dc} \\ V_{Invn} &= \frac{(P_7 - P_8)}{2} V_{dc} \end{aligned} \quad (8)$$

Similarly the charging currents I_{Invad} , I_{Invbd} , I_{Invcd} on dc bus due to the each leg of inverter can be expressed as

$$\begin{aligned} I_{Invad} &= I_{Inva}(P_1 - P_4) \\ I_{Invbd} &= I_{Invb}(P_3 - P_6) \end{aligned}$$

$$\begin{aligned} I_{Invcd} &= I_{Invc}(P_5 - P_2) \\ I_{Invad} &= I_{Inva}(P_7 - P_8) \end{aligned} \tag{9}$$

IV. SERIES CONTROLLER FOR UPQC

Figure.3.shows the block diagram of series controlled UPQC. It is the dual of the shunt APF, and is able to compensate for distortion in the power line voltages, making the voltages applied to the load sinusoidal (compensating for voltage harmonics). The filter consists of a voltage-source inverter (behaving as a controlled voltage source) and requires three single-phase transformers to interface with the power system. The series active filter does not compensate for load current harmonics but it acts as high-impedance to the current harmonics coming from the power source side. Therefore, it guarantees that passive filters eventually placed at the load terminals will not drain harmonic currents from the rest of the power system. Another solution to solve the load current harmonics is to use a shunt active filter together with the series active filter, so that both load voltages and the supplied currents are guaranteed to have sinusoidal waveforms

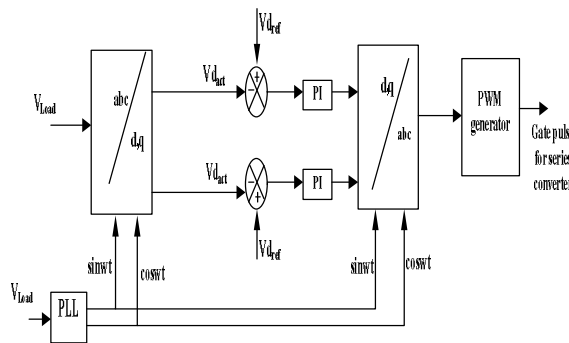

Fig.3.Block Diagram of Series Controlled UPQC.

SERIES CONTROLLER EQUATIONS:

$$\begin{bmatrix} V_d \\ V_q \\ V_o \end{bmatrix} = \frac{1}{\sqrt{3}} \begin{bmatrix} 1 & -\frac{1}{2} & -\frac{1}{2} \\ 0 & \frac{\sqrt{3}}{2} & -\frac{\sqrt{3}}{2} \\ \frac{1}{\sqrt{2}} & \frac{1}{\sqrt{2}} & \frac{1}{\sqrt{2}} \end{bmatrix} \begin{bmatrix} \coswt & \sinwt \\ -\sinwt & \coswt \end{bmatrix} \begin{bmatrix} V_a \\ V_b \\ V_c \end{bmatrix} \tag{10}$$

V.MATLAB/SIMULINK ANALYSIS

Therefore by using the above control strategies for series active power filter, shunt active power filter combindly helps to design a UPQC .The following MATLAB/SIMULINK model. Different cases of the UPQC, Case I: Harmonics and Re-active power compensation with unit vector Controlled Shunt converter, Case II: Voltage Sag compensation with Series Converter, Case III: Harmonics, Re-active power and Voltage Compensation with both Series and shunt converter based UPQC.

Fig.5. shows the control strategies for shunt converter of UPQC.

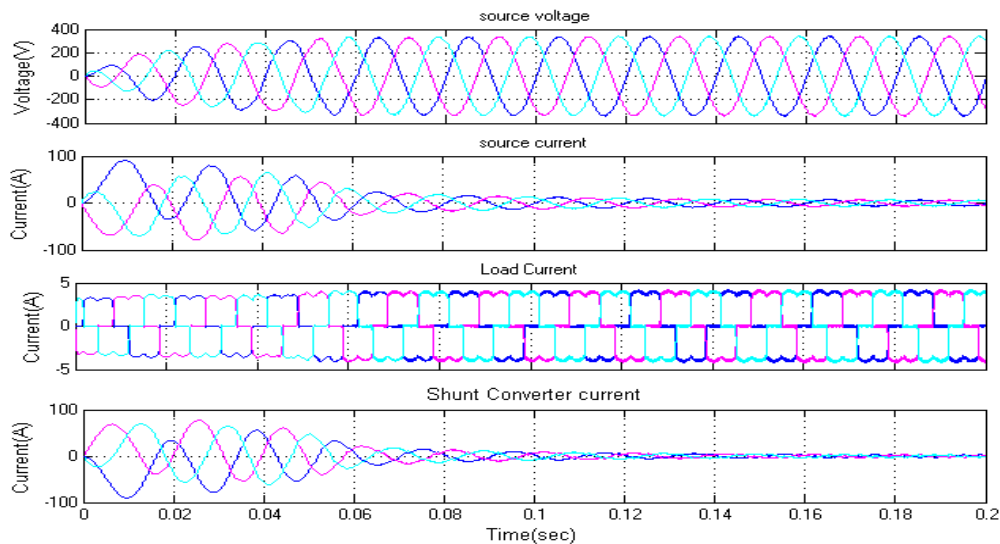

Fig.6. Simulated output wave form of Source voltage, Source current, Load current and Shunt Converter current.

Fig.6. shows the source voltage and current, load current and shunt converter current for harmonic and re-active power compensation with unit vector controlled shunt converter.

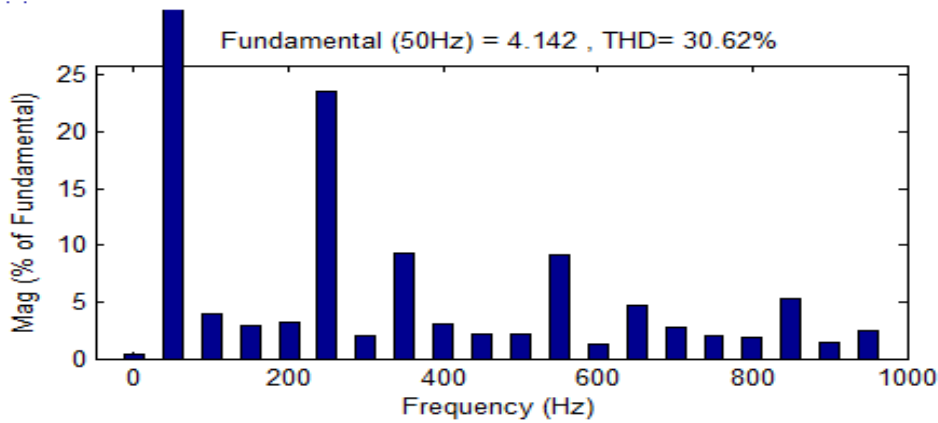

Fig.7. THD of Load Current shows 30.62%.

Fig.7. shows the total harmonic distortion of load current shows 30.62%.

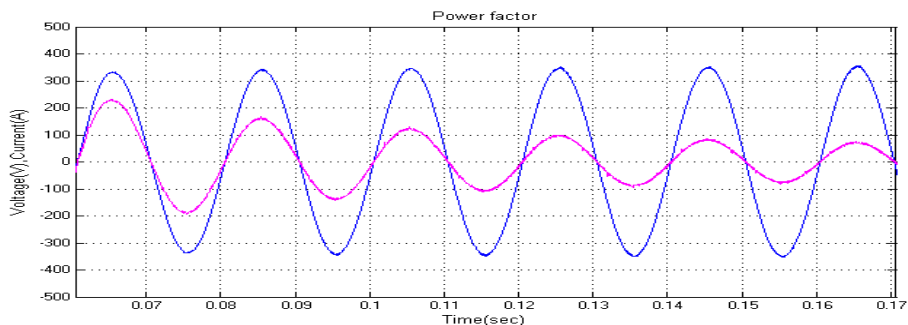

Fig.8. Source Voltage and Source Current with unit vector controlled Shunt Converter.

Fig.8. shows the source voltage and current with unit vector controlled shunt converter.

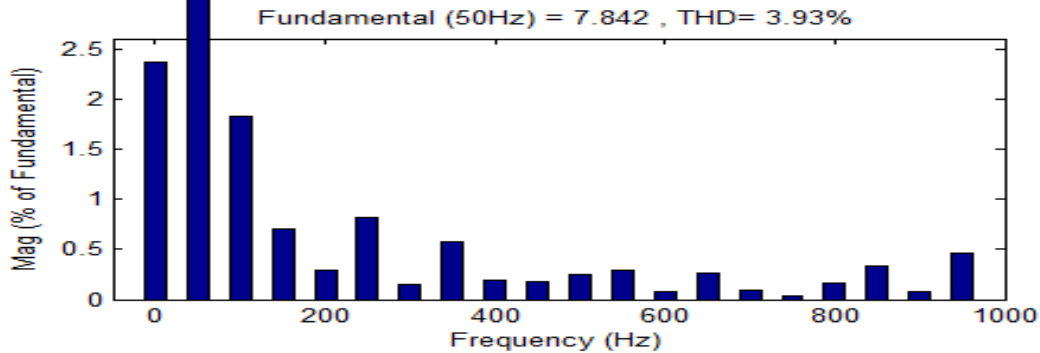

Fig.9. Total Harmonic Distortion of Source Current shows 3.93%.

Fig.9.total harmonic distortion of source current with unit vector controlled shunt converter shows that it is reduced to 3.05%.

Case II: Voltage Sag compensation with Series Converter

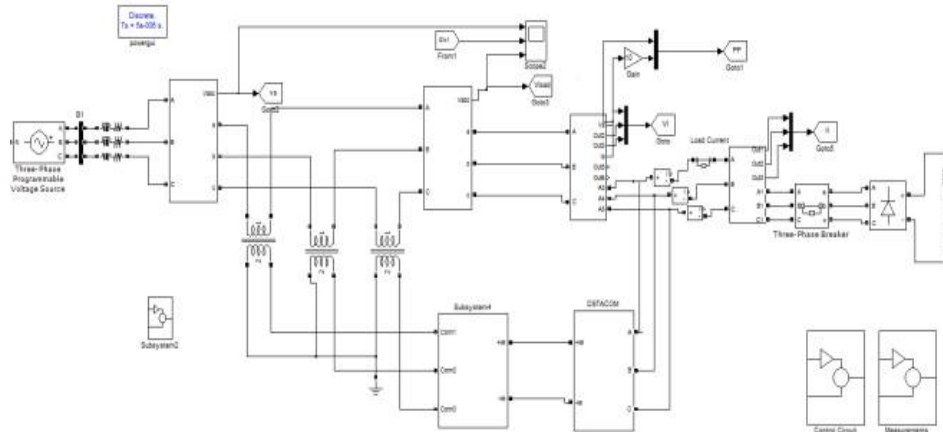

Fig.10. Simulink model of Voltage Sag compensation with Series converter of UPQC.

Fig.10. shows the Matlab/Simulink model of power system network with voltage sag compensation with series converter.

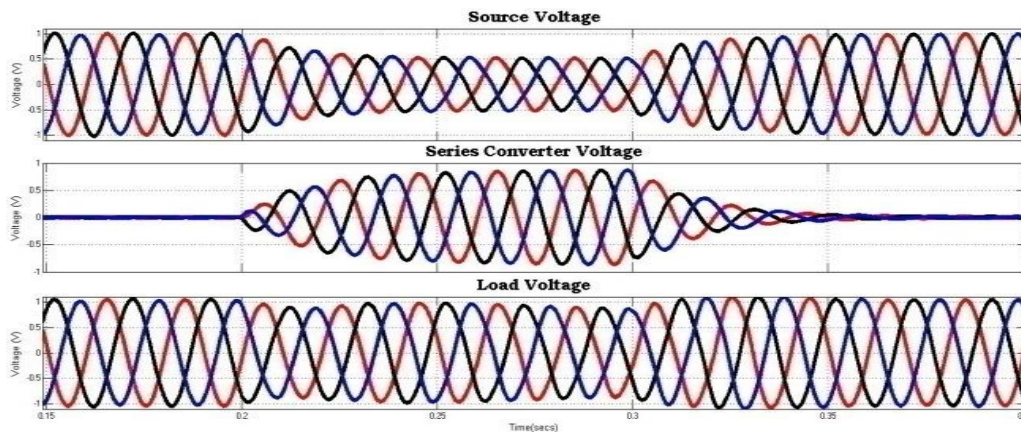

Fig .11.Simulated output wave form of Source Voltage with sag, Series converter injected voltage and load voltage.

Fig.11. shows the output wave form of source voltage with sag, series converter injected voltage and load voltage with voltage sag compensation with series converter.

Case III: Harmonics, Re-active power and Voltage Compensation with both Series and shunt converter based UPQC.

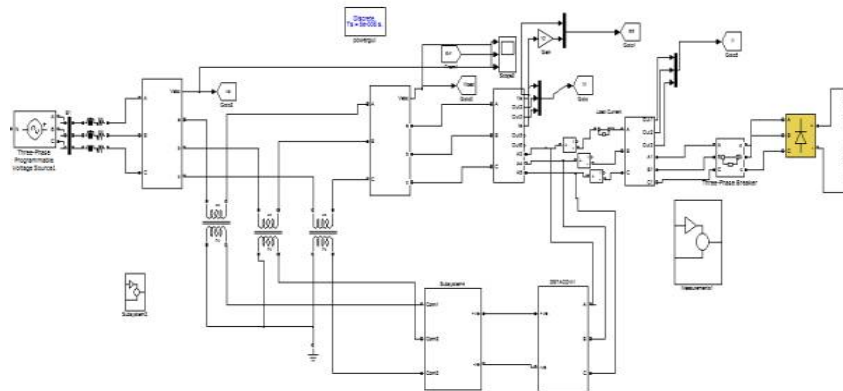

Fig.12. Simulink model of Harmonics, Re-active power and Voltage sag compensation with Shunt and Series converter of UPQC.

Fig.12.shows the Matlab/Simulink model of power system network with harmonics re-active and voltage sag compensation with shunt and series converters of UPQC.

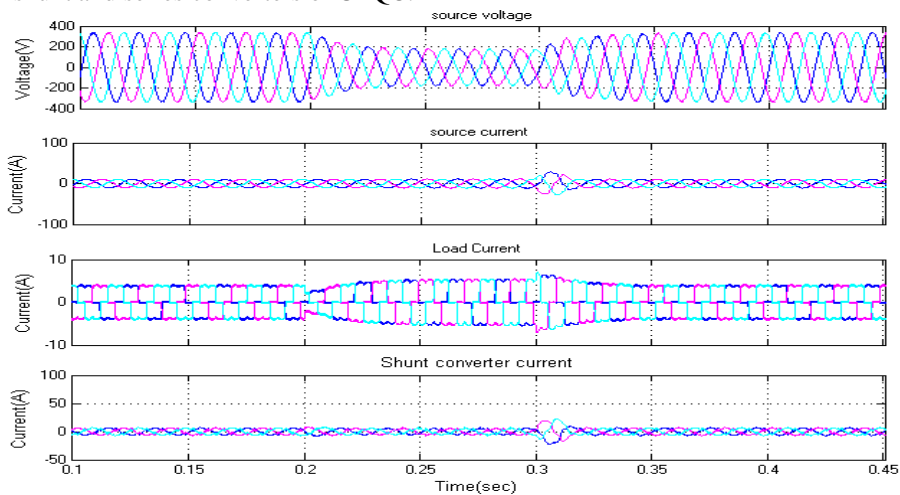

Fig.13. Simulated output wave forms of Source voltage, Source current, Load current and Shunt converter injected current.

Fig.13.shows the output wave forms of source voltage and current, load current and shunt converter injected current.

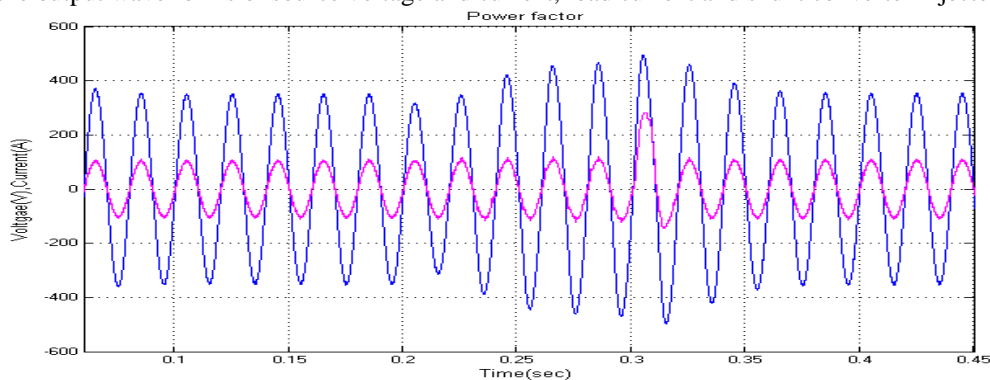

Fig.14. Source Voltage and Source Current with unit vector controlled Shunt Converter.

Fig.14. shows the source voltage and current with unit vector controlled shunt converter.

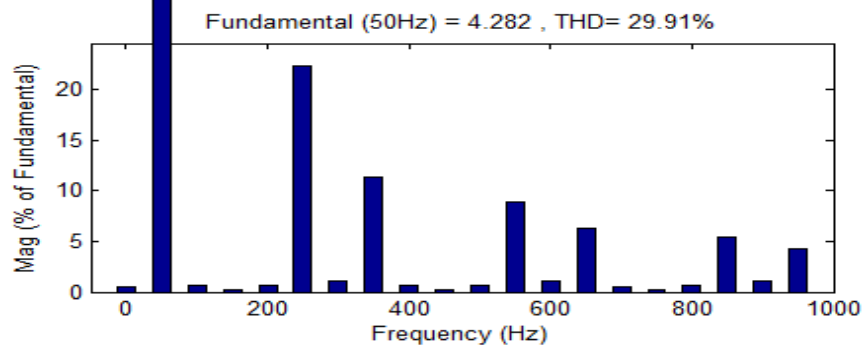

Fig.15. THD of Load Current shows 29.91%.

Fig.15. shows the total harmonic distortion of load current shows 29.91%.

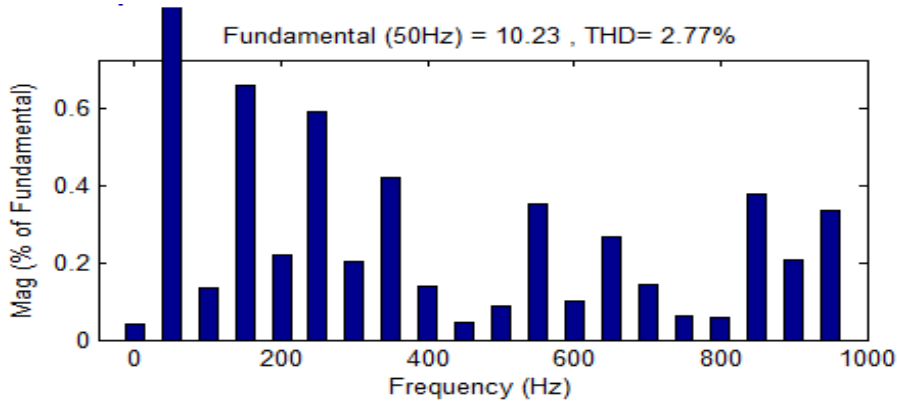

Fig.16. Total Harmonic Distortion of Source Current shows 2.77%.

Fig.16. total harmonic distortion of source current with unit vector controlled shunt converter shows that it is reduced to low value 2.77%

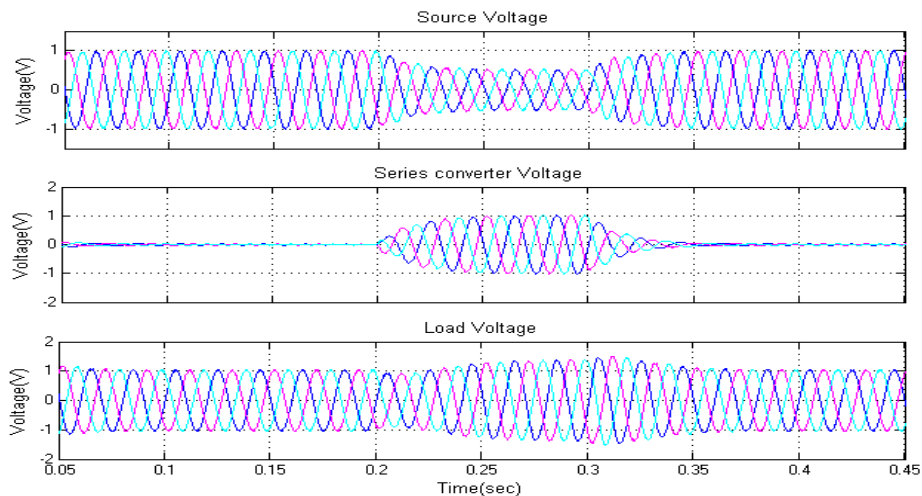

Fig.17. Simulated output wave form of Source Voltage, Series converter injected voltage and load voltage under both harmonic load and voltage distortion.

Fig.17. shows the output wave form of source voltage, series converter injected voltage and load voltage under both harmonic load and voltage distortion.

International Journal of Innovative Research in Science, Engineering and Technology

(An ISO 3297: 2007 Certified Organization)

Vol. 5, Issue 6, June 2016

Table

| Parameter | Value |
|----------------------|----------------------|
| Source Voltage | 320 V |
| Source Impedance | $(0.1+j0.28) \Omega$ |
| DC Link Capacitance | 3000 μ F |
| Load resistance | 150 Ω |
| Load Inductance | 30mH |
| Interfacing Inductor | 8.98nH |

VI.CONCLUSION

In this paper UPQC topology has been proposed with unit vector controlled shunt converter which has the ability to compensate voltage sags and current harmonics at the load side. Thus large harmonic problems with non linear loads and distorted voltage magnitudes are also avoided. In this work a unit vector theory based control algorithm is used for shunt converter and DQ control strategy is used for series converter. The system is tested for three conditions case 1: only sag swells are considered and series compensation is tested and results are presented, case 2: only harmonics are considered and shunt compensation is tested and results are presented, case 3: voltage sag and harmonics are considered and results are presented. Simulation results clearly show that power quality problems are well mitigated with vector controller based UPQC.

REFERENCES

- [1] M. Bollen, Understanding Power Quality Problems. Piscataway, NJ, USA: IEEE, 2000, ch. 1, pp. 1–35.
- [2] H. Fujita and H. Akagi, "Voltage-regulation performance of a shunt active filter intended for installation on a power distribution system," IEEE Trans. Power Electron., vol. 22, no. 3, pp. 1046–1053, May 2007.
- [3] K. Kowalenko, Distributed Power Offers an Alternative to Electric Utilities, vol. 25, IEEE Press, Piscataway, NJ, 2001.
- [4] F. Blaabjerg, Z. Chen, S.B. Kjaer, Power electronics as efficient interface in dispersed power generation systems, IEEE Trans. Power Electron. 19 (September (5)) (2004) 1184–1194.
- [5] M. Aredes, K. Heumann, and E. Watanabe, "An universal active power line conditioner," IEEE Trans. Power Del., vol. 13, no. 2, pp. 545–551, Apr. 1998.
- [6] K. Dai, P. Liu, G. Wang, S. Duan, and J. Chen, "Practical approaches and novel control schemes for a three-phase three-wire series-parallel compensated universal power quality conditioner," in Proc. IEEE APEC Expo., 2004, vol. 1, pp. 601–606.
- [7] H. Fujita and H. Akagi, "The unified power quality conditioner: The integration of series and shunt-active filters," IEEE Trans. Power Electron., vol. 13, no. 2, pp. 315–322, Mar. 1998.
- [8] F.Z. Peng, Editorial: Special issue on distributed power generation, IEEE Trans. Power Electron. 19 (September (5)) (2004) 1157–1158.
- [9] T.S. Perry, Deregulation may give a boost to renewable resources, IEEE Spectr. (January) (2001) 87.
- [10] H. Fujita, H. Akagi, The unified power quality conditioner: the integration of series and shunt active filters, IEEE Trans. Power Electron. 13 (March (2)) (1998) 315–322.
- [11] Yash Pal, A. Swarup, Bhim Singh, "A control strategy based on UTT and I Cos Φ theory of three-phase, four wire UPQC for power quality improvement" International Journal of Engineering, Science and Technology Vol. 3, No. 1, 2011, pp. 30-40.

International Journal of Innovative Research in Science, Engineering and Technology

(An ISO 3297: 2007 Certified Organization)

Vol. 5, Issue 6, June 2016

BIOGRAPHY



N.C. Kotaiah has obtained B.Tech degree in Electrical & Electronics Engineering from Regional Engineering College, Calicut (RECC), Kerala, India in the year 1996 and Post Graduation M.Tech. Electrical Power Engineering from JNTU, Kakinada in the year 2005. He is currently a Ph.D. student in the EE Dept. at ANU, Nagarjuna Nagar, Guntur. He is having a teaching experience of 17 years and now associated with R.V.R & J.C. College of Engineering, Guntur, Andhra Pradesh, India. His research interests related to FACTS - converter based compensators for enhancement of power quality, high voltage engineering and power system protection.



Dr.K.Chandra Sekhar received his B.Tech degree in Electrical & Electronics Engineering from V.R.Siddartha Engineering College, Vijayawada, India in 1991 and M.Tech with Electrical Machines & Industrial Drives from Regional Engineering College, Warangal, India in 1994. He Received the PhD, degree from the J.N.T.U, Hyderabad, India in 2008. He is having 19 years of teaching and research experience. He is currently Professor&Head in the Department of Electrical & Electronics Engineering, R.V.R & J.C.College of Engineering Guntur, India. His Research interests are in the areas of Power Electronics, Industrial Drives & FACTS

Controllers.