

# Design, Fabrication and Working of In-House Spin Coating Unit for Thin Film Deposition

C.Thirunavukkarasu<sup>1</sup>, K.K. Saranya<sup>2</sup>, B.Janarthanan<sup>3</sup>, J. Chandrasekaran<sup>4</sup>

Research Scholar, Department of Physics, Karpagam University, Eachanari (PO), Coimbatore, Tamil Nadu, India<sup>1</sup>

P.G. Student, Department of Physics, Karpagam University, Eachanari (PO), Coimbatore, Tamil Nadu, India<sup>2</sup>

Associate Professor, Department of Physics, Karpagam University, Eachanari (PO), Coimbatore, Tamil Nadu, India<sup>3</sup>

Associate Professor, Department of Physics, Sri Ramakrishna Mission Vidyalaya College of Arts and Science, Coimbatore, Tamil Nadu, India<sup>4</sup>

**ABSTRACT:** This paper attempts to design and fabricate a spin coating unit with locally available materials for the deposition of thin films over a glass substrate. The proposed unit is constructed with high speed DC motor, spinning disk, substrate holder, regulated power supply, chuck etc. The thickness of the thin film is influenced by the spinning rate as expected and the spinning rate of the proposed unit varies between 200-6500 rpm. The unit is tested to coat ZnO thin film on glass substrate and results confirm the dependence of thickness of the thin film on the spin speed.

**KEYWORDS:** Spin coating, RPM, spin speed, ZnO thin film

## I. INTRODUCTION

Around the world, it was endeavored for depositing thin films on different substrates by different methods. The spin coating method is one of the viable and easy technique of all methods to achieve uniform coating of thin films on the given substrate but only in the range of nanometer. An indigenous in-house spin coater for coating thin film on the given substrate using rotor consists of AC motor to achieve speeds of 1200 rpm, 2400 rpm and 3600 rpm respectively and it was designed and tested by Sevvanthiet *al.* [1]. Homogeneous and heterogeneous single and multiple layered thin films have been made with an optimal spin speed. The results confirmed the prevention of film from smooth formation, avoiding accumulation and multiple nucleations. Ilican and Caglar [2] prepared ZnO thin film on a glass substrate using sol-gel spin coating method. The influence of deposition parameters on structural, optical and electrical properties of ZnO thin films has been analyzed. The result of characterization confirmed the suitability of ZnO thin films as a photovoltaic material. Dietrich Meyerhofer [3] proposed a model to evaluate the thickness of the film prepared from solution by spinning as a function of various processing parameters. A result of the model has close agreement with the experimental observations, the film thickness depends on spinning speed, initial viscosity and evaporation rate have also been confirmed.

Mitzi *et al.* [4] fabricated thin film field effect transistors (TFTs) with n-type transport, large current densities and mobilities greater than that of existing spin coated semiconductors. Results of the study proved the applicability of spin coating technique for a range of metal chalcogenides and variety of thin film-based devices. Using affordable components, spin coating unit was designed and proposed a theory by Tyona [5]. The system consists of a high speed DC motor, proximity sensor, micro-controller and LiquidCrystal Display (LCD). ZnO film has been prepared using the spin coating unit and the characterization results including SEM, XRD, UV-Vis, FT-IR and RBS which has shown good results compared with standard equipment. Niranjansahuet *al.* [6] wrote a mathematical model for the mechanism involved during thin film formation. The results showed the relation between film thickness and film radius spreading with time. MohuaFardousiet *al.* [7] designed and tested a simple low cost spin coater using DC motor and electronic circuits. The spinning speed of 350 to 3800 RPM has been achieved and controlled manually by 11 steps. The theory behind the spin coating unit was explained by Scriven [8] and found that the increase of angular speed in spinning which decreases the thickness of the film. Moreover the thickness of the film is influenced by viscosity and

# International Journal of Innovative Research in Science, Engineering and Technology

(An ISO 3297: 2007 Certified Organization)

Vol. 5, Issue 6, June 2016

concentration of the solution and solvent. Chii-Ruey Lin *et al.* [9] fabricated a diamond based antireflective coatings using nucleation enhancement procedure and microwave plasma enhanced chemical vapor deposition. Results of the study confirmed the feasibility of spin coating procedure for large scale production of diamond film as an AR in optoelectronic devices.

Manikandan [10] constructed a compact spin coating machine for working with low power consumption. The spinning speed and flow rate of the liquid has been controlled by the arm processor LPC 11U24. It shows that films were prepared using the spin coater has good uniformity. Mohammad Meftahul Ferdous *et al.* [11] designed a spin coater which can achieve a spinning speed of 3000 rpm in manual control. The result shows the cost-effectiveness and simple techniques for preparing film of uniform thickness. Ya-yu Huang and Kan-sen Chou [12] successfully predicted sol viscosity using an empirical equation i.e., ratio of reaction time to gel time. It has been confirmed that the film thickness correlated well with sol viscosity and spin speed. Yimsiri and Mackley [13] reported the experimental results of light-emitting polymer solution by spin and dip coating methods. Solvent evaporation and solution viscosity have been incorporated as modifications in the existing dip and spin coating methods. Results of the study are in reasonable agreement with final film thickness. Dewiet *et al.* [14] studied the effect of spinning rate on the microstructure, grain size, surface roughness and thickness of Barium strontium titanate thin film. It has been found that increase in spinning rate results in decrease in thickness of films with good roughness and vice versa.

In the present work, since effort has been taken to design and fabricate a spin coating unit using DC motor with required electronic circuits for controlling the spinning rate of the chuck. ZnO thin films have been attempted using the proposed unit and analyzed.

## II. MATERIALS AND METHOD

### II. 1 Construction for Spin Coating

Figure.1 and 2 show the photograph of the fabricated in-house spin coating unit with spinning rate ranging from 200 to 6500 rpm. The fabricated unit can be used to coat sample on substrates such as glass, metal and silicon wafers. DC regulated variable power supply is used to vary the spinning rate of the device using potentiometer which is connected to the output of power supply. The potentiometer output is given to the DC motor to vary the spinning rate of the motor. The substrate holder is made on the spinning disk that mounted on the axle of the DC motor. When the DC motor rotates, the spinning disk also rotates along with the substrate holder. Transparent chuck is made up of acrylic sheet which is used to enclose the spinning disk to avoid sprinkling of the experimental solution. A small hole on the top of the chuck is to insert a syringe with the solution to coat on the substrate. The center of the substrate and chuck coincide with each other to avoid inhomogeneous coating. The centrifugal force of each drop of the solution on the substrate in the center that reduces the size of the particle as well as homogenous distribution of solution throughout the substrate.

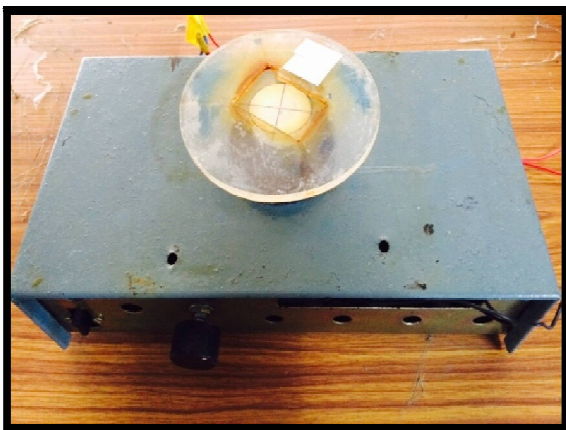

Fig.1. Spin coating machine.

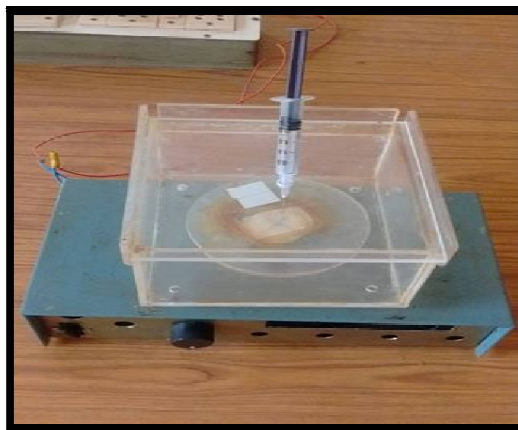

Fig.2. Solution deposited on glass substrate

## International Journal of Innovative Research in Science, Engineering and Technology

(An ISO 3297: 2007 Certified Organization)

Vol. 5, Issue 6, June 2016

### II.1.1 Power Supply Circuit Using 0-30V

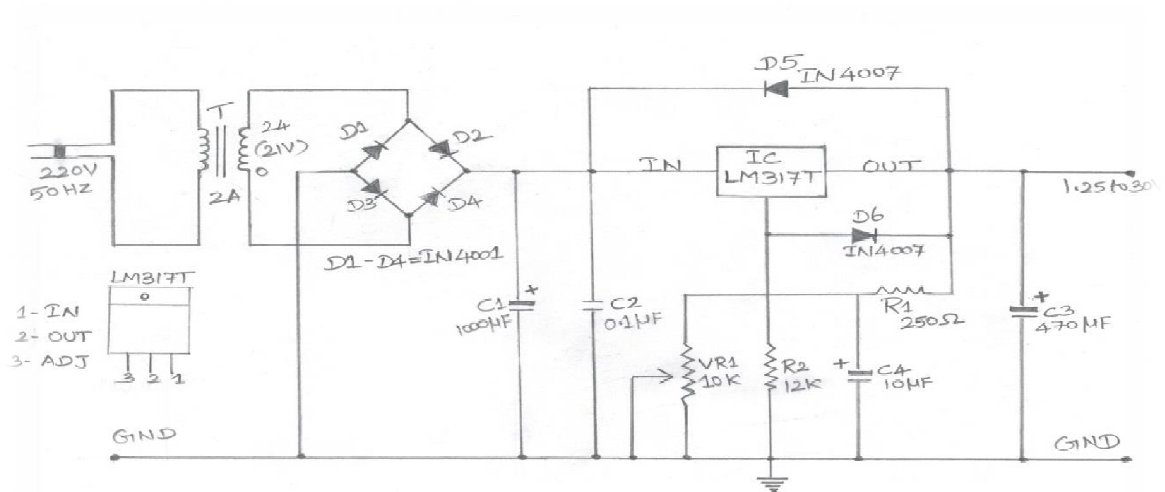

Fig.3. Variable power supply (0-30V)

The schematic circuit diagram of the variable power supply is in the Fig.3 and consists of 12 V step down transformer, diodes, capacitors, 10KΩ variable pot, resistors and IC LM317T. The input AC voltage of definite frequency step down to 12V AC and it is given to the bridge constructed using four diodes. The output of the bridge rectifier with ripples is filtered by the capacitor and the output DC voltage is fed into IC LM317T. The output from the IC is a regulated DC power and it can be varied using 10KΩ potentiometer. DC regulated power varies from 1 to 30V which is used to control the spinning rate of the spinning disk. The spinning rate varies from depending on the output of the 10KΩ potentiometer. The circuit is made up of bread board, shown in the Fig.4.

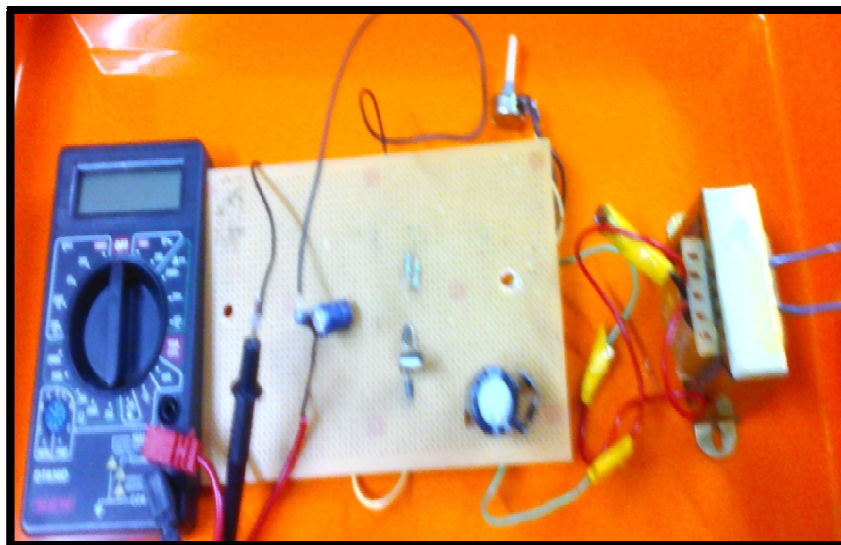

Fig.4. Photograph of the DC regulated power supply

## International Journal of Innovative Research in Science, Engineering and Technology

(An ISO 3297: 2007 Certified Organization)

Vol. 5, Issue 6, June 2016

### II.1.2 Spinning Disk and Chuck

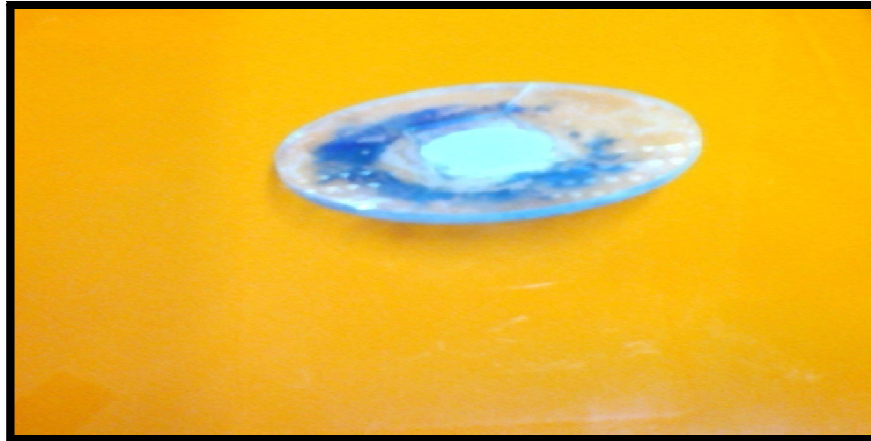

Fig.5. Spinning disk

The spinning disk of the unit is made up of acrylic sheet with thickness of 4mm and the substrate holder is grooved at the center of the spinning disk with a latch on the top edge. The substrate of the same dimension inserts at the groove and the latch is used to take the substrate as forceps. The entire arrangement is enclosed with cubic chuck to prevent the sample from dust and sprinkling of the solution. The spinning disk is connected to the axis of DC motor.

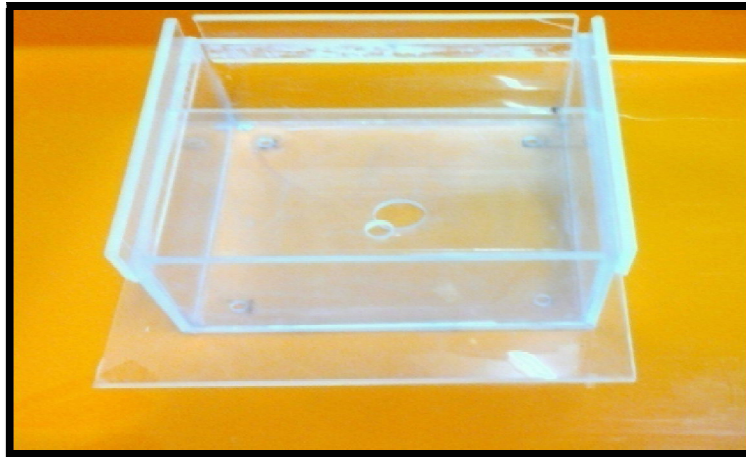

Fig.6. Acrylic Chuck

### II.2 Spin Coating Process

The process of spin coating unit is used to prepare a homogeneous thin film on a glass, silicon or metal substrate. In this process, a small quantity of the solution is introduced in the center of the substrate. The spinning disk rotates with definite spinning rate that depends on the output of the 10K $\Omega$  potentiometer and the spinning motion provides necessary centrifugal force to the small quantity of solution which is in the center of the substrate. Due to centrifugal force, the solution is evenly distributed to all sides of the substrate. Due to high speed of the spinning disk, the layer of the thin film is coated on the substrate. Due to spinning motion of the substrate, the thickness of the film depends on the spinning rate of the substrate. The thickness of the film is also influenced by the viscosity, concentration of the solution and the solvent. Fig.7 represents the schematic view of the coating process using spin coating unit and this process is used to fabricate microfilms and thickness of the film is in the nanometer range.

# International Journal of Innovative Research in Science, Engineering and Technology

(An ISO 3297: 2007 Certified Organization)

Vol. 5, Issue 6, June 2016

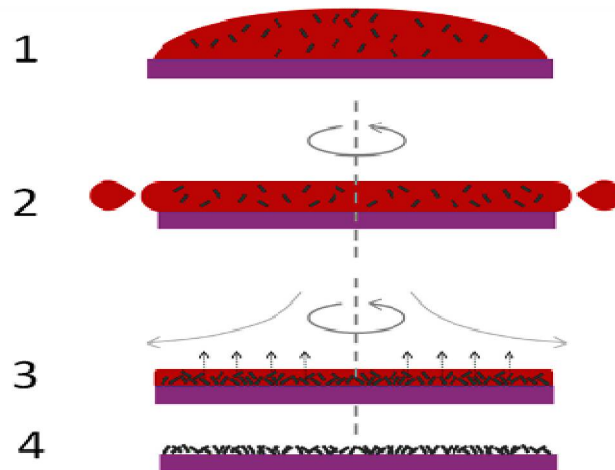

Fig.7. Schematic representation of spin coating process

### II.3 Important Steps for Spin Coater

The spin coating technique is one of the most important techniques for the preparation of uniformly coated thin films on the given substrate. The following procedures can be used to get uniformly coated thin films.

1. The viscosity of the material should be maintained at optimum range that material to be coated on the substrate seldom cohesive.
2. The injection of the coating material on the spinning substrate should be maintained exactly at the center of the substrate.
3. The revolution rate of the spinning disk should be increased gradually to avoid sprinkling of the material.
4. The spinning disk should be aligned without any shake in order to get uniformly coated material on the substrate.
5. The variation of the angular speed of the spinning disk should be as high as possible to obtain very good thin film.
6. To get uniform thin film, the spin speed and spin time is must be high.
7. The evaporation rate of the solvent should be as quick as possible.

### II.4 Evaporation Rate of Solvent

The solvent evaporation is important part in the spin coating unit and the solvent should evaporate fast at the room temperature such as acetone and toluene. The solution containing solvent and the material solute evaporate quickly from the coated material on the substrate, when they spread over the substrate. The viscosity of the solution is also maintained in the same way that does not affect the evaporation. Moreover, the film thickness depends on the evaporation of solvent, Manikandan [10].

If the solvent is not evaporating as expected, then the thickness of the film depends on the speed of the disk ( $\omega$ ) and spinning time ( $t$ ). Hence the thickness of the film related to spinning speed and spinning time as

$$d = \omega^{-1} t^{-1/2} \quad (1)$$

If the solvent evaporates with a constant rate, then

$$d = \omega^{-2/3} \quad (2)$$

In the process of spin coating, the interaction between substrate and solution layer are strongly compared than interaction between solution surface layer and air. The thickness of thin film depends on the viscosity and the concentration of coating solution. The more concentrated solution is to getting thicker thin films, the constant spinning time and varying spin speed are to obtaining thinner films or high spinning time and the constant spin speed is to getting thinner films.

## International Journal of Innovative Research in Science, Engineering and Technology

(An ISO 3297: 2007 Certified Organization)

Vol. 5, Issue 6, June 2016

### II.5 Spin Coating Thickness Equation

In general, Thickness of the thin film is inversely proportional to the square root of the spinning speed of the disk and it is given by

$$t \propto 1/\sqrt{\omega(3)}$$

The graph is drawn for the thickness of the film with respect to the spinning speed of the disk which is depicted in Fig.9. It is observed that the thickness of the film decreases exponentially with respect to the spin speed.

### III. SYNTHESSES FOR ZnO THIN FILM

ZnO thinfilm on the glass substrate is prepared by the proposed spin coating unit and analyzed. The solution is used for coating which is prepared by zinc acetate dehydrate and isopropanol stirred using magnetic stirrer at room temperature. The milky solution turns into clear homogeneous solution by adding monoethanolamine drops gradually. This solution is kept at room temperature for one day and then it is deposited on a glass substrate using spin coating unit. The substrate is dried at 200°C for 2hrs to get ZnO thinfilms.

### IV. EXPERIMENTAL RESULTS

The thickness of ZnO thinfilm depends on the spinning speed and time is confirmed by analyzing the films deposited using spin coating unit. Fig.8 shows the photograph of ZnO thinfilms on glass substrate with varying spin speed and time. From the figures, it is confirmed that a good homogeneous thin film can be prepared by the proposed spin coating unit.

ZnO films are prepared for the spinning speed of 500, 1000 and 1500 rpm. The solution is slowly introduced at the center of the substrate and examined. Fig 8-(c) is shown better results for homogeneous ZnO thin films.

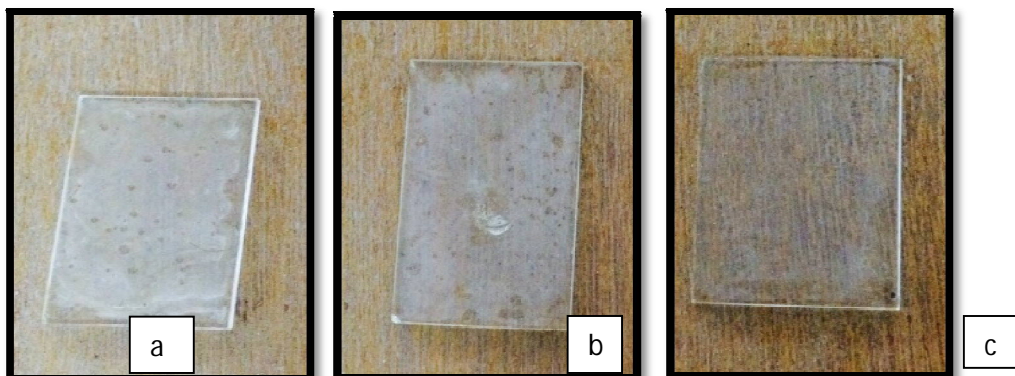

Fig.8. ZnO thinfilms for Varying spin speed with constant spin time (1 minute). The fig (a) 500 rpm (b)1000 rpm and (c) 1500 rpm with constant spin time.

# International Journal of Innovative Research in Science, Engineering and Technology

(An ISO 3297: 2007 Certified Organization)

Vol. 5, Issue 6, June 2016

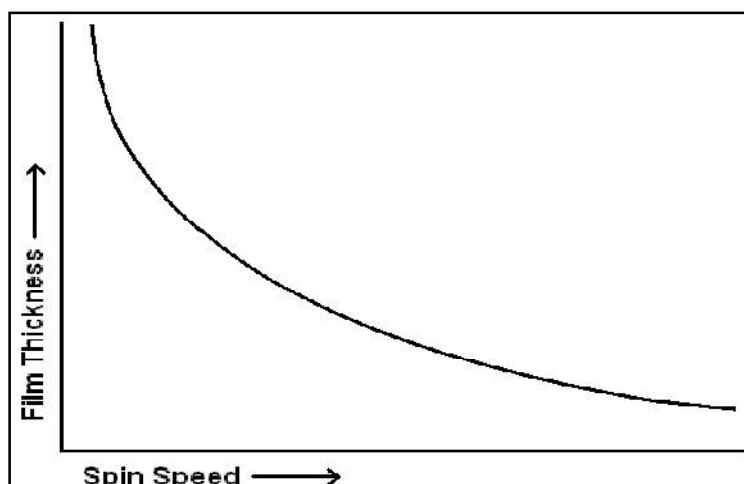

Fig.9.Variation of film thickness with respect to spin speed

## V. CONCLUSION

The construction of low cost homemade spin coating techniques has been successfully installed in the lab up to 6500 RPM. For the fabrication of the spin coating unit, DC motor, electronic components, spinning disk and cover glass have been used which are locally available. The suitability of the spin coating unit for thin film coating, ZnO films are prepared by varying the spinning speed and time. The proposed spin coating unit has its own advantage of low-cost reliable technique to coat thin films on the given substrate.

## REFERENCES

- [1] P. Sevvanthi, A. Claude, C. Jayanthi, and A. Poiyamozhi, "Instrumentation for fabricating an indigenous spin coating apparatus and growth of zinc oxide thin films and their characterizations", *Advances in Applied Science Research*, vol. 3, no.6, pp. 3573-3580, 2012.
- [2] S. Ilican, and Y. Caglar, "Preparation and characterization of ZnO thin films deposited by sol-gel spin coating method", *Journal of Optoelectronics and Advanced Materials*, vol. 10, no.10, pp. 2578 -2583, 2008.
- [3] Dietrich Meyerhofer, "Characteristics of resist films produced by spinning", *Journal of Applied Physics*, vol.49, 3993, 1978.
- [4] Mitzi DB, Kosbar LL, Murray CE, M. Copel, and A. Afzali, "High-mobility ultrathin semiconducting films prepared by spin coating", *Nature*, vol. 18, 428(6980), pp. 299-303, 2004.
- [5] M.D. Tyona, "A comprehensive study of spin coating as a thin film deposition technique and spin coating equipment", *Advances in Material Research*, Vol. 2, no.4, pp. 181-193, 2013.
- [6] Niranjansahu, B. parija, and S. panigrahi, "Fundamental understanding and modeling of spin coating process : A review", *Indian J. Phys*, 83 (4), pp. 493-502, 2009.
- [7] Mohua Fardousi, M.F. Hossain, M.S. Islam, and Sharik Rahat Ruslan, "Cost-Effective Home-Made Spin Coater for Depositing Thin Films", *Journal of Modern Science and Technology*, vol. 1, no.1, pp. 126-134, 2013.
- [8] LE. Scriven, "Physics and applications of dip coating and spin coating", *MRS proceedings*, 121
- [9] Chii-Ruey Lin, Hong-Ming Chang, Minh-Khoa Ben Dao, Hsiu-Hsien Chiang, and Wei-En Chen, "Fabrication of Antireflection Nanodiamond Particle Film by the Spin Coating Deposition Technique", *International Journal of Photo energy*, 2014
- [10] N. Manikandan, "Construction of Spin Coating Machine Controlled by Arm Processor for Physical Studies of PVA", *International Journal of Electronics and Electrical Engineering*, vol. 3, no.4, 2015.
- [11] Mohammad Meftahul Ferdous, M.M. Rashid, and Mohammad Ataur Rahman, "Design and Fabrication of a Simple Cost Effective Spin Coater for Deposition of Thin Film", *Advances in Environmental Biology*, 8(3), pp. 729-733, 2014.
- [12] Ya-Yu Huang, and Kan-Sen Chou, "Studies on the spin coating process of silica films", *Ceramics International*, 29, pp. 485-493, 2003.
- [13] P. Yimsiri, and M.R. Mackley, "Spin and dip coating of light-emitting polymer solutions: Matching experiment with modeling", *Chemical Engineering Science*, 61, pp. 3496-3505, 2006.
- [14] R. Dewi, N.I. Baa'Yah, and I.A. Talib, "The effect of spin coating rate on the microstructure, grain size, surface roughness and thickness of Ba<sub>0.6</sub>Sr<sub>0.4</sub>TiO<sub>3</sub> thin film prepared by the sol-gel process", *Materials Science-Poland*, vol. 25, no.3, 2007.