

Router 1X3 – RTL Design and Verification

Nidhi Gopal ¹

Senior Project Faculty, Department of VLSI, National Institute of Electronics and Information Technology,
Aurangabad, India¹

ABSTRACT: Routing is the process of moving a packet of data from source to destination and enables messages to pass from one computer to another and eventually reach the target machine. A router is a networking device that forwards data packets between computer networks. It is connected to two or more data lines from different networks (as opposed to a network switch, which connects data lines from one single network). This paper, mainly emphasizes upon the study of router device, its top level architecture, and how various sub-modules of router i.e. Register, FIFO, FSM and Synchronizer are synthesized, and simulated and finally connected to its top module.

KEYWORDS: Router, Routing, Verilog, Questasim, Xilinx ISE

I. INTRODUCTION

A **router** is a networking device that forwards data packets between computer networks. A router is connected to two or more data lines from different networks (as opposed to a network switch, which connects data lines from one single network). When a data packet comes in on one of the lines, the router reads the address information in the packet to determine its ultimate destination. Then, using information in its routing table or routing policy, it directs the packet to the next network on its journey. This creates an overlay internetwork. Routers perform the "traffic directing" functions on the Internet. A data packet is typically forwarded from one router to another through the networks that constitute the internetwork until it reaches its destination node.



Figure 1: Router Device: A networking Device that forward data packets.

II. THEORETICAL BACKGROUND

A router is a device that forwards data packets along networks. It is connected to at least two networks, commonly two LANs or WANs or a LAN and its ISP's network and is located at gateways, the places where two or more networks connect. It is an OSI layer 3 routing device. It drives an incoming packet to an output channel based on the address fields contained in the packet header. Routers use headers and forwarding tables to determine the best path for forwarding the packets, and they use protocols to communicate with each other and configure the best route between any two hosts.

International Journal of Innovative Research in Science, Engineering and Technology

(An ISO 3297: 2007 Certified Organization)

Vol. 5, Issue 6, June 2016

Figure below, shows top level architecture of router, which include components like FIFO, Register, synchronizer, FSM and input and output signals between them.

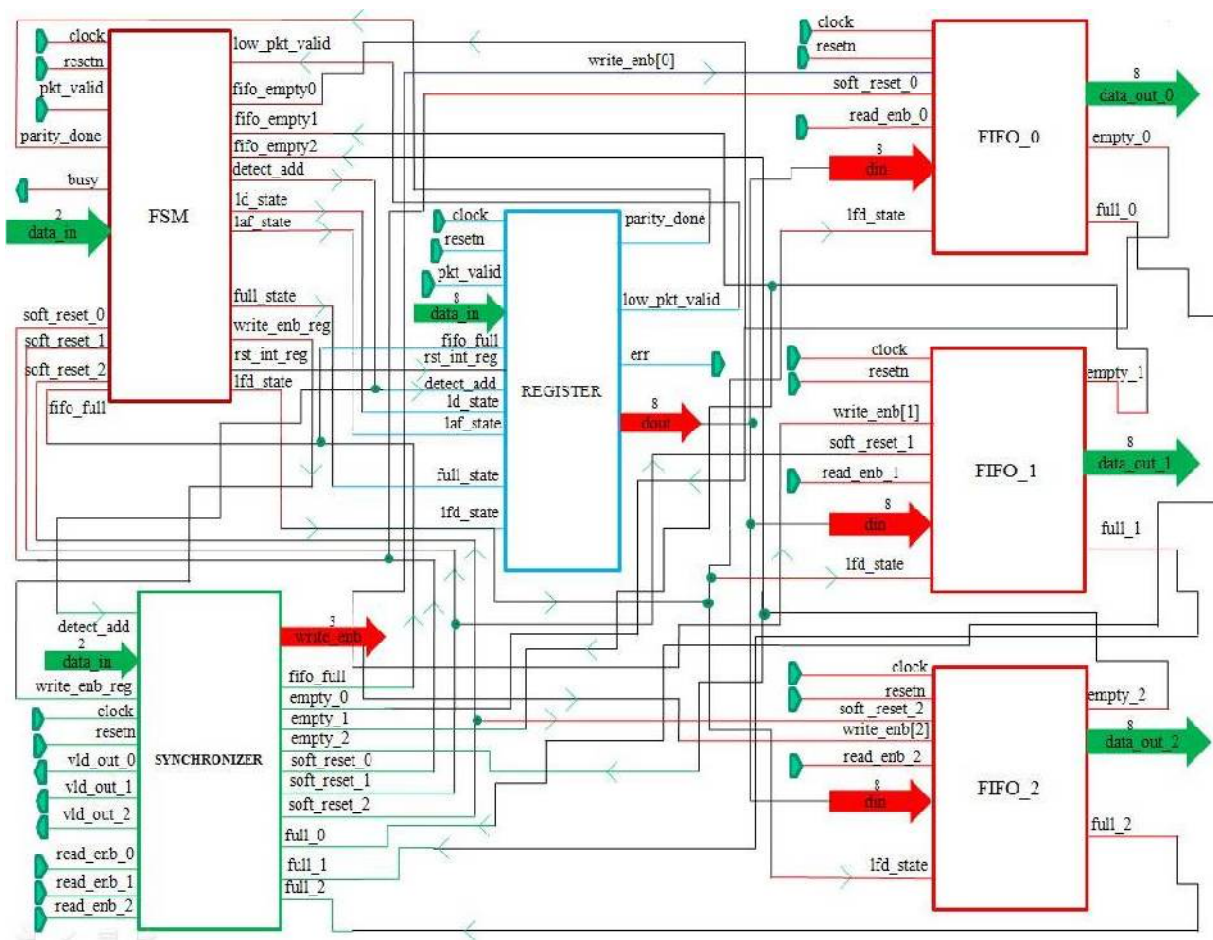

Figure 2: Top level architecture of Router

International Journal of Innovative Research in Science, Engineering and Technology

(An ISO 3297: 2007 Certified Organization)

Vol. 5, Issue 6, June 2016

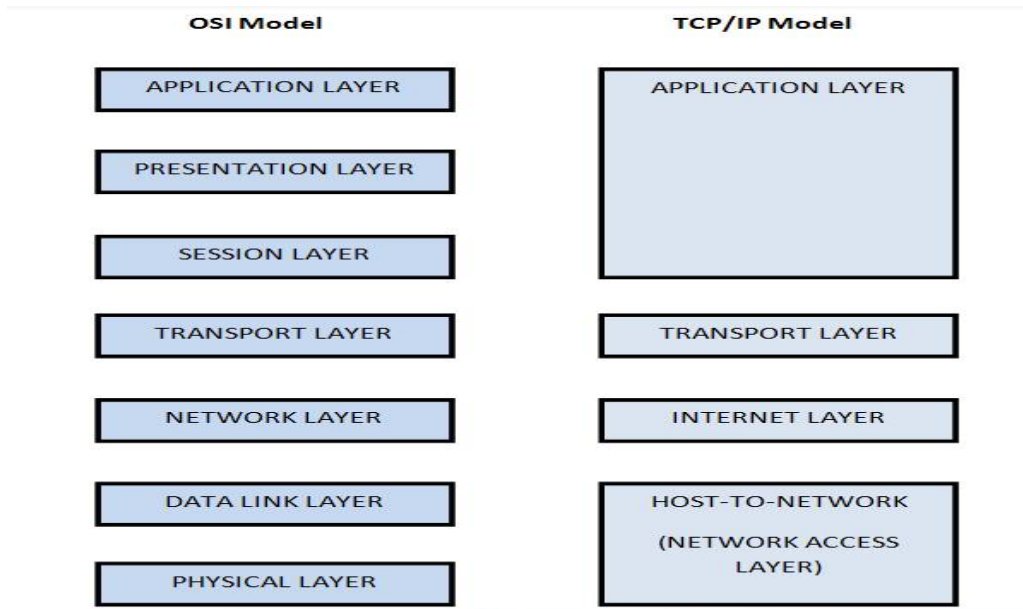

Figure 3: Diagrammatic Comparison between OSI Reference Model and TCP/IP Reference Model

1. Router packet:

Packet format: the packet consists of 3 parts: Header, payload and parity each of 8 bit width and the length of the payload can be extended between 3 between 1 byte to 63 byte.

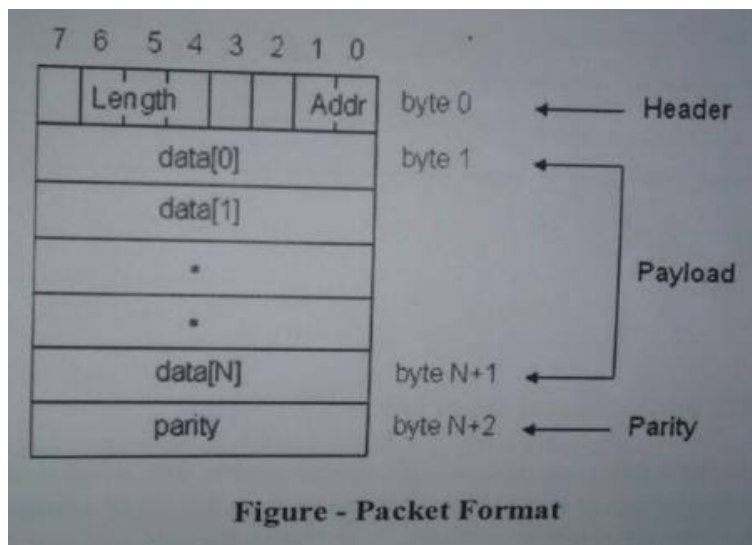

Figure 4: Packet format of a Router

- **Header:** Packet header contain two fields DA and length.
- DA: Destination Address of the packet is of 2 bits. The router drives the packet to the respective ports based on this destination address of the packets.

International Journal of Innovative Research in Science, Engineering and Technology

(An ISO 3297: 2007 Certified Organization)

Vol. 5, Issue 6, June 2016

Each output port has 2-bit unique port address. If the destination address of the packet matches the port address, then router drives the packet to the output port. The address '3' is invalid.

- Length: length of the data is of 6-bits. It specifies the number of the number of the data bytes. A packet can have a minimum data size of 1 byte and a maximum size of 63 bytes.

If length =1, it means data length is 1 byte

If length =2, it means data length is 2 bytes

If length =63, it means data length is 63 bytes

- **Payload:** payload is the data information. Data should be in terms of the bytes.
- **Parity:** This field contains the security check of the packet. It is calculated as bitwise parity over the header and payload bytes of the packet as mentioned below.

2. Router Input Protocol:

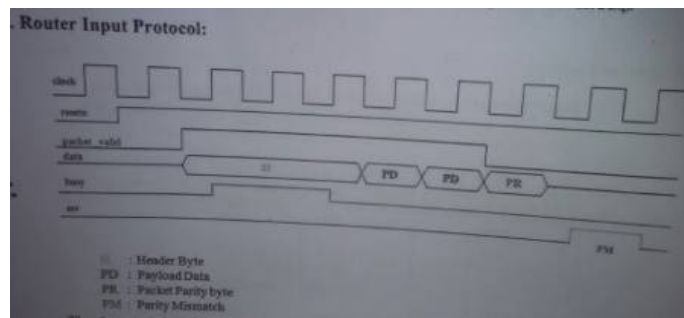

Figure 5: Router Input protocol

The characteristics of the DUT input protocols are as follows:

- Testbench Notes: All input signals are active high except low reset and are synchronized to the falling edge of the clock. This is because the DUT router is sensitive to the rising edge of the clock. Therefore, in the testbench, driving input signals on the falling edge ensures setup and hold time. But in the system Verilog/UVM based testbench, clocking block can be used to drive the signals on the positive edge of the clock itself and thus avoids metastability.
- The packet_valid signal is asserted on the same clock edge when the header byte driven onto the input data bus.
- Since the header byte contains the address, this the router to which output channel the packet should be routed to (data_out_0, data_out_1, data_out_2).
- Each subsequent byte of payload after header byte should be driven on the input data bus for every new falling edge of the clock.
- After the last payload byte has been driven, on the next falling edge of the clock, the packet_valid signal must be de-asserted, and the packet parity should be driven. This signals packet completion.
- The testbench shouldn't drive any byte when busy signal is detected instead it should hold the last driven values.
- The `busy` signal when asserted drops any incoming byte of the data.
- The "err" signal is asserted when a packet parity mismatch is detected.

3. Router Output Protocol

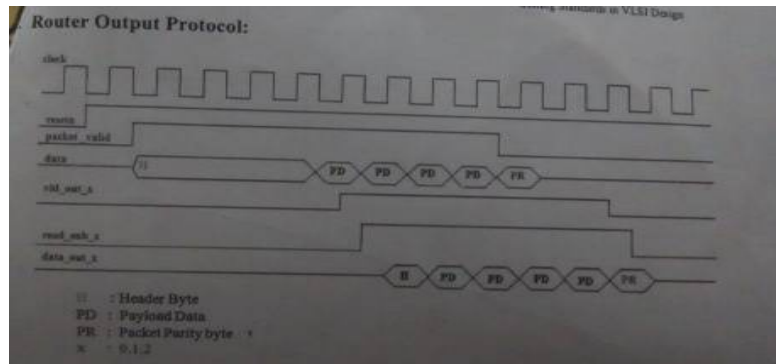

Figure 6: Router Output Protocol

The characteristics of the output protocol are as follows:

- Test bench Note: All output signals are active high and are synchronized to the rising edge of the clock.
- Each output port data_out_X (data_out_0, data_out_1, data_out_2) is internally buffered by a FIFO of size 16X9.
- The router asserts the vld_out_X (vld_out_0, vld_out_1, vld_out_2) signal when valid data appears on the vld_out_X(data_out_0,data_out_1,data_out_2) output bus. This is a signal to the receiver's client which indicates the data is available on a particular output data bus.
- The packet receiver will then wait until it has enough space to hold the bytes of the packet and then respond with the assertion of the read_enb_X(read_enb_0,read_enb_1,read_enb_2) signal.
- The read_enb_X(read_enb_0,read_enb_1 or read_enb_2) input signal can be asserted on the falling clock edge in which data are read from the data_out_X(data_out_0,data_out_1,data_out_2)bus.
- The read_enb_X(read_enb_0,read_out_1 or read_out_2) must be asserted within 30 clock cycles of the vld_out_X(vld_out_0,vld_out_1,vld_out_2) being asserted else time-out occurs, which resets the FIFO.
- The data_out_X (data_out_0,data_out_1 or data_out_2) bus will be tri-stated(high Z) during a scenario when a packet's header byte is lost due to time-out condition .

4. Router- Top Level block

The top level architecture of router is shown in the figure. The router module consists of FSM, REGISTER, SYNCHRONIZER, FIFO_0, FIFO_1, FIFO_2.

During the course of the designing and implementing the whole module, we design each sub-module one by one individually using RTL coding in Verilog and then from the top we will instantiate all sub-module using structural style of modeling and using some constructs of advance Verilog also.

5. Router : FIFO

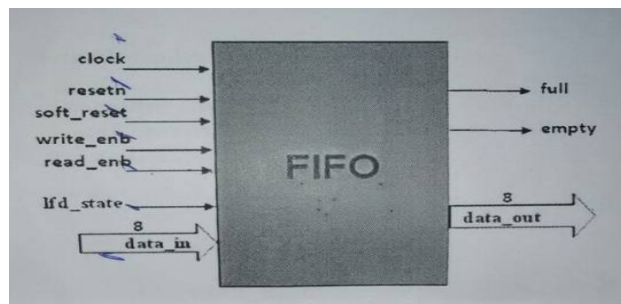

Figure 6: Router FIFO

International Journal of Innovative Research in Science, Engineering and Technology

(An ISO 3297: 2007 Certified Organization)

Vol. 5, Issue 6, June 2016

Functionality

There are 3 FIFOs used in the router design. Each FIFO is of 9 bits wide and 16 bit bytes depth. The FIFO works on the system clock and is reset with a synchronizer active low reset. The FIFO is also internally reset by an internal reset signal **soft_reset**. **Soft_reset** is an active high signal which is generated by the SYNCHRONIZER block during time out state of the ROUTER.

If **resetrn** is low then **full=0**, **empty=1** and **data_out=0**.

The FIFO m/m size is 16X9. The extra bit in the data width is appended in order to detect the header byte. **Lfd_state** detects the header byte of a packet.

The 9th bit is 1 for header byte and 0 for the remaining bytes.

Write Operation:

- Signal **data_in** is sampled at the rising edge of the edge of the clock when **write_enb** is high.
- Write operation only takes place when FIFO is not full in order to avoid over_run condition.

Read operation:

- The data is read from **data_out** at rising edge of the clock, when **read_enb** is high.
- Read operation only takes place when the FIFO is not empty in order to avoid under run condition.
- During the read operation when a header byte is read, an internal counter is loaded with the payload length of the packet plus '1' (parity byte) and starts decrementing every clock till it reached 0. The counter holds 0 till it is reloaded back with a new packet payload length.
- During the time out condition, **full=0**, **empty=1**.
- **data out** is driven to HIGH impedance state under 2 scenarios:
 - When the fifo m/m is read completely (header+payload+parity).
 - Under the time out condition of the Router.
- **Full**- FIFO status which indicates that all the locations inside FIFO have been written.
- **Empty**- FIFO status which indicates that all the locations of the FIFO have been read and made empty.
- Read and write operation can be done simultaneously.

6. Router : SYNCHRONIZER

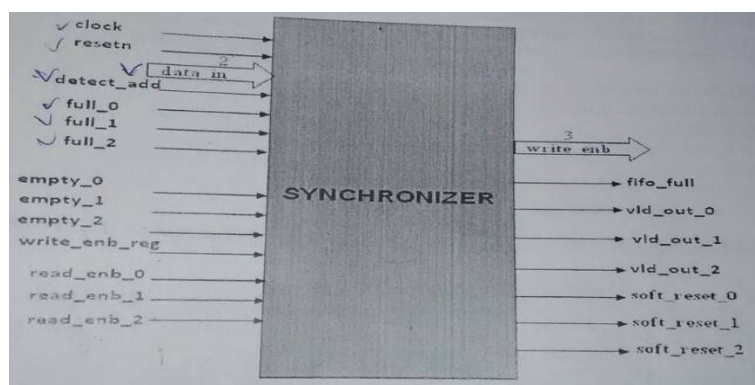

Figure 7: Router Synchronizer

Functionality:

This module provides synchronization between router FSM and router FIFO modules. It provides faithful communication between the single input port and three output ports.

- **detect_add** and **data_in** signals are used to select a FIFO till a packet routing is over for the selected FIFO.
- Signal **fifo_full** signal is asserted based on full_status of **fifo_0** or **FIFO_1** or **FIFO_2**.
- If **data_in = 2'b00** then **fifo_full=full_0**

International Journal of Innovative Research in Science, Engineering and Technology

(An ISO 3297: 2007 Certified Organization)

Vol. 5, Issue 6, June 2016

- If **data_in=2'b01** then **fifo_full=full_1**
- If **data_in=2'b10** then **fifo_full=full_2** else **fifo_full=0**
- The signal **vld_out_x** signal is generated based on empty status of the FIFO as shown below :
 - **vld_out_0=~empty_0**
 - **vld_out_1=~empty_1**
 - **vld_out_2=~empty_2**
- The **write_enb_reg** signal is used to generate **write_enb** signal for the write operation of the selected FIFO.
- There are 3 internal reset signals (**soft_reset_0, soft_reset_1, soft_reset_2**) for each of the FIFO respectively. The respective internal reset signals goes high if **read_enb_X (read_enb_0,read_out_1,read_out_2)** is not asserted within 30 clock cycles of the **vld_out_X(vld_out_0,vld_out_1 or vld_out_2)** being asserted respectively.

7. Router : FSM

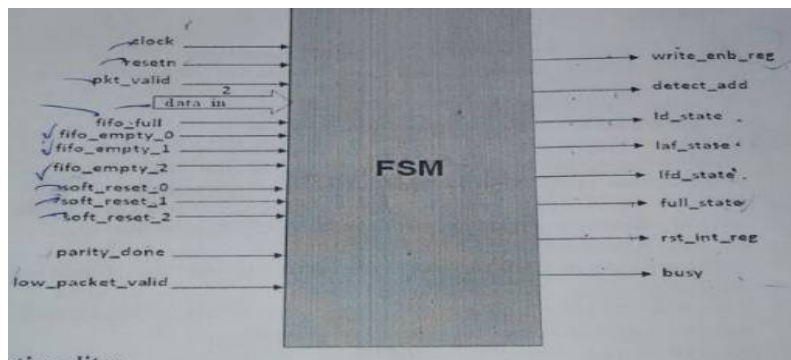

Figure 8: Router FSM

STATE-DECODE_ADDRESS

- This is the initial reset state.
- Signal **detect_add** is asserted in this state which is used to detect an incoming packet. It is also used to latch the first byte as a header byte.

STATE-LOAD_FIRST_DATA

- Signal **lfd_state** is asserted in this state which is used to load the first data byte to the FIFO.
- Signal **busy** is also asserted in this state so that header byte that is already latched doesn't update to a new value for the current packet.
- This state is changed to LAOD_DATA state unconditionally in the next clock cycle.

STATE-LOAD_DATA

- In this state the signal **ld_state** is asserted which is used to load the payload data to the FIFO.
- Signal **busy** is de asserted in this state, so that ROUTER can receive the new data from input source every clock cycle,
- Signal **write_enb_reg** is asserted in this state in order to write the Packet information(Header+Payload+Parity) to the selected FIFO.
- This state transits to LAOD_PARITY state when **pkt_valid** goes low and to FIFO_FULL_STATE when FIFO is full.

STATE-LOAD_PARITY

- In this state the last byte is latched which is the parity byte.
- It goes unconditionally to the state CHECK_PARITY_ERROR.
- Signal **busy** is asserted so that ROUTER doesn't accepts any new data.
- **write_enb_reg** is made high for latching the parity byte to FIFO.

International Journal of Innovative Research in Science, Engineering and Technology

(An ISO 3297: 2007 Certified Organization)

Vol. 5, Issue 6, June 2016

STATE-FIFO_FULL_STATE

- busy signal is made high and write_enb_reg signal is made low.
- Signal full_state is asserted which detects the FIFO full state.

STATE-LOAD_AFTER_FULL

- In this state laf_state signal is asserted which is used to latch the data after FIFO_FULL_STATE.
- Signal busy & write_enb_reg is asserted.
- It checks for parity_done signal and if it is high, shows that LOAD_PARITY state has been detected and it goes to the state DECODE_ADDRESS.
- If low_packet_valid is high it goes to LOAD_PARITY state otherwise it goes back to the LOAD_DATA state.

STATE-WAIT_TILL_EMPTY

- Busy signal is made high and write_enb_reg signal is made low.

STATE-CHECK_PARITY_ERROR

- In this state rst_int_reg signal is generated, which is used to reset low_packet_valid signal.
- This state changes to DECODE_ADDRESS when FIFO is not full and to FIFO_FULL_STATE when FIFO is full.
- Busy is asserted in this state.

8. ROUTER: Register

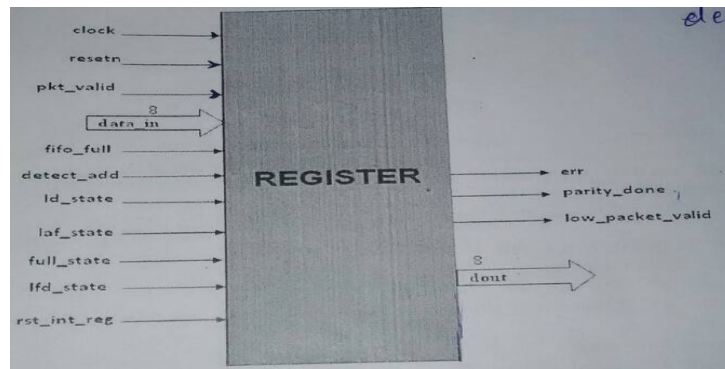

Figure 9: Router : Register

Functionality:

This module implements 4 internal registers in order to hold a header byte, FIFO full state byte, internal parity and packet parity byte. All the registers in this module are latched on the rising edge of the **clock**.

- If **resetn** is low then the signals (**dout**, **err**, **parity_done** and **low_pkt_valid**) are low.
- The signal **parity_done** is high under the following conditions:
 - When signal **ld_state** is high and signals (**fifo_full** and **pkt_valid**) are low.
 - When signals **laf_state** and **low_pkt_valid** both are high and the previous value of **parity_done** is low.
- **rst_int_reg** signal is used to reset **low_pkt_valid** signal.
- **detect_add** signal is used to reset **parity_done** signal.
- Signal **low_pkt_valid** is high when **ld_state** is high and **pkt_valid** is low. **Low_packet_valid** shows that **pkt_valid** for current state has been deasserted.
- First data byte i.e., header is latched inside an internal register when **detect_add** and **pkt_valid** signals are high. This data is latched to the output **dout** when **lfd_state** goes high.
- Then signal **data_in** i.e. Payload is latched to **dout** if **ld_state** signal is high and **fifo_full** is low.

International Journal of Innovative Research in Science, Engineering and Technology

(An ISO 3297: 2007 Certified Organization)

Vol. 5, Issue 6, June 2016

- Signal **data_in** is latched to an internal register when **ld_state** and **fifo_full** are high. This data is latched to output **dout** when **laf_state** goes high.
- **Full_state** is used to calculate internal parity.
- Another internal register is used to store internal parity for parity matching. Internal parity is calculated using the bit-wise xor operation between header byte, payload byte and previous parity values as shown below:

$$\text{parity_reg} = \text{parity_reg_previous} \oplus \text{header_byte} \text{ ---- } t1 \text{ clock cycle}$$

$$\text{parity_reg} = \text{parity_reg_previous} \oplus \text{header_byte} \text{ ---- } t1 \text{ clock cycle}$$

$$\text{parity_reg} = \text{parity_reg_previous} \oplus \text{header_byte} \text{ ---- } t1 \text{ clock cycle}$$

$$\text{parity_reg} = \text{parity_reg_previous} \oplus \text{header_byte} \text{ ---- } t1 \text{ clock cycle}$$
- **Last payload byte**
- The **err** is calculated only after packet parity is loaded and goes high if the packet parity doesn't match with the internal parity.

III. SIMULATION RESULTS

Following components of router were synthesized and simulated, using Xilinx ISE software. And Simulation results were observed. Following are the results obtained:

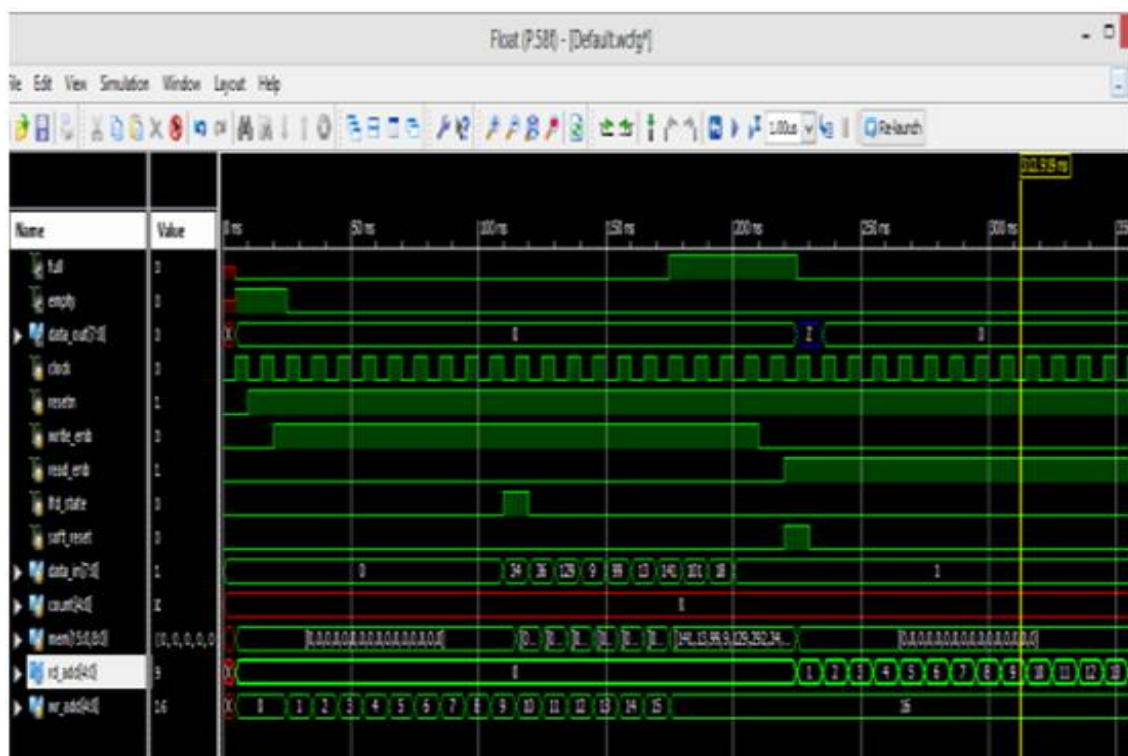

Figure 10 : Fifo output

International Journal of Innovative Research in Science, Engineering and Technology

(An ISO 3297: 2007 Certified Organization)

Vol. 5, Issue 6, June 2016

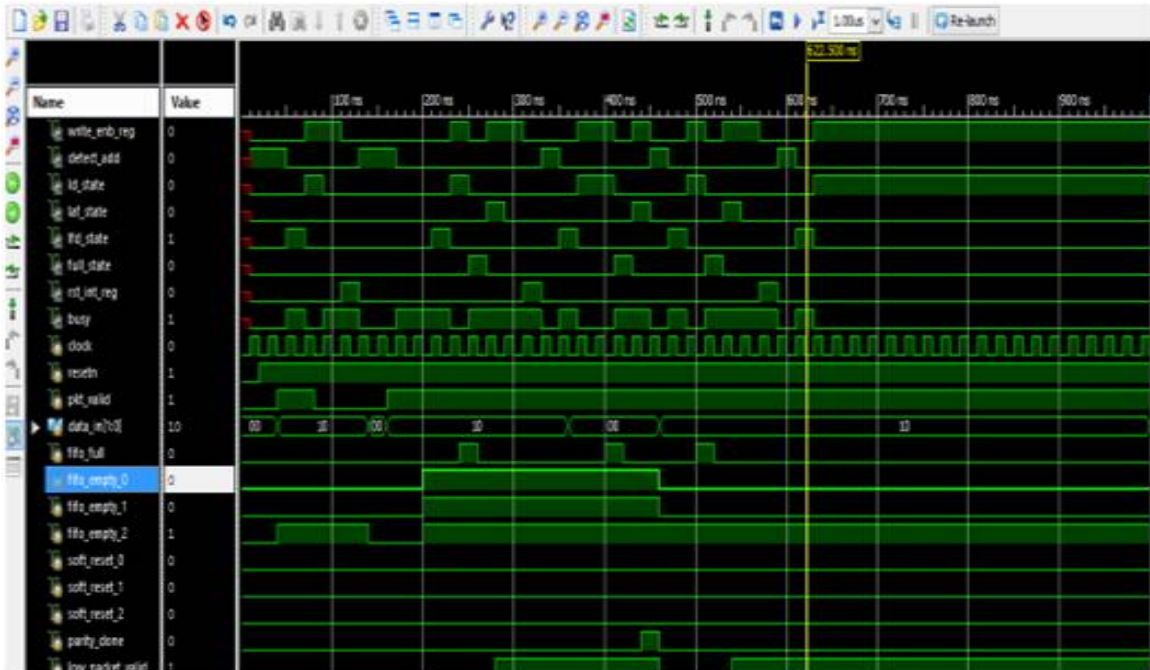

Figure 11 : Fsm output



Figure 12: Synchronizer output

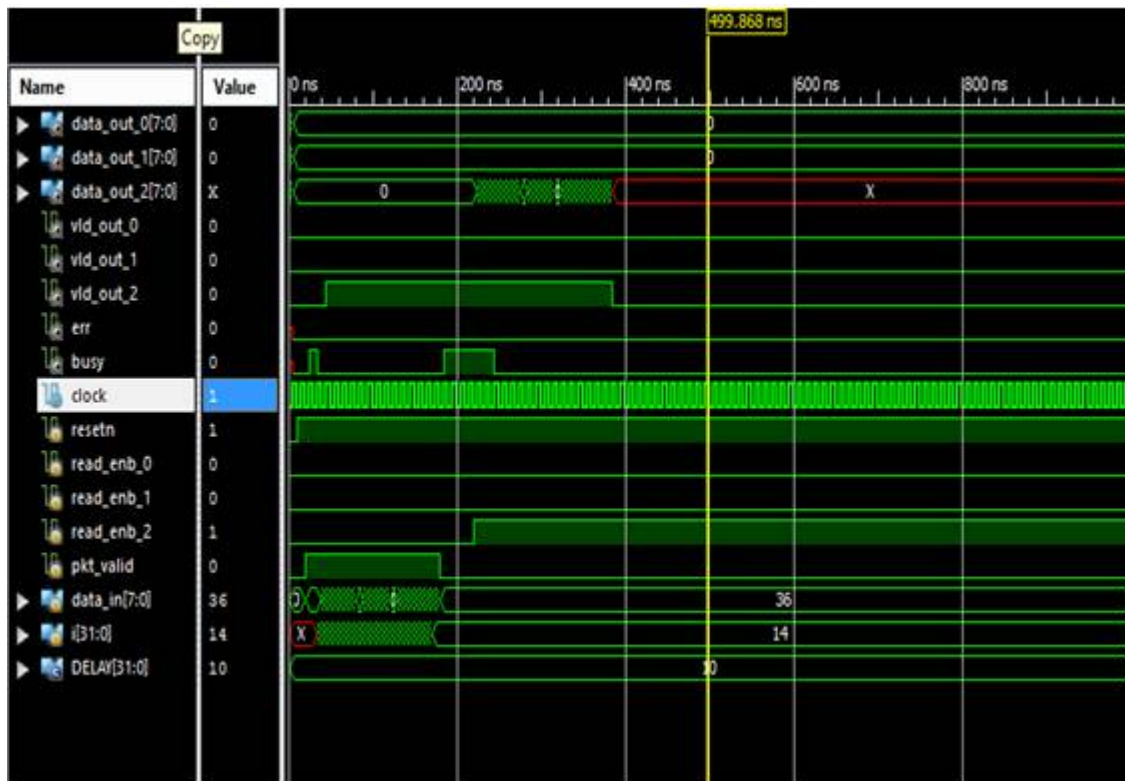

Figure 13: Top output

IV. CONCLUSION

The Router1X3 is designed and verified successfully. Many coding bugs are debugged during the verification.

Scenarios like packets with payload length

- 8 byte
- 14 byte
- 16 byte
- 17 byte
- FIFO full state(observing busy signal)
- Good packet
- Packet which is never read
- Simultaneous read write operation
- Bad packet/corrupt packet

were driven from the testbench to determine the robustness of the design. And it was working seamlessly as shown by the coverage report produced by Questasim with 100% FSM state coverage, 81.81% FSM transition coverage, 96.42% toggle coverage, 92.40% statement coverage.

International Journal of Innovative Research in Science, Engineering and Technology

(An ISO 3297: 2007 Certified Organization)

Vol. 5, Issue 6, June 2016

Figure 7: Coverage Summary: By structure, by type

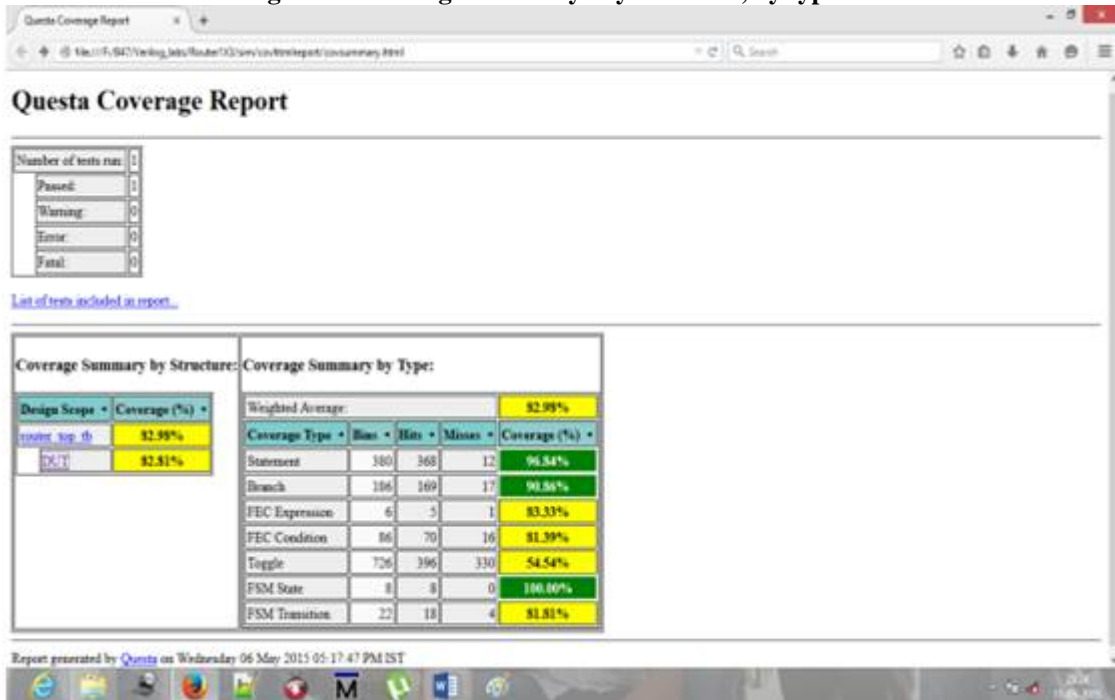

Figure 14: Coverage report by instance

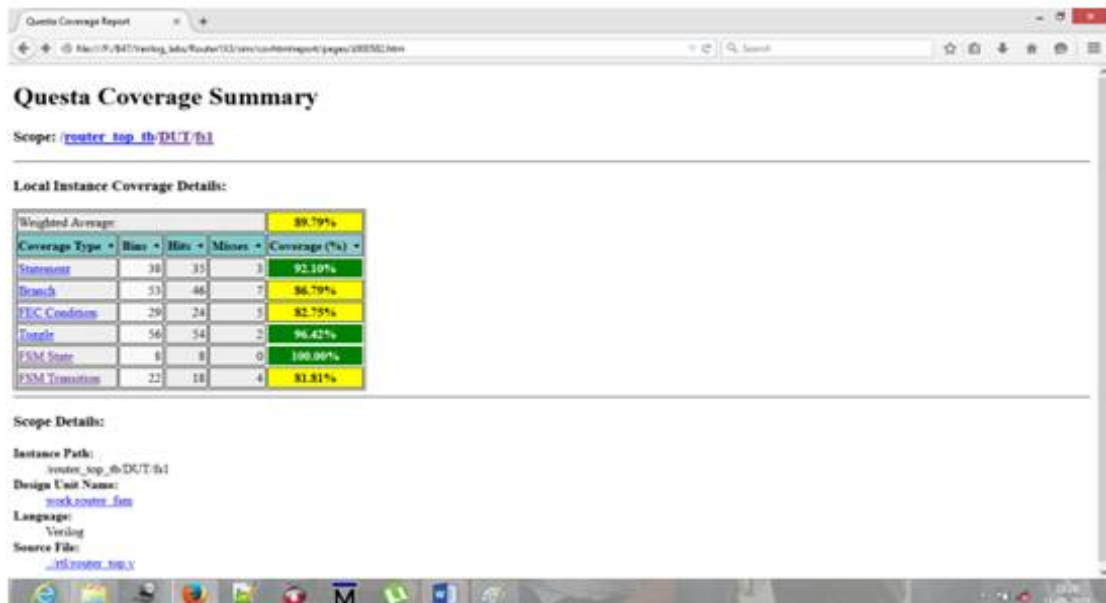

Figure 15 : Coverage Report

International Journal of Innovative Research in Science, Engineering and Technology

(An ISO 3297: 2007 Certified Organization)

Vol. 5, Issue 6, June 2016

V. ACKNOWLEDGEMENT

The author would like to thank Mrs. Susmita Nayak, and Mr. Putta Satish , Faculty of VLSI , Maven Silicon Institute, for their time –to-time and proper guidance, continuous support and engagement in this research.

REFERENCES

- [1]. Verilog HDL:- Samir Palnitkar
- [2]. System Verilog:- Chris Spear
- [3]. The ASIC Website: www.asicworld.com
- [4]. www.google.com/fifo-theory-verilog
- [5]. www.wikipedia.com
- [6]. Liang Qin, Thomas Kunz , “Adaptive MANET Routing: A case study” Springer:, Vol 5198, pp 43-57.
- [7]. Clausen Ed., T., Jacquet, P.” Optimized link State Routing Protocol (OSLR)” , RFC 3626
- [8]. Johnson, D.B., et al.: “DSP: The Dynamic Source Routing Protocol for Multi Hop Wireless Ad Hoc Network”. In: Perkins, C.E.(ed.) Ad Hoc Networking , ch. 5, pp 139-172. Addison –Wesley, Reading(2001).

BIOGRAPHY



The author, Nidhi Gopal, did her BTech in Electronics and Communication and Mtech in VLSI from Jayoti Vidyapeeth Women’s University, Jaipur, Rajasthan, India. She is presently working with National Institute of Electronics and Information Technology, Aurangabad as a Senior Project Faculty.

[1]