

# Design Optimization and Stress Analysis of Multicylinder Diesel Engine Crankshaft

Mallikarjuna Naraga<sup>1</sup>, Babu Uppalapati<sup>2</sup>

P.G. Student, Annamacharya Institute of Technology and Sciences (AITS), Tirupathi, A.P, India<sup>1</sup>

Assistant Professor, Department of Mechanical Engineering, AITS, Tirupathi, A.P, India<sup>2</sup>

**ABSTRACT:** For every Internal combustion engine crank shaft plays the most important role in power transmission and one of the complicated components for effective and precise working of internal combustion engine, here the impact load will be applied on the crank shaft which leads to bend or crack the crank shaft. This can be reduced with the design modification. This paper involves in Design and Analysis of multi cylinder diesel engine crank shaft. Design of the crankshaft was done with the help of CATIA V5 R15 design software and the analysis was done with ANSYS software. The stress analysis of a 4-cylinder crankshaft are discussed using finite element method before and after modification in this paper Maximum stress areas and dangerous areas are found by the stress analysis of crankshaft and Deformation of the crank shaft for different materials. The Analysis was done before and after modification at stress concentrated areas with different loads by that the comparison was taken place. In the stress analysis we get the maximum stress values before and after modification. All the obtained values were plotted. Modifications are applied to reduce the stress of the crankshaft and by that the comparison was done with the previous design. By this the appropriate design optimization will be achieved.

**KEYWORDS:** Crankshaft,CATIA V5,ANSYS Workbench,FEM,Structuralsteel,Gray cast iron,Copper alloy

## I. INTRODUCTION

A crankshaft contains two or more centrally-located coaxial cylindrical ("main") journals and one or more offset cylindrical crankpin ("rod") journals. The two-plane V8 crankshaft has five main journals and four rod journals as shown in figure 1, each spaced 90° from its neighbors.

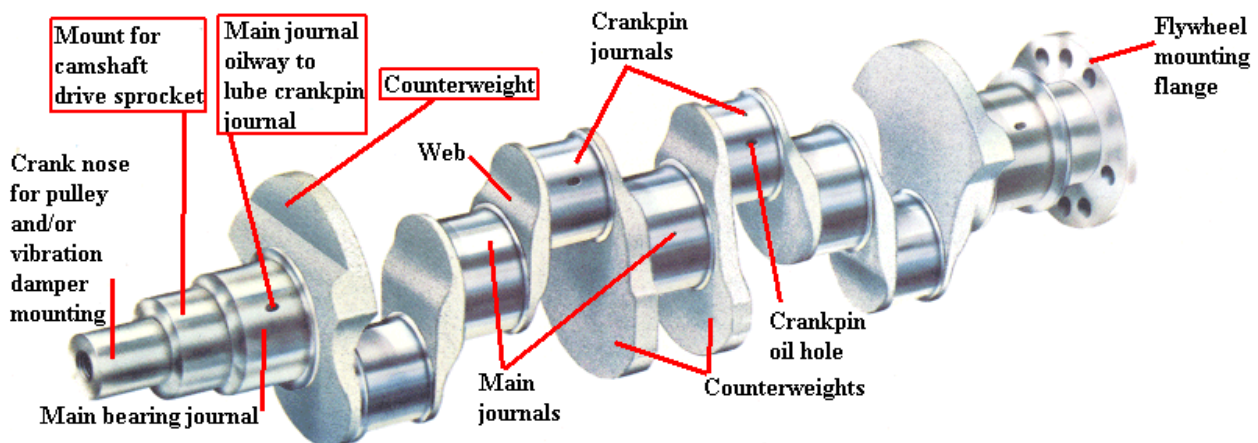

Figure: 1 Main parts of a crankshaft

# International Journal of Innovative Research in Science, Engineering and Technology

(An ISO 3297: 2007 Certified Organization)

Vol. 5, Issue 6, June 2016

The crankshaft main journals rotate in a set of supporting bearings ("main bearings"), causing the offset rod journals to rotate in a circular path around the main journal centers, the diameter of which is twice the offset of the rod journals. The diameter of that path is the engine "stroke": the distance the piston moves up and down in its cylinder. The big ends of the connecting rods ("conrods") contain bearings ("rod bearings") which ride on the offset rod journals. (For details on the operation of crankshaft bearings, For important details on the motion which the crankshaft imparts to the piston assembly.

Solanki et al. 1 presented literature review on crankshaft design and optimization. The materials, manufacturing process, failure analysis, design consideration etc. were reviewed. The design of the crankshaft considers the dynamic loading and the optimization can lead to a shaft diameter satisfying there quirements of the automobile specifications with cost and size effectiveness. They concluded that crack grows faster on the free surface while the central part of the crack front becomes straighter. Fatigue is the dominant mechanism of failure of the crankshaft. Residual imbalances along the length of the crankshafts are crucial to performance.

GuYingkui, Zhou Zhibo. 2 have been discussed a three-Dimensional model of a diesel engine crankshaft created by using PRO/E software and analytical ANSYS Software tool, it shows that the high stress region mainly concentrates in the knuckles of the crank arm & the main journal and the crank arm & connecting rod journal ,which is the area most easily broken.

Abhishekchoubey, and JaminBrahmbhatt. 3 have been analyzed crankshaft model and 3-dimentional model of the crankshaft were created by SOLID WORKS Software and imported to ANSYS software. The crankshaft maximum deformation appears at the centre of crankpin neck surface. The maximum stress appears at the fillets between the crankshaft journals and crank cheeks and near the central point journal. The edge of main journal is high stress area.

R. J. Deshbhatar, and Y.R. Suple. 4 have been analyzed 4- cylinder crankshaft and model of the crankshaft were created by Pro/E Software and then imported to ANSYS software The maximum deformation appears at the centre of crankshaft surface. The maximum stress appears at the fillets between the crankshaft journal and crank cheeks, and near the central point. The edge of main journal is high stress area. The crankshaft deformation was mainly bending deformation under the lower frequency. And the maximum deformation was located at the link between main bearing journal and crankpin and crank cheeks.

An extensive literature review on crankshafts was performed by Zoroufi and Fatemi (2005). 5 Their study presents a literature survey focused on fatigue performance evaluation and comparisons of forged steel and ductile cast iron crankshafts. In their study, crankshaft specifications, operation conditions, and various failure sources are discussed. The common crankshaft material and manufacturing process technologies in use were compared with regards to their durability performance. In their literature review, geometry optimization of crankshafts, cost analysis and potential cost saving opportunities are also briefly discussed.

Guangming and Zhengfeng. 6 performed study on torsional stiffness of engine crankshaft. Modified Ker Wilson formula and Carter formula were employed to calculate torsional stiffness of engine crankthrow in the case of different thickness and width of both sides of crankthrow. Furthermore, the finite element modals of crank and free part of crankshaft linked to torsional dynamic models were developed. Then the intrinsic torsional vibration frequency of crank and free part of crankshaft are carried out by finite element method. According to mechanics of materials and empirical formula, a theoretical calculation formula of crank torsional stiffness is proposed in the conditions of the thickness and width on both sides of crankthrow are different. By calculation and comparative analysis of an real crankshaft example to verify the finite element analysis method and finite element model is feasible.

Meng et al. 7 discussed the stress analysis and modal analysis of a 4 cylinder crankshaft. FEM software ANSYS was used to analyze the vibration modal and distortion and stress status of crank throw. The relationship between frequency and the vibration modal was explained by the modal analysis of crankshaft. This provides a valuable theoretical foundation for the optimization and improvement of engine design. Maximum deformation appears at the center of the crankpin neck surface. The maximum stress appears at the fillet between the crankshaft journal andcrank cheeks, and near the central point journal. The crankshaft deformation was mainly bending deformation was mainly bending deformation under the lower frequency. Maximum deformation was located at the link between main bearing journal and crankpin and crank cheeks. So, the area prone to appear the bending fatigue crack.

Xiaorong Zhou et al 8 described the stress concentration in static analysis of the crankshaft model. The stress concentration is mainly occurred in the fillet of spindle neck and the stress of the crankpin fillet is also relatively large.

# International Journal of Innovative Research in Science, Engineering and Technology

(An ISO 3297: 2007 Certified Organization)

Vol. 5, Issue 6, June 2016

Based on the stress analysis, calculating the fatigue strength of the crankshaft will be able to achieve the design requirements.

## II. OBJECTIVES

- i. To create the model crankshaft by using CATIA V5 software
- ii. To mesh the model crankshaft by meshing step in ANSYS WORKBENCH
- iii. Static analysis by using ANSYS WORKBENCH

## III. MODELLING

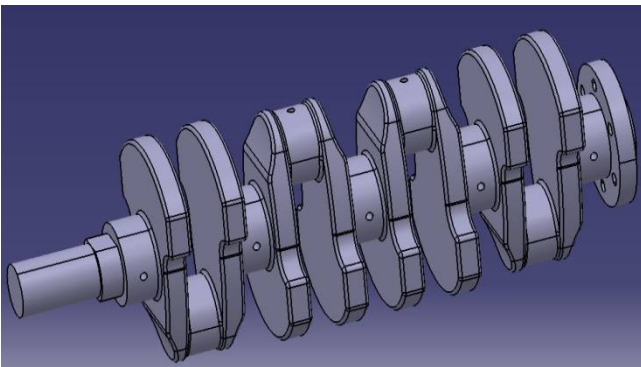

Figure: 2 CATIA model of crankshaft

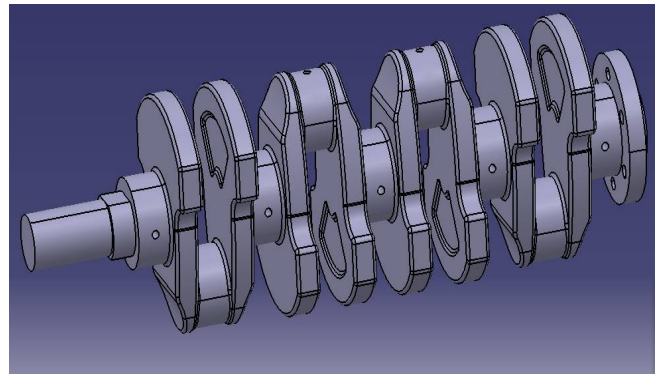

Figure:3 CATIA optimized model of crankshaft

The figure 2 shows the model of the crankshaft of multi cylinder crankshaft and the figure 3 shows the optimized model of the crankshaft designed in CATIA V5 software.

## IV. ANALYSIS RESULTS

ANSYS is general-purpose Finite Element Analysis (FEA) software package. Finite Element Analysis is a numerical method of deconstructing a complex system into very small pieces (of user designed size) called elements and this is known as meshing shown in figure 4. The software implements equations that govern the behaviour of these elements and solves them all; creating a comprehensive explanation of how the system acts as a whole. The ANSYS Workbench environment is an intuitive up-front finite element analysis tool that is used in conjunction with CAD systems and/or Design Model. ANSYS Workbench is a software environment for performing structural, thermal, and electromagnetic analyses. The Workbench focuses on attaching existing geometry, setting up the finite element model, solving, and

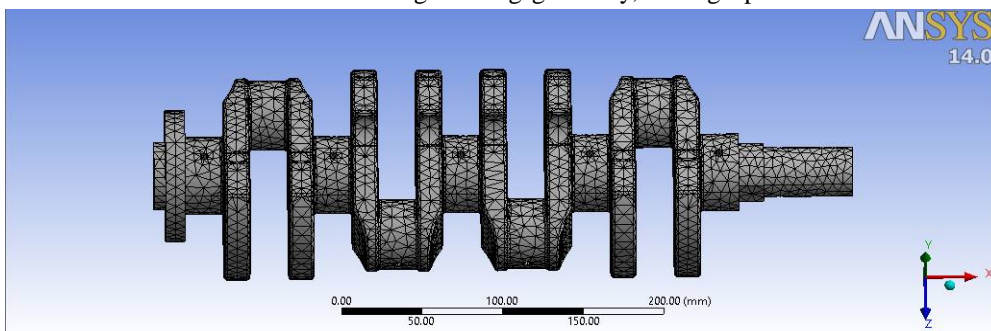
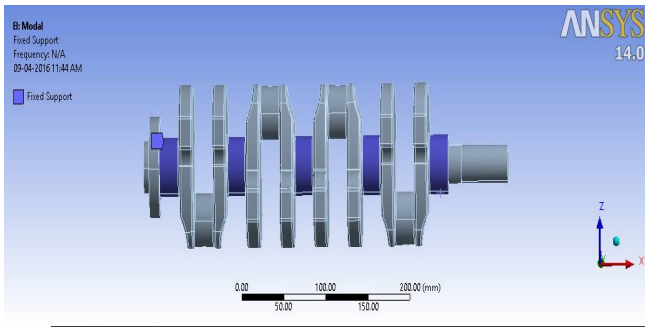
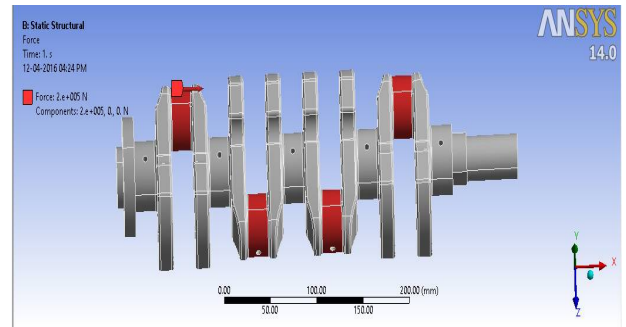

Figure: 4 meshed geometry of the model

reviewing results.



**Figure: 5 fixed support**



**Figure: 6 Applying Force and boundary conditions**

The figure 5 shows the fixed support for the model and the figure 6 will shows the where the forces we are applied and this applying force is known as boundary conditions.

**STATIC ANALYSIS FOR STRUCTURAL STEEL AT 2000N AND 3500N:**

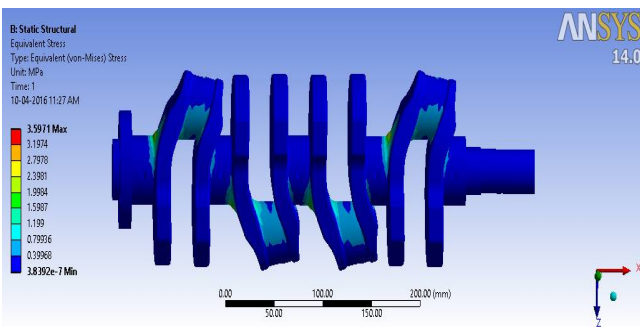

**Figure: 7 Equivalent stress-before modification**

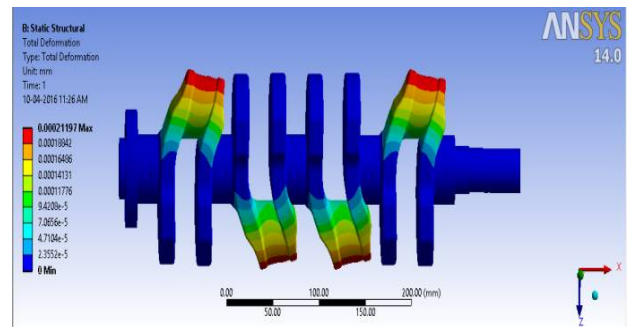

**Figure: 8 Total deformation-before modification**

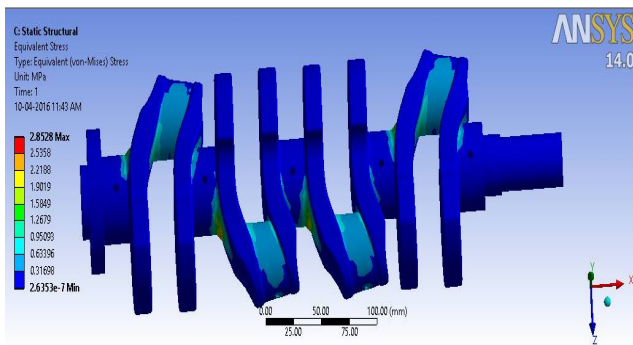

**Figure: 9 Equivalent stress-after modification**

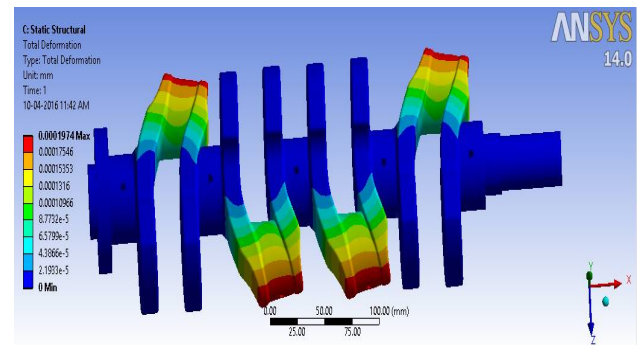

**Figure: 10 Total deformation-after modification**

The figure 7 and9 shows equivalent stress of the model before and after modification at 2000N for the material structural steel .And the fig 8 and 10 shows the Total deformation of the model before and after modification of the model crankshaft. The stress and deformation are less at after modification of the model compared from before modification of the model.

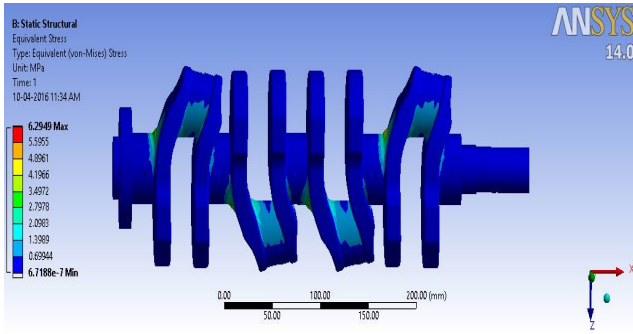

Figure: 11 Equivalent stress-before modification

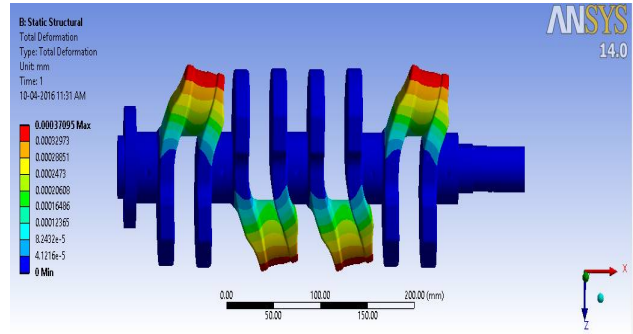

Figure: 12 Total deformation-before modification

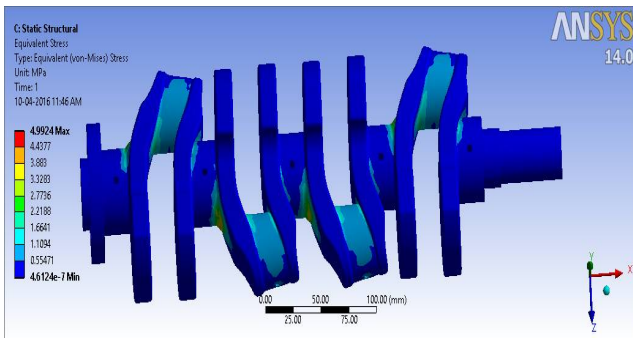

Figure: 13 Equivalent stress-after modification

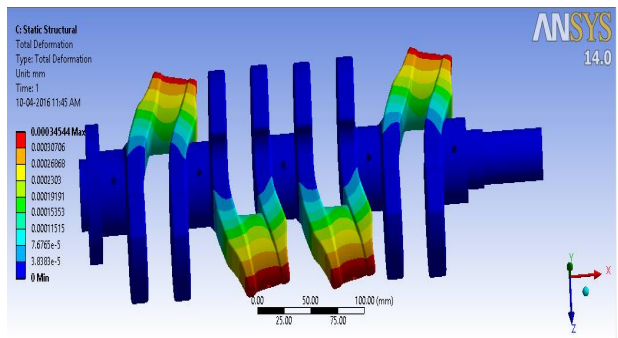

Figure: 14 Total deformation-after modification

The figure 11 and 13 shows equivalent stress of the model before and after modification at 3500N for the material structural steel .And the figure 12 and 14 shows the Total deformation of the model before and after modification of the model crankshaft. The stress and deformation are less at after modification of the model compared from before modification of the model.

**STATIC ANALYSIS FOR GRAY CAST IRON AT 2000N AND 3500N:**

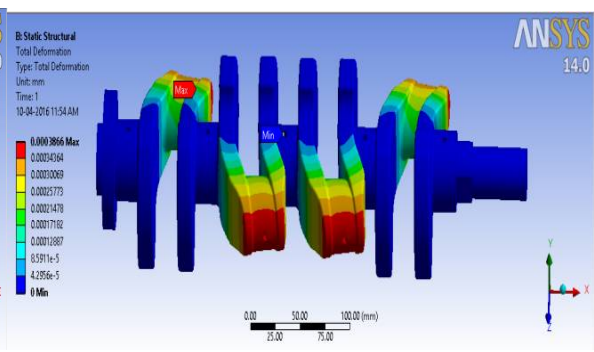
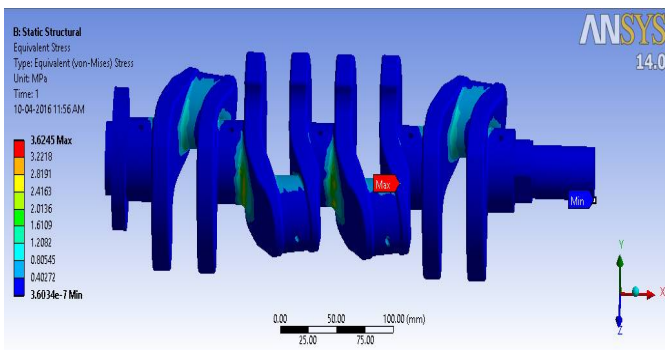

Figure: 15 Equivalent stress-before modification Figure: 16 Total deformation-after modification

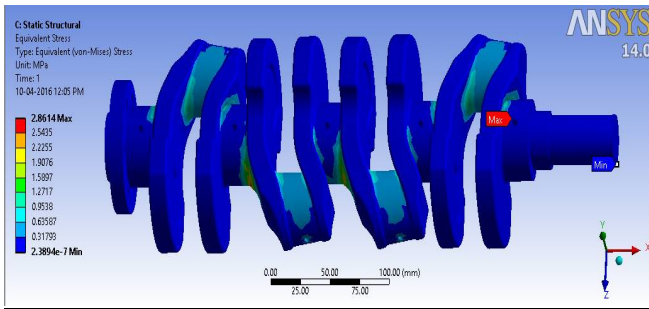

Figure: 17 Equivalent stress-after modification

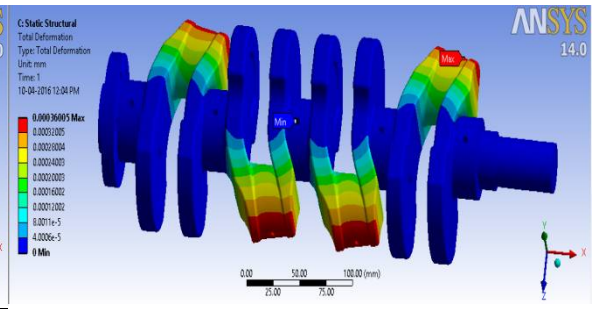

Figure: 18 Total deformation-after modification

The figure 15 and 17 shows equivalent stress of the model before and after modification at 2000N for the material Gray cast iron .And the figure 16 and 18 shows the Total deformation of the model before and after modification of the model crankshaft. The stress and deformation are less at after modification of the model compared from before modification of the model.

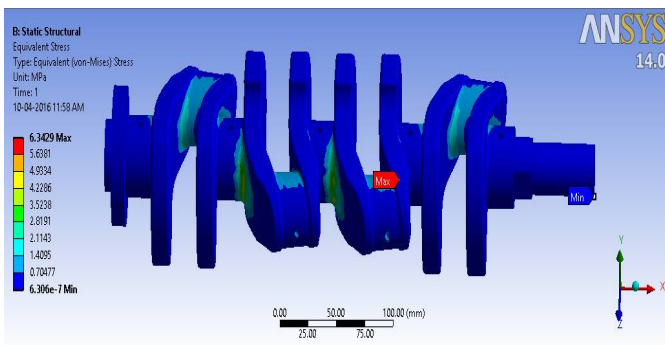

Figure: 19 Equivalent stress-before modification

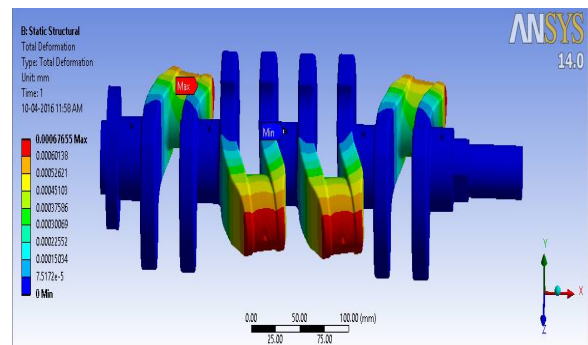

Figure: 20 Total deformation-before modification

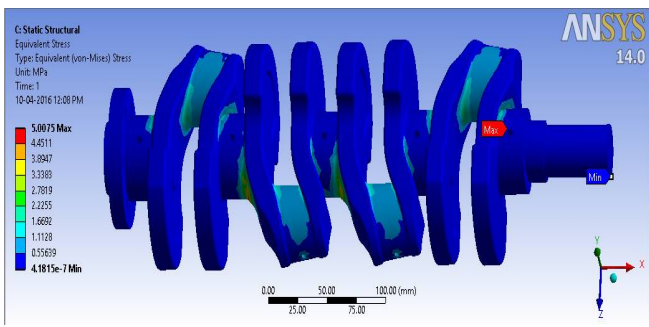

Figure: 21 Equivalent stress-after modifications

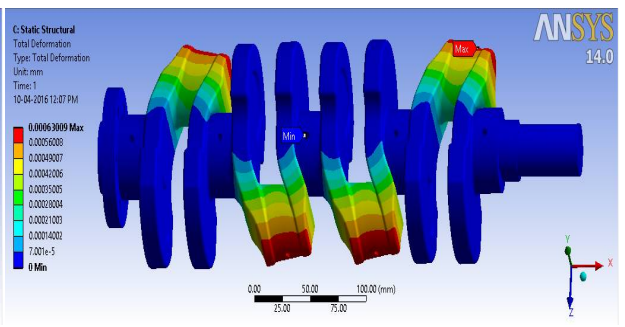
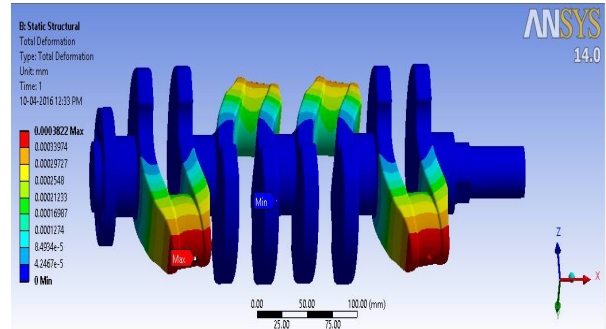
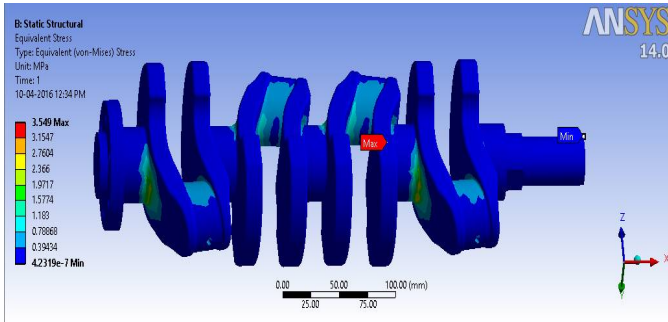

Figure: 22 Total deformation-after modification

The figure 19 and 21 shows equivalent stress of the model before and after modification at 3500N for the material Gray cast iron .And the figure 20 and 22 shows the Total deformation of the model before and after modification of the model crankshaft. The stress and deformation are less at after modification of the model compared from before modification of the model.

**STATIC ANALYSIS FOR COPPER ALLOY AT 2000N AND 3500N:**



**Figure: 23** Equivalent stress-before modification **Figure: 24** Total deformation-before modification

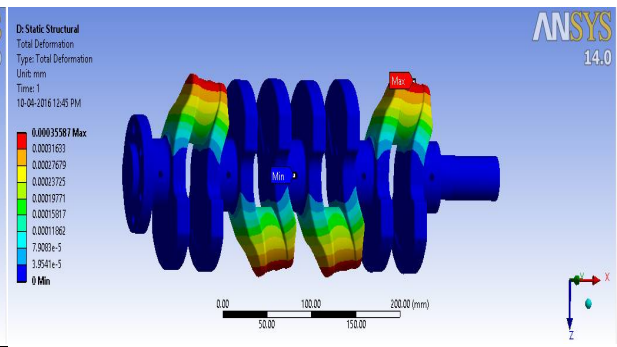
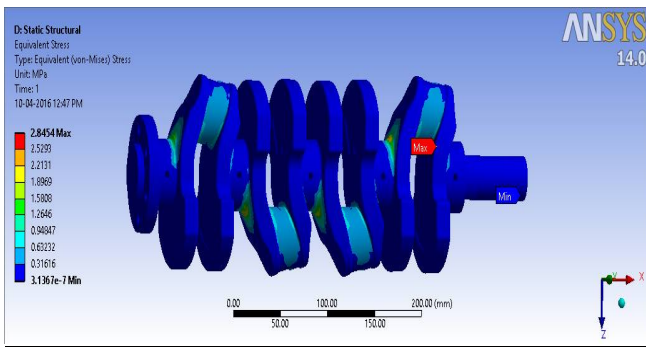

**Figure: 25** Equivalent stress-after modification

**Figure: 26** Total deformation-after modification

The figure 23 and 25 shows equivalent stress of the model before and after modification at 2000N for the material Copper alloy .And the figure 24 and 26 shows the Total deformation of the model before and after modification of the model crankshaft. The stress and deformation are less at after modification of the model compared from before modification of the model.

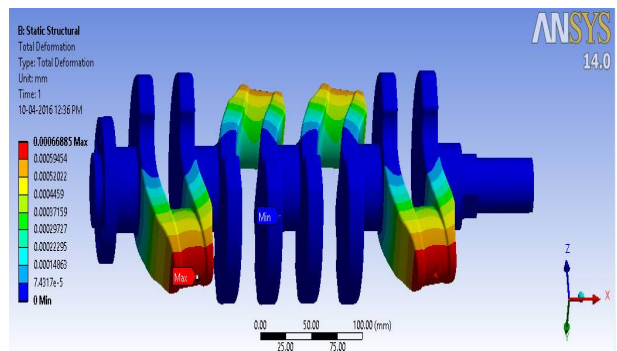
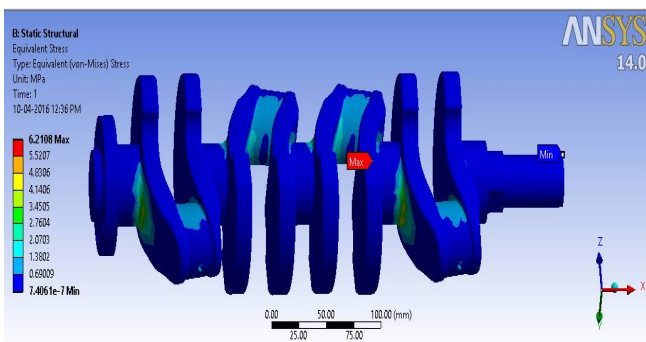

**Figure: 27** Equivalent stress-before modification

**Figure: 28** Total deformation-before modification

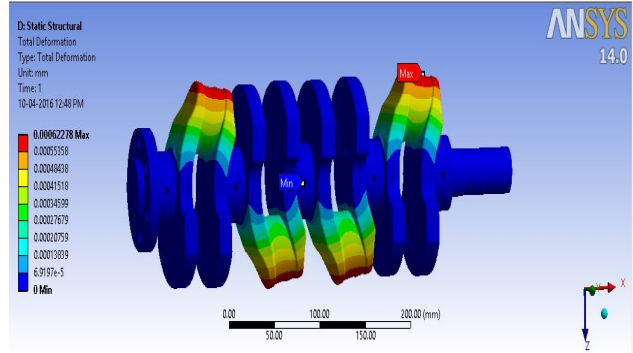
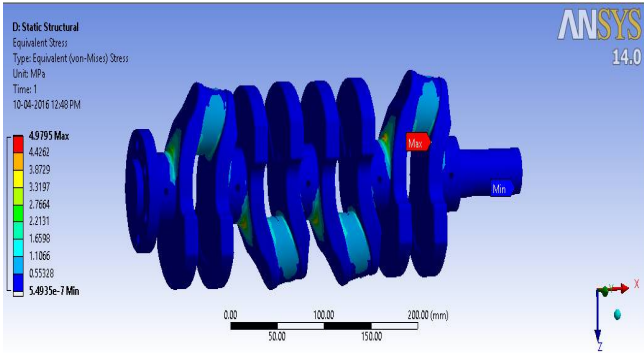

Figure: 29 Equivalent stress-after modification

**30 Total deformation-after modification**

The figure 27 and 29 shows equivalent stress of the model before and after modification at 3500N for the material Copper alloy .And the figure 28 and 30 shows the Total deformation of the model before and after modification of the model crankshaft. The stress and deformation are less at after modification of the model compared from before modification of the model.

**V. RESULTS AND DISCUSSIONS**

**STATIC AND DEFORMATION ANALYSIS RESULTS FOR STEEL, IRON AND COPPER MATERIALS AT 2000N:**

**TABLE: 1 Stress results at 2000N**

material	Stress values (MPa)	
	Before modification	After modification
Structural steel	3.5971	2.8529
Gray cast iron	3.6245	2.8614
Copper alloy	3.549	2.8454

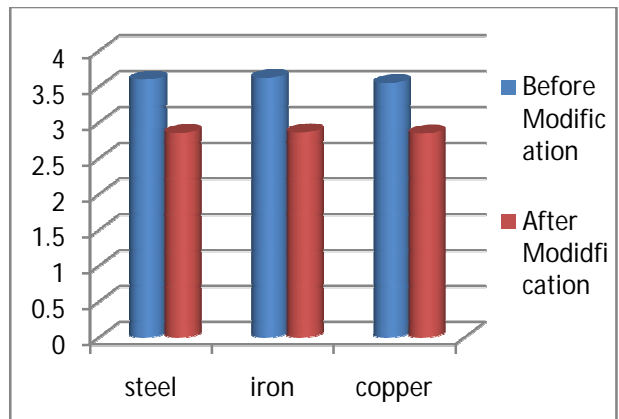

**Figure: 31 Stress comparison for different materials**

The stress value of structural steel before modification is 3.5971MPa and after modification the stress value is 2.8529MPa. For gray cast iron stress value before modification is 3.6245MPa and after modification 2.8614MPa .for copper alloy the stress value before modification is 3.549MPa and after modification stress value becomes 2.8454MPa.



## International Journal of Innovative Research in Science, Engineering and Technology

(An ISO 3297: 2007 Certified Organization)

Vol. 5, Issue 6, June 2016

**TABLE: 2 Deformation results at 2000N**

Material	Deformation values(mm)	
	Before modification	After modification
Structural steel	0.00021197	0.0001974
Gray cast iron	0.0003866	0.00036005
Copper alloy	0.0003822	0.00035587

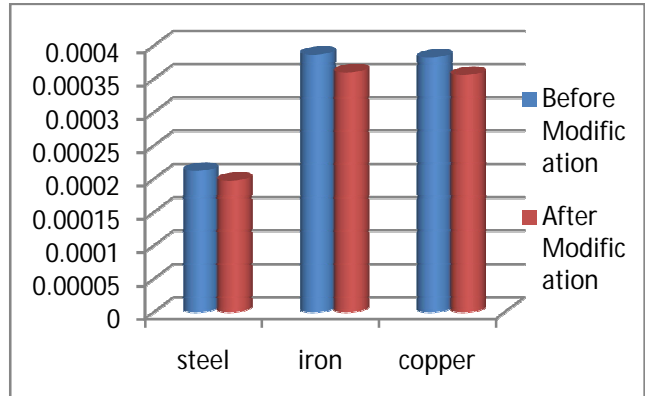

**Figure: 32 deformation comparison for different materials**

The deformation value of structural steel before modification is 0.00021197 mm and after modification the deformation value is 0.0001974 mm. For gray cast iron deformation value before modification is 0.0003866 mm and after modification 0.00036005 mm. For copper alloy the deformation value before modification is 0.0003822 mm and after modification deformation value becomes 0.00035587 mm.

### STATIC AND DEFORMATION ANALYSIS RESULTS FOR STEEL, IRON AND COPPER MATERIALS AT 3500N:

**TABLE: 3 Stress results at 3500N**

Material	Stress values (MPa)	
	Before modification	After modification
Structural steel	6.2949	4.9924
Gray cast iron	6.3429	5.0079
Copper alloy	6.2108	4.9795

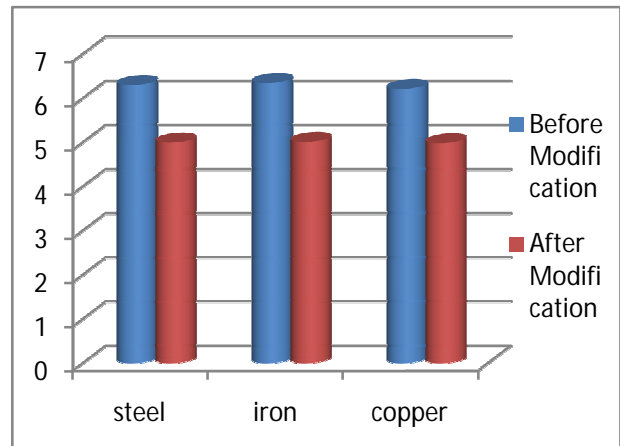

**Figure: 33 stress comparison for different materials**

The stress value of structural steel before modification is 6.2949MPa and after modification the stress value is 4.9924MPa. For gray cast iron stress value before modification is 6.3429MPa and after modification 5.0079MPa .for copper alloy the stress value before modification is 6.2108MPa and after modification stress value becomes 4.9795MPa.

# International Journal of Innovative Research in Science, Engineering and Technology

(An ISO 3297: 2007 Certified Organization)

Vol. 5, Issue 6, June 2016

**TABLE: 4 Deformation results at 3500N**

Material	Deformation values (mm)	
	Before modification	After modification
Structural steel	0.00037095	0.0003454
Gray cast iron	0.00067655	0.00063009
Copper alloy	0.00066885	0.00062278

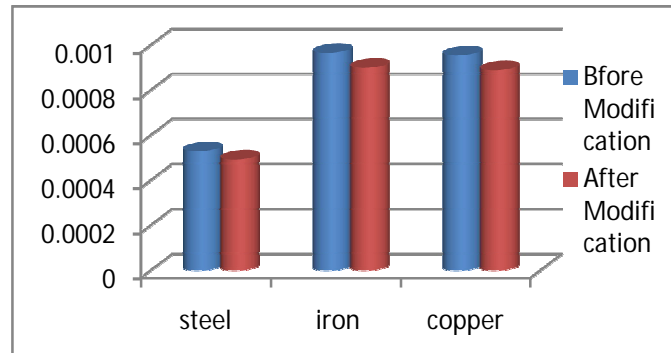

**Figure: 34 Deformation comparison for different materials**

The deformation value of structural steel before modification is 0.00037095 mm and after modification the deformation value is 0.0003454 mm. For gray cast iron deformation value before modification is 0.00067655 mm and after modification 0.00063009 mm. For copper alloy the deformation value before modification is 0.00066885 mm and after modification deformation value becomes 0.00062278 mm. From the graph we have shown that the deformation values of crankshaft after modification are less compared from before modification.

## VI. CONCLUSION

The static analysis is performed for the multi cylinder diesel engine crankshaft for structural steel, Grey cast iron, Copper alloy. In the results the stress and deformation values for all materials are reduced by model modification. At different applied forces the stress and deformation values are low compared from the before model modification. From the above material structural steel shows the low stress and deformation values for all applied force values. By comparing the results we can conclude that the structural steel is best material used for crankshaft which does not cause the breakage of the crankshaft and its better performance. And also conclude that from the above results we suggest that the modification is acceptable.

## REFERENCES

- [1]. A. Solanki, K. Tamboli, M. J. Zinjuwadia, "Crankshaft Design and Optimization-A Review" National Conference on Recent Trends in Engineering & Technology, 2011.
- [2]. Gu Yingkui, Zhou Zhibo, "Strength Analysis of Diesel Engine Crankshaft Based on PRO/E and ANSYS", Third International Conference on Measuring Technology and Mechatronics Automation, 2011.
- [3]. Abhishekchoubey, JaminBrahmbhatt, "Design and Analysis of Crankshaft for single cylinder 4-stroke engine", International Journal of Advanced Engineering Research and studies, vol-1, issue-4, ISSN:2249-8974, pages: 88-90, July-sept 2012.
- [4]. R.J Deshbhratar, Y.R Suple, " Analysis and optimization of Crankshaft using FEM", International Journal of Modern Engineering Research, vol-2, issue-5, ISSN:2249-6645, pages:3086-3088, Sept-Oct 2012.
- [5]. Zoroufi, M. and Fatemi, A., "A Literature Review on Durability Evaluation of Crankshafts Including Comparisons of Competing Manufacturing Processes and Cost Analysis", 26th Forging Industry Technical Conference, Chicago, IL, November 2005.
- [6]. Z. Guangming, J. Zhengfeng, "Study on Torsional Stiffness of Engine Crankshaft" International Forum on Computer Science Technology and Applications, pp 431-435, 2009
- [7]. J. Meng, Y. Liu, R. Liu, "Finite Element analysis of 4-Cylinder Diesel Crankshaft" I.J. Image, Graphics and Signal Processing, vol 5, pp 22-29, 2011
- [8]. Xiaorong Zhou., Ganwei Cai., Zhuan Zhang. Zhongqing Cheng., "Analysis on Dynamic Characteristics of Internal Combustion Engine Crankshaft System", International Conference on Measuring Technology and Mechatronics Automation, 2009
- [9]. C. M. Balamurugan, R. Krishnaraj, M. Sakthivel, K. Kanthavel, D. Marudachalam, R. Palani, "Computer Aided Modelling and Optimization of Crankshaft" International Journal of Scientific & Engineering Research, vol 2, issue 8, 2011.
- [10]. F. H. Montazersadgh, A. Fatemi, "Project Report on Stress Analysis and Optimization of Crankshafts Subject to Dynamic Loading" The University of Toledo, 2007.