

Mechanically Operated Reversible Radiator Fan Blade

Ashwani Sinha¹, Mukesh Jha², Pratul Vishwakarma³

U.G. Student, Department of Automobile Engineering, MCKV Institute of Engineering, West Bengal, India¹

Former Student, Department of Mechanical Engineering, Lovely Professional University, Punjab, India²

Former Student, Department of Mechanical Engineering, Lovely Professional University, Punjab, India³

ABSTRACT: This research is done on radiator fan cooling system in which blades is reversed by using mechanical linkage for cleaning purpose. Debris and dust in extreme conditions like in farms and industries created challenge for radiator on cooling system. The particulate material clog the cooling fins and fan starts to act like a vacuum cleaner. Then air flow must be reversed by reversing the direction of the blade which is the effective method of removing the debris. Now in our consideration blades linkage are so designed that can be operated mechanically. This reduces the chances of overheating of engine, hydraulic oil and transmission however contributes to increase the overall efficiency of the engine which is in today's scenario the most important key factor for any machinery. So, this mechanical system is designed to increase the efficiency of the engine while saving the costliest time and money.

KEYWORDS: Radiator Fan, Reversible, Mechanical linkage, Fan.

I. INTRODUCTION

Aforementioned, in extreme conditions, farms and most agricultural industries are facing the problem of air cooling system due to the clogged particulate materials in the cooling fins of radiator which decreases the efficiency because of the engine getting heated and increases the downtime of the machines. So the reversible radiator fan can be used to well-off this problem. Looking at the same context, through this paper we have explained a reversible radiator fan design concept which can be operated manually using a simple mechanical linkage instead of using any actuation by air compressor. The simplicity of design, durability and compactness of the radiator fan linkage makes it compatible for all varieties of agro machinery, construction machine and recycling machine.

There are many leading manufacturers of agro machinery and construction equipment like Mahindra & Mahindra who export their tractors to 22 countries worldwide Jiangling tractors companies produces lenar tractors for export to US and Europe.[1] TAFE's partnership with AGCO Corporation and the Massey Ferguson brand for 55 years supports its three tractor brands of Massey Ferguson, TAFE and Eicher. TAFE exports tractors in partnership with AGCO and independently in over 85 countries including developed countries in Europe and the Americas. [2]The Escorts-Amuljoint ventureset up a modern production facility at Rajkot with a capacity to produce over 10,000 tractors a year.[3] Still they are not equipped with any such technology which can well-off this situation. With theobjective of solving this encountered problem we have proposed a model of a Reversible Radiator Fan.

II. RELATED WORK

Cleanfix is the company who invented the radiator reversible fan concept in 1998. The fan blade are rotated with pneumatic or hydraulic actuation. The pneumatic actuation either takes place via compressed air system of the vehicle and an intermediate valve, or a cleanfix compressor unit. The hydraulic operation takes place via hydraulic supply of the vehicle and an interposed valve. But this concept is costly due the electronics being used and hence not being implemented by many leading companies.

International Journal of Innovative Research in Science, Engineering and Technology

(An ISO 3297: 2007 Certified Organization)

Vol. 5, Issue 9, September 2016

III. MAIN FUNCTION OF RADIATOR FAN

The fan mounted on the impeller spindle driven by a suitable belt pulley arrangement draws air through the spaces between the radiator tubes thus bringing down the temperature of water appreciably. [4]

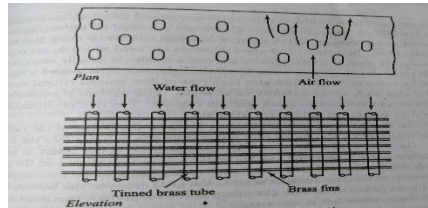

Fig (I) Air flow through fins

IV. DESIGN PROPOSED TO SOLVE ENCOUNTERED PROBLEM

Reversible Radiator Fan

Problem: The problem we are going to discuss is mainly related to the farming or other operation which are done with Tractors, agro machinery and construction machine. For example while ploughing the muddy field with tractor the dust is clogged the spaces between the radiator tubes which hinders the flow of air through it as shown in Fig(II). Because of this the engine of the tractor gets heated that reduce the efficiency of the machineries.



Fig (II) Clogged Radiator

Design Approach

The reversible radiator fan is a mechanically actuated fan which is able to reverse the flow of the air. When the excess clogging of the mud or dust occurs on the surface of the radiator we can throw it out by reversing the direction of the propellers of the fan. It is with the mechanical linkage which allows the operator to reverse the direction of the propellers by pulling a single lever.

Parts of the Fan:

The table below represent the different part of fan assembly and the Fig(a) and Fig(b) represents the parts of the fan as numbered in the table. Fig(c) represents isometric view of the fan. Fig(d) represents the side view of the fan. Fig(e) represents the front view of the fan. Fig (f) represents all the linkage assembly of the fan.

Table:

1.Propeller	2.Propeller Linkage	3.Connecting Link	4.Shifting Link	5.Hollow Rod Shifter	6.Hub	7.Shaft	8.Collar Bearing
9.Fork Shifter	10.Piston	11.Cylinder	12.Plunger	13.Lever	14.Front Cover	15.Back Cover	16.Base tractor Body

International Journal of Innovative Research in Science, Engineering and Technology

(An ISO 3297: 2007 Certified Organization)

Vol. 5, Issue 9, September 2016

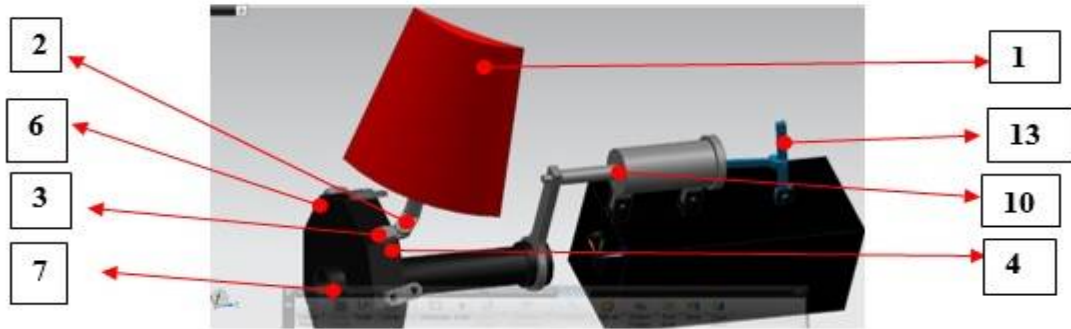

Fig(a)



Fig (b)

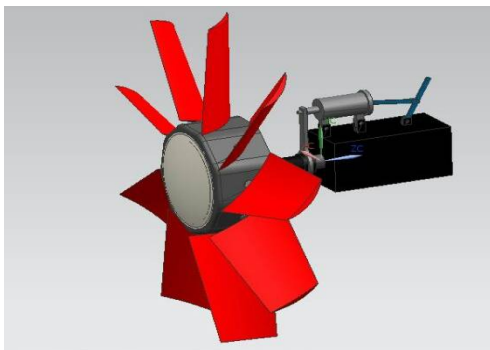

Fig (c)

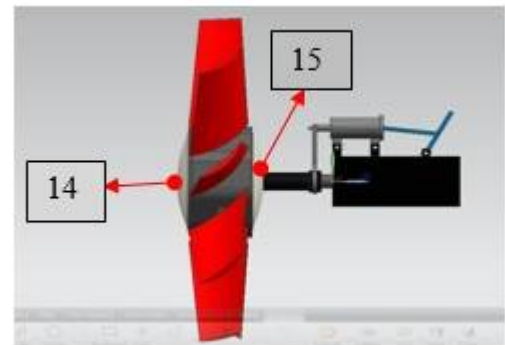

Fig (d)



Fig (e)



Fig (f)

International Journal of Innovative Research in Science, Engineering and Technology

(An ISO 3297: 2007 Certified Organization)

Vol. 5, Issue 9, September 2016

V.MATERIAL SELECTION FOR THE VARIOUS PARTS OF THE RADIATOR FAN

- 1. Propeller:** As the propeller is the main part of the fan, it controls the flow of the air through it. For the material selection of the blades it is needed to go for the analysis of the air flow that is air flow simulation through the fan. The blades are rotated between a certain range of the rpm as per the engine is throttled, which causes two fundamental effects on the blades, one is heat effect on it due to flow of the air and another one is cantilever force on it due to drag force on it. As per the analysis we have come to the conclusion for using FRP (Fibre Reinforced Plastic) as best suited for the blades to be manufactured after comparing with other materials like Cast Aluminium, Aluminium Alloy and other lightweight materials which are able to exhaust the heat and sustain the applied load.
- 2. Propeller Linkage:** Propeller linkage are the parts of the fan which are used to transmit the force applied by the operator to reverse the direction of the propellers that is why they undergo the tensile force. For selection of the material of the connecting linkage it is taken into consideration that the material should be well able to bear the tensile load as per the dimensional design of the link and one another requirement of the material is that it should be light weight that's why after the analysis the outcome shows to use the Alloy Aluminium to manufacture the linkages.
- 3. Connecting Linkage, Shifting Link and Hollow Rod shifter:** As the Propeller linkage, Connecting linkages, Shifting Link and Hollow Rod Shifter are all assembled together to transmit the force so that all these parts are decided to be manufactured of the same material that is preselected Aluminium Alloy.
- 4. Hub, Front Cover, Back Cover, Cylinder, Piston and Shaft:** Hub is the main body of the whole fan as all the parts are mounted on it and shaft transmits the rotational motion directly to it that is why we can manufacture it with Cast Aluminium which will give the advantage of good damping, strength and light weight material.
- 5. Collar Bearing:** As it is a part which is to be used directly from the market by the selection basis. For selecting the bearing it is needed to select the load bearing capacity of the whole system and according to it we can directly select the bearing as per the availability in the market.
- 6. Fork shifter, Plunger and Lever:** These are the linkages which transmit the force under the tension as well compression so for this it is needed to select a material having such a quality that can sustain under both type of loads. After analysing some materials, medium carbon steel appears as a better material than any other.

VI.ASSEMBLY AND WORKING

Propellers of the fan is so designed that it can be operated in both the directions as a mirror image. That means the propeller's fins are designed symmetrical about its central axis to obtain the same type of air flow for both the directions. *Propeller Linkage* is the link which connects the propeller to the *Connecting Link* which is further mounted on the *Shifting Ring*. Propeller Linkage also hinges the propeller on the *Hub* and keeps it rigidly fix on it. *Connecting Link* works as a Crank of a four bar linkage in this whole mechanism. It has the main role in the mechanism as it is responsible for giving the rotation to the propellers by means of *Shifting Ring*. Shifting Ring is a ring on which all the nine Connecting Links are mounted as the Fan is having total nine propellers. The Ring is connected with *Hollow Rod Shifter* which is nothing but a hollow shaft which slides on the *Shaft* of the Fan. The Shifter allows a translating motion to the Shifting Ring while the whole fan is rotating at a higher RPM. On the Hollow rod shifter a *Collar Bearing* is mounted to give relative motion between Hollow Rod Shifter and *Fork Shifter* because the Rod Shifter has to rotate as well as to make the translatory motion to shift the ring in motion. Further the Fork Shifter is connected with *Piston and Cylinder* assembly to gain the translatory motion by means of *Plunger* connected with the *Lever* operated by the operator to give the motion to overall assembly. Finally the *Base* can be the body of the Tractor on which the whole assembly is to be mounted. *Front and Back Covers* are mounted on the Hub to seal the inner assembly from the dust.

Piston Cylinder assembly is an actuating device for the ease of the operators to operate the lever. There may more alternatives of the method of actuation for giving the actuation from the operator hand to the *Fork Shifter*.

For Example: Piston Cylinder can be replaced by Hydraulic circuit which requires less effort of the operator. And using the Four Bar linkage actuation makes it less costly.

International Journal of Innovative Research in Science, Engineering and Technology

(An ISO 3297: 2007 Certified Organization)

Vol. 5, Issue 9, September 2016

VII.CONCLUSION

In countries like China and India where agriculture is the main contributor of their economy but their agro machineries lacks in such technologies which ultimately converges the rate of production. Then this concept finds a suitable space in indemnifying the loss of production.

REFERENCES

- [1] Ashwani Sinha, Mukesh Jha, Pratul Vishwakarma, "Mechanically Operated Reversible Radiator Fan", Vol.5, Issue 9, September, 2016.
- [2] https://en.wikipedia.org/wiki/Jiangling_Tractors
- [3] https://en.wikipedia.org/wiki/Tractors_and_Farm_Equipment_Limited
- [4] <http://www.thehindubusinessline.com/companies/escorts-forms-jv-with-amul-group-for-specialized-tractors/article7098945.ece>
- [5] McGrawHillEducation "V Ganeshan Internal Combustion Engines".