

## International Journal of Innovative Research in Science, Engineering and Technology

(An ISO 3297: 2007 Certified Organization)

Website: [www.ijirset.com](http://www.ijirset.com)

Vol. 6, Issue 4, April 2017

# Secure Transmission of Image and Data Using RDH Technique

Abhilasha Sawant<sup>1</sup>, Shilpa Shetty<sup>1</sup>, Shivani Singh<sup>1</sup>, Amit Waware<sup>1</sup>, Prof. Archana Gaikwad<sup>2</sup>

B. E Students, Dept. of Computer Engineering, Dr. D Y Patil School of Engineering, Lohegaon, (CharoliBk), Savitribai  
Phule Pune University, Pune India.<sup>1</sup>

Professor, Dept. of Computer Engineering, Dr. D Y Patil School of Engineering, Lohegaon, (CharoliBk), Savitribai  
Phule Pune University, Pune India.<sup>2</sup>

**ABSTRACT:** These Steganography is the art of hiding the existence of data in another transmission medium to achieve secret communication and Reversible Data Hiding (RDH) in images is a technique by which the image can be retrieved back after extracting the secret messages embedded in it. The present methods involve reserving room for the secret message before encrypting the message into the cover image. so that the cover image can be effectively retrieved after extracting the secret message by the receiver. But the method involves some disadvantages which reduces the efficiency of this method. The primary disadvantage that the key generation used in Reversible data hiding method is by using random value. When the random value is used in key generation, it can be effectively regenerated by the invaders. So this proves to be inefficient in security. In this paper we propose a new method in which we make use Rivest-Shamir-Adleman algorithm for the key generation which effectively increase the security as the key generation is difficult. This method can also be used to encrypt the message in the video also. The security is highly improve in the new method which is proved by using various experiments. Today reversible information stowing away in encoded pictures by saving room before encryption is an imperative method is use in different use of security. Where information security is essential imperative. This instrument is essential use in inelegancy office. At some point when we manage an information and that information is watched outsider client and that circumstance you need to shroud information specifically system that time we can utilize this reversible information stowing away in encoded pictures by holding room before encryption procedure. In this paper, we propose a novel strategy by holding room before encryption with a conventional RDH calculation, and in this manner it is simple for the information hider to reversibly insert information in the scrambled picture. The proposed technique can accomplish genuine reversibility, that is, information extraction and picture recuperation are free of any blunder. Tests demonstrate that this novel technique can implant more than 10 times as vast payloads for a similar picture quality as the past strategies, for example, for PSNR dB.

**KEYWORDS:** Reversible data hiding, image encryption, privacy protection, histogram shift, Reversible Data Hiding, RDH, PSNR, VRAE

### I. INTRODUCTION

Using encryption keys is a traditional method of image encryption can be carried out using DES, AES algorithms, digital signatures, vector quantization, chaos theory etc. In some cases secret key used for encryption is restricted and may have some limitations. It is inapt due bulk size of data. Also it requires heavy computational cost. In contrast to this technique image encryption without using key provides more security as there is no need to maintain secret key, involves low encryption/decryption cost. Encryption technique without using secret key includes generation of random shares; this technique is known as visual cryptography. Visual cryptography is a process where the secret image is encrypted into shares which refuse to provide information about the original secret image. The strength of this method is that the decryption of the secret image is through human visual system without computation. Thus the proposed approach gives a secure novel technique for reversible data hiding using visual cryptography.

# International Journal of Innovative Research in Science, Engineering and Technology

(An ISO 3297: 2007 Certified Organization)

Website: [www.ijirset.com](http://www.ijirset.com)

Vol. 6, Issue 4, April 2017

With the scheme using secret keys have limitations regarding key management. In some cases the available secret keys for encryption are limited and have some restricted space, also high computation involved in encryption. All these factors highlight the problem domain for using traditional encryption techniques in reversible data hiding. In converse to this approach is visual cryptography that involves no use of keys for encryption. Thus the computations required are also less. The proposed scheme suggests the novel approach for data hiding and image encryption. Since lossless vacating the room from the encrypted image is difficult and sometimes inefficient thus proposed scheme apply a method of vacating the room for data prior to the image encryption [1], thus vacated room can be used to hide the secret data. By reversing the order of encryption and data hiding we overcome the difficulty of finding the space for data from already encrypted image. The objective behind this is to implement secure keyless image encryption technique and to improve the quality of marked decrypted image. Bit plane slicing of digital image is used to provide more security. The main objective of BPS is used to divide the digital image into 8 bit planes such that the bit-plane is further rotated in order to provide better encrypted image and to make hacking more difficult. It focuses on two techniques such as bit plane slicing and image rotation for efficient image encryption. This is system which can use to recuperate unique picture with no information misfortune. we can put cover on unique picture and concentrate this cover subterranean insect get a unique information. Presently we can present about the framework. This is a system in which we can recoup unique picture after the installed message is separated. This is use in restorative symbolism, military symbolism and law legal sciences, where no mutilation of the first cover is permitted. Since rest presented, RDH has pulled in significant research intrigue.

Accordingly, system of reversible information shading is on encoded information is favored. Assume a medicinal picture database is put away In a server farm, and a server in the server farm can install documentations into a scrambled rendition of a therapeutic picture through a RDH procedure. With the documentations, the server can deal with the picture or confirm its honesty without having the learning of the first substance, and subsequently the patient's security is ensured. In this Existing System, since lossless clearing room from the encoded pictures is generally troublesome and now and then wasteful, why are we still so fixated to discover novel RDH procedures working specifically for Encrypted Images? The technique in compacted the encoded LSBs to empty space for extra information by discovering disorders of an equality check lattice, and the side data utilized at the collector side is likewise the spatial relationship of decoded pictures. All the three strategies attempt to abandon room from the scrambled pictures specifically. Be that as it may, since the entropy of encoded pictures has been amplified, these methods can just accomplish little payloads produce stamped picture with low quality for expansive payload and every one of them are liable to some mistake rates on information extraction and additionally picture restoration. Reversible information concealing (RDH) in pictures is a strategy, by which the first cover can be lossless recuperated after the installed message is extricated. This imperative strategy is generally utilized as a part of restorative symbolism, military symbolism and law crime scene investigation, where no mutilation of the first cover is permitted. Since initially presented, RDH has pulled in impressive research intrigue. In hypothetical angle, Kalker and Willems built up a rate-contortion display for RDH, through which they demonstrated the rate-bending limits of RDH for memory less covers and proposed a recursive code development which, be that as it may, does not approach the bound. Zhang et al. enhanced the recursive code development for double covers and demonstrated that this development can accomplish the rate-mutilation bound the length of the pressure calculation achieves entropy, which builds up the equality between information pressure and RDH for twofold covers.

## II. LITERATURE REVIEW

Lots of research has been done in the area of reversible data hiding. In last few years different methods have been proposed for reversible data hiding and color image visual cryptography. Some noticeable work in area of reversible data hiding is as follows:

Kede Ma, Weiming Zhang, Xianfeng Zhao, Nenghai Yu and Fenghua Li1 has proposed a framework for reversible data hiding for embedding data in an image by reserving room before encryption, as vacating room from the encrypted images is difficult and inefficient. Embedding data prior to image encryption also results in lossless retrieval of image.

## International Journal of Innovative Research in Science, Engineering and Technology

(An ISO 3297: 2007 Certified Organization)

Website: [www.ijirset.com](http://www.ijirset.com)

Vol. 6, Issue 4, April 2017

Jun Tian has introduced a difference expansion technique which finds extra storage space by exploring the redundancy in the image content. Secret data holding capacity limit and the visual quality of embedded images of the DE method are among the best methods, along with a low computational complexity. From information hiding point of view, reversible data embedding technique hides some information in a digital image in such a way that third party could decode the hidden information and also restore the original image. The performance of RDH algorithm can be evaluated by following parameters:

- 1) Payload capacity limit: what maximum amount of information can be embedded?
- 2) Visual quality: the visual quality of the embedded image?
- 3) Complexity: what is the complexity of algorithm.

R. Vijayaraghavan, S. Sathya and N. R. Raajan proposed a bit slice rotation method of digital image for more security. Bit Plane Slicing is used to divide the digital image into 8-bit planes. The bit plane is further rotated such that to provide better encrypted image and to make hacking more difficult. The classification of bit plane is used for analyzing the importance played by each bit of an image. It is used to estimate each pixel of an image. The proposed scheme involves rotation of bit planes providing highly secure image encryption. By this method scrambling of an image is based on efficient technique even it is intercepted, the information cannot be understood. It is mainly useful for image compression because it exhibits high coding efficiency.

Zhicheng Ni, Yun-Qing Shi, Nirwan Ansari, and Wei Su, gave a novel reversible data hiding algorithm, which can recover the original image without any distortion from the marked image after the hidden data have been extracted. This algorithm utilizes the zero or the minimum points of the histogram of an image and slightly modifies the pixel gray scale values to embed data into the image. This can hide more data than many of the existing RDH algorithms. It is proved analytically and shown experimentally that the peak signal-to-noise ratio (PSNR) of the marked image generated by this method versus the original image is guaranteed to be more than 48 dB. This lower bound of PSNR is much higher than that of all reversible data hiding techniques reported in the literature. The computational complexity of the proposed technique is low and the execution time is less.

Asha S.N, Dr. Shreedhara, Visual cryptography is a method where the secret image is divided into two or more shares which are known as shares and the secret image is revealed by overlaying the shares without any complex computation involved. This paper defines how to implement the embedded extended visual cryptography scheme by taking more than one input as well as secret image. The image visual quality metrics like PSNR, MSE and MAXERROR are defined here. The generations of covering shares are carried out with the help of half-toning technique using dithering matrix.

The mystery information ought to remain covered up in a host flag, regardless of the possibility that that flag is subjected to controls as separating, resampling, editing, or lossy information pressure. Since nobody's strategy is fit for accomplishing every one of these objectives, a class of procedures is expected to traverse the scope of conceivable applications. Trade-offs exist between the amount of information and the resistance to change. In different applications, for example, remote detecting and high-vitality molecule physical trial examination, it is likewise sought that the first cover media can be recuperated on account of the required high-accuracy nature. The checking procedures fulfilling this prerequisite are alluded to as reversible, lossless, bending free, or invertible information concealing systems. [1]

Reversible information stowing away encourages enormous probability of uses to connection two arrangements of information in a manner that the cover media can be losslessly recuperated after the shrouded information has been removed out, in this way giving an extra road of taking care of two distinct arrangements of data [2]. This strategy for reversible information concealing system can implant around 5–80 kb into a 512x512x8 dark scale picture while ensuring the PSNR of the stamped picture versus the first picture to be over 48 dB. Many RDH techniques have been proposed since it was presented, Xinpeng Zhang proposed distinct reversible information covering up in encoded pictures. In the main stage, a substance proprietor scrambles the first uncompressed picture utilizing an encryption key. [2]

At that point, an information hider may pack the slightest huge bits of the scrambled picture utilizing an information concealing key to make a meager space to oblige some extra information (i.e., Vacating Room After Encryption

# International Journal of Innovative Research in Science, Engineering and Technology

(An ISO 3297: 2007 Certified Organization)

Website: [www.ijirset.com](http://www.ijirset.com)

Vol. 6, Issue 4, April 2017

(VRAE) strategy). With a scrambled picture containing extra information, if a collector has the information concealing key, he can separate the extra information however he doesn't know the picture content. On the off chance that the collector has the encryption key, he can decode the got information to acquire a picture like the first one, however can't separate the extra information. The technique in fragments the encoded picture into various non-covering obstructs; every square is utilized to convey one extra piece. The technique decreased the blunder rate of the strategy by completely abusing the pixels in ascertaining the smoothness of every piece and utilizing side match. The strategy in compacted the scrambled LSBs to clear space for extra information by discovering disorders of an equality check framework and to isolate the information extraction from picture unscrambling, discharged out space for information implanting taking after packing encoded images.[3]

Here, a novel technique is proposed in order to scramble pictures utilizing RDH , for which "abandon room after encryption" is not done, but rather "hold room before encryption "where, first discharge out room by inserting LSBs of a few pixels into different pixels with a customary RDH strategy and afterward encode the picture, so the places of these LSBs in the encoded picture can be utilized to implant information which accomplishes fabulous execution in two unique prospects

1. Real reversibility is acknowledged, i.e., information extraction and picture recuperation are free of any mistake.
2. For given installing rates, the PSNRs of decoded picture containing the inserted information are essentially enhanced and for the worthy PSNR, the scope of implanting rates is enormously extended. [4]

Reversible information concealing (RDH) in pictures is a system, by which the first cover can be lossless recouped after the implanted message is extricated. This essential strategy is Generally utilized as a part of restorative symbolism, military symbolism and law legal sciences, where no twisting of the first cover is permitted. Since initially presented, RDH has pulled in significant research intrigue. In hypothetical perspective, Kalker and Willems built up a rate-mutilation display for RDH, Through which they demonstrated the rate-contortion limits of RDH for memory less covers and proposed a recursive code development which, be that as it may, does not approach the bound. Zhang et al. enhanced the recursive code development for parallel covers and demonstrated that this development can accomplish the rate-mutilation bound the length of the pressure calculation achieves entropy, which sets up the equality between information pressure and RDH for paired covers.[5]

### III. PROPOSED SYSTEM FLOW

As of late, more consideration is paid to reversible information concealing (RDH) in scrambled pictures, since it keeps up the magnificent property that the first cover can be lossless recuperated after inserted information is separated while ensuring the picture substance's secrecy. Every single past technique implant information by reversibly clearing room from the scrambled pictures, which might be liable to a few mistakes on information extraction as well as picture reclamation. In this paper, we propose a novel technique by holding room before encryption with a conventional RDH calculation, and in this manner it is simple for the information hider to reversibly install information in the scrambled picture. The proposed technique can accomplish genuine reversibility, that is, information extraction and picture recuperation are free of any blunder. Proposed system is extremely straightforward strategy for reversible information covering up and removing unique information. In proposed technique can accomplish genuine reversibility, that is, information extraction and picture recuperation are free of any blunder. In the event that we turn around the request of encryption and abandoning room, i.e., saving room preceding picture encryption at substance proprietor side, the RDH assignments in scrambled pictures would be more normal and much simpler which drives us to the novel structure, "holding room before encryption (RRBE)".

# International Journal of Innovative Research in Science, Engineering and Technology

(An ISO 3297: 2007 Certified Organization)

Website: [www.ijirset.com](http://www.ijirset.com)

Vol. 6, Issue 4, April 2017

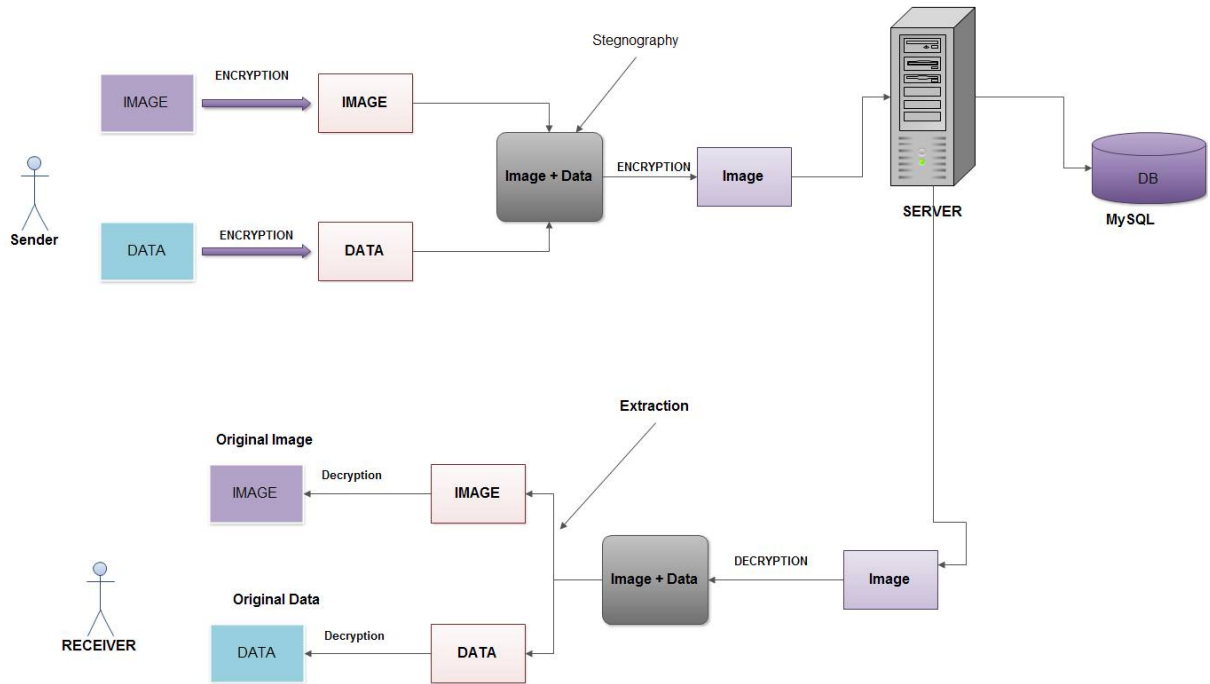
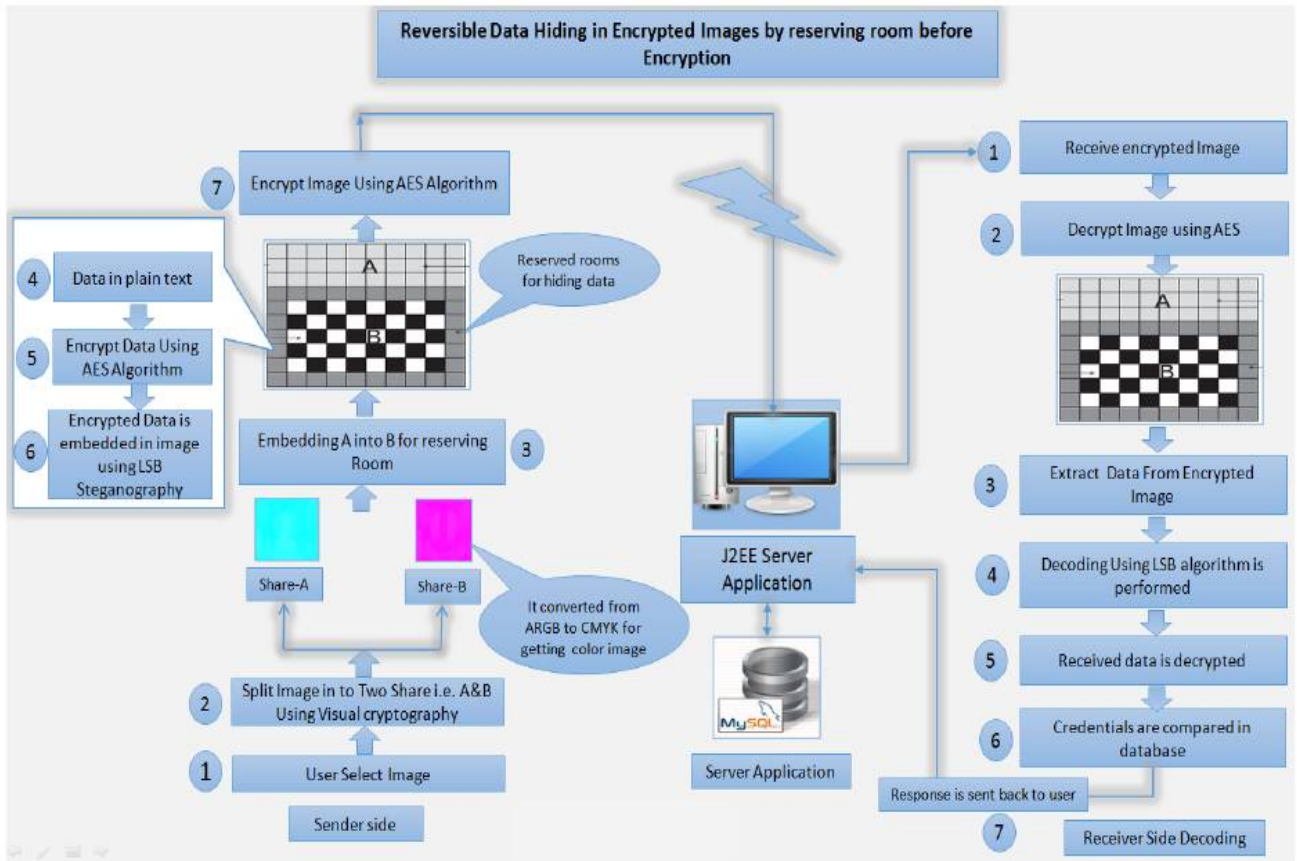

**Fig 1: System Flow**

Since losslessly emptying room from the scrambled pictures is generally troublesome and some of the time wasteful and switching the request of encryption and abandoning room, i.e., holding room preceding picture encryption at substance proprietor side, the RDH assignments in encoded pictures would be more regular and much less demanding which prompts to the novel structure, "Saving Room Before Encryption (RRBE)". As appeared in Figure. 1(b), the substance proprietor first save enough space on unique picture and afterward changes over the picture into its scrambled rendition with the encryption key. Presently, the information inserting process in scrambled pictures is intrinsically reversible for the information hider which needs to suit information into the extra space past discharged out. The information extraction and picture recuperation are indistinguishable to that of Framework VRAE. Clearly, standard RDH calculations are the perfect administrator for saving room before encryption and can be effectively connected to Framework RRBE to accomplish better execution contrasted and methods from Framework VRAE. This is on the grounds that in this new system, the standard thought is taken after i.e., first losslessly packs the excess picture content (e.g., utilizing phenomenal RDH methods) and after that encodes it as for securing protection. Next, expound a commonsense strategy in light of the Framework "RRBE", which essentially comprises of four phases: era of encoded picture, information stowing away in scrambled picture, information extraction and picture recuperation, information extraction and picture reclamation.



**IV. PROPOSED SYSTEM ARCHITECTURE**



**Fig 2: system architecture**

In reversible information concealing strategy we can discover that information can be recoup lossless on the off chance that you can utilize a right procedure. Information is an essential and indispensable part of any field and the mystery of that is likewise vital in a restorative and government and military operation. So this approach gives an essential way to deal with cover up and get information with effortlessly anyplace without misfortune. The proposed strategy can exploit all conventional RDH methods for plain pictures and accomplish fantastic execution without loss of flawless mystery.

**Advantage**

Not only does the proposed method separate data extraction from image decryption but also achieves excellent performance in two different prospects:

1. Real reversibility is realized, that is, data extraction and image recovery are free of any error.
2. For given embedding rates, the PSNRs of decrypted image containing the embedded data are significantly improved; and for the acceptable PSNR, the range of embedding rates is greatly enlarged.

# International Journal of Innovative Research in Science, Engineering and Technology

(An ISO 3297: 2007 Certified Organization)

Website: [www.ijirset.com](http://www.ijirset.com)

Vol. 6, Issue 4, April 2017

## V. ALGORITHM USED

In proposed system we used RC4 algorithm. RC4 was designed in 1987 by Ron Rivest and is one of the most widely software stream cipher and used in popular protocols, such as SSL (protect Internet traffic), WEP (secure wireless networks) and PDF. It's considered to be fast and simple in terms of software. RC4 generates a pseudo-random stream of bits (a key-stream). As with any stream cipher, these can be used for encryption by combining it with the plaintext using bit-wise exclusive-or. Decryption is performed the same way (since exclusive-or is a symmetric operation).

To generate the key stream, the cipher makes use of a secret internal state which consists of two parts:

1. A permutation of all 256 possible bytes (denoted "S" below).
3. Two 8-bit index-pointers (denoted "i" and "j").
4. The permutation is initialized with a variable length key, typically between 40 and 256 bits, using the key-scheduling algorithm (KSA). Then the stream of bits is generated by a pseudo-random generation algorithm.

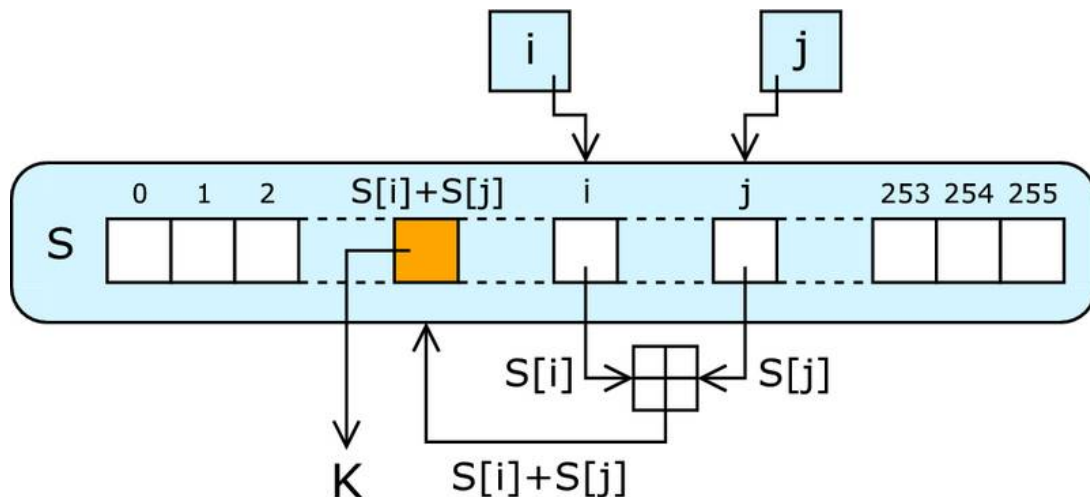

Fig 3: RC4 Algorithm Flow

## VI. EXPERIMENTAL SET UP

All the existing methods gives a method for hiding a data into an image in a reversible manner that in the extraction phase the image will be restored lossless but while the image is holding a data the security of an image is also a major concern especially during transmission. And when the image and the data inside it have a relation in that case both the data and image should not be revealed to the unauthorized user. Thus image can be protected by applying different encryption techniques. In the proposed scheme after application of RDH for hiding data, the image is encrypted using visual cryptography which involves dividing the image into random shares. After data embedding we are modifying pixel values of used pixels. And in order to provide more security during image transmission we are using bit slicing and rotation before shuffling pixels.

# International Journal of Innovative Research in Science, Engineering and Technology

(An ISO 3297: 2007 Certified Organization)

Website: [www.ijirset.com](http://www.ijirset.com)

Vol. 6, Issue 4, April 2017

Image	Size	Operation	Proposed Method		Existing Method	
			Time(ms)	PSNR(db)	Time(ms)	PSNR(db)
Lena	463kb	Data Hiding	3.14	10.32	4.36	7.69
		Data Share	0.12		0.18	
		Reconstruction	0.14	10.96	0.19	7.79
		RDH	3.32		4.610	
Barbara	174kb	Data Hiding	3.21	12.92	3.623	7.39
		Data Share	2.02		2.32	
		Reconstruction	2.57	11.69	3.20	6.74
		RDH	3.07		4.53	
Baboon	611kb	Data Hiding	3.47	18.92	5.03	7.78
		Data Share	0.49		1.02	
		Reconstruction	0.36	19.19	0.90	7.76
		RDH	4.24		5.36	

The proposed scheme offers a high embedding capacity, security and good PSNR ratio as compared to other techniques; higher the PSNR gives better quality of encrypted image. The proposed technique is experimented with the existing standard images; it is also applicable with any type of image. Here size of text used is less than or equal to the size of image. The performance of proposed method is faster than that of existing techniques.

**Table 1 Comparison Table**

Algorithm	PSNR(dB)
Base Paper	30.38
Proposed	32.68

## 1. Decryption time

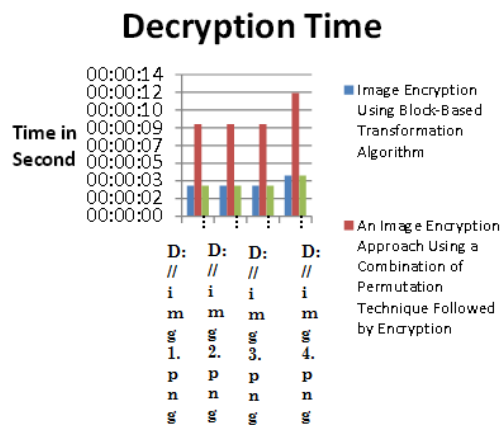

Fig:- Decryption Time for Steganography



# International Journal of Innovative Research in Science, Engineering and Technology

(An ISO 3297: 2007 Certified Organization)

Website: [www.ijirset.com](http://www.ijirset.com)

Vol. 6, Issue 4, April 2017

## 2. Encryption time

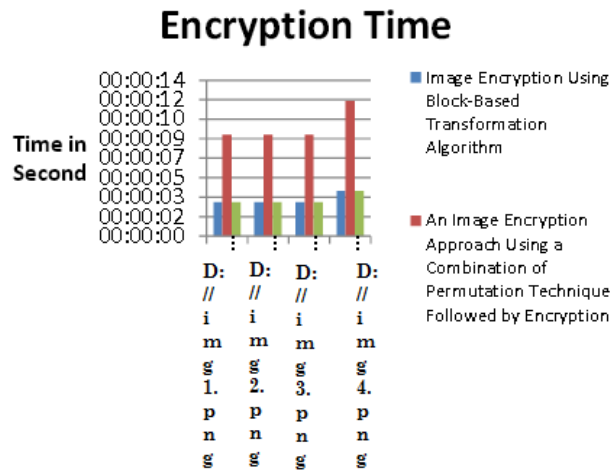

Fig:EncryptionTime for reverse texture

## 3. Original Image graph

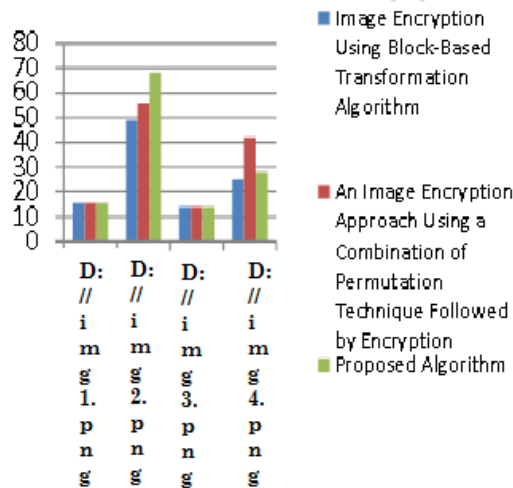

Fig: Original Image in KB

## VII. CONCLUSION

In reversible information concealing strategy we can discover that information can be recuperate lossless on the off chance that you can utilize a right system. Information is a critical and vital part of any field and the mystery of that is additionally vital in a restorative and government and military operation. So this approach gives an essential way to deal with cover up and get information with effortlessly anyplace without misfortune. The proposed strategy can exploit all customary RDH methods for plain pictures and accomplish incredible performance without loss of immaculate mystery. Reversible information covering up in scrambled pictures is another subject drawing

# International Journal of Innovative Research in Science, Engineering and Technology

(An ISO 3297: 2007 Certified Organization)

Website: [www.ijirset.com](http://www.ijirset.com)

Vol. 6, Issue 4, April 2017

consideration on account of the protection safeguarding necessities from cloud information administration. Past strategies execute RDH in scrambled pictures by emptying room after encryption, instead of which holding room before encryption is proposed. Consequently the information hider can profit by the additional space purged out in past stage to make information concealing procedure easy. The proposed strategy can exploit all conventional RDH methods for plain pictures and accomplish brilliant execution without loss of flawless mystery. Besides, this novel strategy can accomplish genuine reversibility, isolate information extraction and incredibly change on the nature of stamped decoded pictures.

## REFERENCES

- [1] J. Fridrich and M. Goljan, "Lossless data embedding for all image formats," in Proc. SPIE Proc. Photonics West, Electronic Imaging, Security and Watermarking of Multimedia Contents, San Jose, CA, USA, Jan. 2002, vol. 4675, pp. 572–583.
- [2] J. Tian, "Reversible data embedding using a difference expansion," IEEE Trans. Circuits Syst. Video Technol., vol. 13, no. 8, pp. 890–896, Aug. 2003.
- [3] Z. Ni, Y. Shi, N. Ansari, and S. Wei, "Reversible data hiding," IEEE Trans. Circuits Syst. Video Technol., vol. 19, no. 7, pp. 989–999, Jul. 2009.
- [4] Sachnev, H. J. Kim, J. Nam, S. Suresh, and Y.-Q. Shi, "Reversible watermarking algorithm using sorting and prediction," IEEE Trans. Circuits Syst. Video Technol., vol. 19, no. 7, pp. 989–999, Jul. 2009.
- [5] M. Johnson, P. Ishwar, V. M. Prabhakaran, D. Schonberg, and K. Ramchandran, "On com-pressing encrypted data," IEEE Trans. Signal Process., vol. 52, no. 10 Oct 2004., pp. 2992–3006.
- [6] M. Armbrust, A. Fox, R. Griffith, A. D. Joseph, R. H. Katz, A. Konwinski, G. Lee, D. A. Patterson, A. Rabkin, I. Stoica, and M. Zaharia, "Above the clouds: A Berkeley view of cloud computing," University of California, Berkeley, Tech. Rep. USB-EECS-2009-28, Feb 2009.
- [7] X. Zhang, "Reversible data hiding in encrypted images," IEEE Signal Process. Lett., vol. 18, no. 4, pp. 255–258, Apr. 2011.
- [8] W. Hong, T. Chen, and H. Wu, "An improved reversible data hiding in encrypted images using side match," IEEE Signal Process. Lett., vol. 19, no. 4, pp. 199–202, Apr. 2012..
- [9] T. Kalker and F. M. Willems, "Capacity bounds and code constructions for reversible data-hiding," in Proc. 14th Int. Conf. Digital Signal Processing (DSP2002), 2002, pp. 71–76.
- [10] Kede Ma, Weiming Zhang, Xianfeng Zhao, Nenghai Yu, and Fenghua Li. Reversible Data Hiding in Encrypted Images by Reserving Room. Before Encryption. IEEE Transaction on Information Forensics and Security: March 2013; Vol. 8; No. 3.
- [11] Jun Tian. Reversible Data Embedding Using a Difference Expansion. Transactions on circuits and systems for video technology: AUGUST 2003; VOL. 13, NO. 8.
- [12] Siddharth Malik, Anjali Sardana, Jaya. A Keyless Approach to Image Encryption. International conference on Communication systems and Network Technologies: 2012; IEEE.
- [13] R. Vijayaraghavan, S. Sathya, N. R. Raajan. Security for an Image using Bit-slice Rotation Method–image Encryption. Indian Journal of Science and Technology: April 2014; Vol 7(4S); p 1–7.
- [14] C. Anuradha, S. Lavanya. Secure and Authenticated Reversible Data Hiding in Encrypted Image. International Journal of Advanced Research in Computer Science and Software Engineering: April 2013; volume 3, issue 4.
- [15] Zhicheng Ni, Yun-Qing Shi, Nirwan Ansari, Wei Su. Reversible Data Hiding. IEEE transactions on circuits and systems for video technology: March 2006; vol. 16, no. 3.
- [16] Asha S.N, Dr. Shreedhara. Performance Evaluation Of Extended Visual Cryptography Schemes With Embedded Extended Visual Cryptographic Scheme. International Journal of Scientific & Engineering Research: April-2012; Volume 3, Issue 4.
- [17] R. Lukac, K.N. Plataniotis. Bit-level based secret sharing for image encryption. The Journal of Pattern Recognition Society: 2005.
- [18] InKoo Kang, Gonzalo R. Arce, Heung-Kyu Lee. Color extended visual cryptography using error diffusion. IEEE: 2009.
- [19] Yi, Feng; Wang, Daoshun; Luo, Ping, Huang, Liansheng, Dai, Yiqi. Multi Secret Image Color Visual Cryptography Schemes for General Access Structures. April 2006; Volume 16, Number 4; pp. 431–436.
- [20] J. Fridrich, M. Goljan, and D. Rui. Lossless Data Embedding - New Paradigm in Digital Watermarking. In Special Issue on Emerging Applications of Multimedia Data Hiding: February 2002; Vol. 2; pp. 185–196.