

Review of High gain DC-DC Converter with Voltage Multiplier

Neha Agrawal¹, Tikeshwar Gajpal², Ritesh Diwan³

P.G. Student, Department of Electronics and Telecommunication Engineering, RITEE, Raipur, C.G., India¹

Assistant Professor, Department of Electronics and Telecommunication Engineering, RITEE, Raipur, C.G., India²

Associate Professor, Department of Electronics and Telecommunication Engineering, RITEE, Raipur, C.G., India³

ABSTRACT: A various number of conventional methods are proposed in recent year. Today research topic on pulse generation based approach for converter design. Photo voltaic (PV) system is used in recent era as a non conventional system. Where energy or power are generated and consume as required with the conversion of voltage or current. Therefore in this paper we provide classification, comparison of advantage and disadvantages of different technique used for step up converter for PV system. The photovoltaic system is essential for new era of energy sources utilization.

KEYWORDS: PV system, Pulse generation method, Voltage converter, steps up converter.

I. INTRODUCTION

Among renewable energy systems, photovoltaic systems are expected to play an important role in future energy production. Such systems transform light energy into electrical energy, and convert low voltage into high voltage via a step-up converter, which can convert energy into electricity using a grid-by-grid inverter or store energy into a battery set. The high step-up converter performs importantly among the system because the system requires a sufficiently high step-up conversion.

Renewable energies such as photovoltaic and fuel cells are becoming increasingly important and widely used in distribution systems. These kinds of energies address the solutions to environmental pollution and the problem of exhaust of fossil energy reserves. However, the main characteristics of these energies is the low-output voltage, then a DC-DC converter with large voltage conversion ratio is used to increase the output voltage of the clean energy for the DC interface to the main electricity source through the DC-AC inverter[1]. Typical applications are embedded systems, renewable energy systems, fuel cells, mobility applications and uninterrupted power supply (UPS). These applications demand high step-up static gain, high efficiency and reduced weight, volume and cost [2]. The high step-up conversion may require two-stage converters with cascade structure for enough step-up gain, which decreases the efficiency and increases the cost [6].

II. DC-DC CONVERTERS

DC-DC converters are linear regulator and switching choppers. They converts fixed DC to variable DC signal. Dc converters can be used in regenerative braking of dc motors to return energy back into the supply and this feature results in energy savings for transportation system with frequent stops. they also are used in conjunction with an inductor to generate a dc current source especially for the current source inverter.

Boost converter step-up converter: This circuit is used when a higher output voltage than input is required. While the transistor is ON $V_x = V_{in}$, and the OFF state the inductor current flows through the diode giving $V_x = V_o$. For this analysis it is assumed that the inductor current always remains flowing (continuous conduction). Since the duty ratio "D" is between 0 and 1 the output voltage must always be higher than the input voltage in magnitude. The negative sign indicates a reversal of sense of the output voltage.

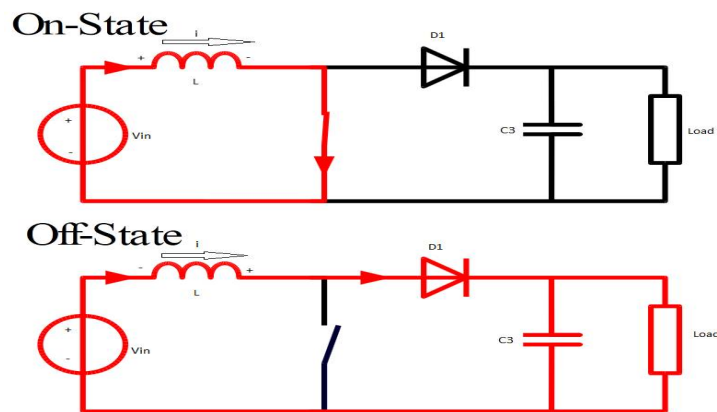

Figure 2.1: The Boost Converter Circuit

III. VOLTAGE MULTIPLIER

Voltage multiplier is a modified capacitor filter circuit that delivers a dc voltage twice or more times of the peak value (amplitude) of the input ac voltage. Such power supplies are used for high-voltage and low-current devices such as cathode-ray tubes (the picture tubes in TV receivers, oscilloscopes and computer display).

Voltage doubler: A Voltage Doublers is a voltage multiplier circuit which has a voltage multiplication factor of two. The circuit consists of only two diodes, two capacitors and an oscillating AC input voltage (a PWM waveform could also be used). This simple diode-capacitor pump circuit gives a DC output voltage equal to the peak-to-peak value of the sinusoidal input. In other words, double the peak voltage value because the diodes and the capacitors work together to effectively double the voltage.

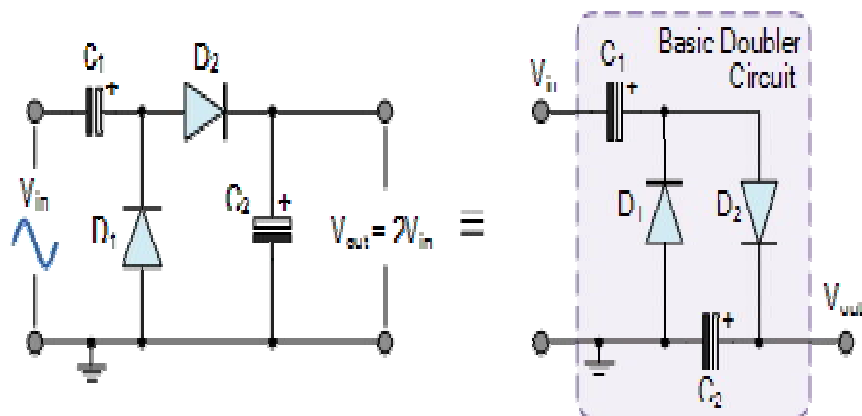

Figure 3.1: voltage doubler circuit.

IV. REVIEW ON DC-DC CONVERTERS FOR PV SYSTEMS

The surveys of various research papers that have contributed to achieve the high gain from lower output values obtained from renewable energy sources as photovoltaic system and also provide a guideline to work on this field.

International Journal of Innovative Research in Science, Engineering and Technology

(An ISO 3297: 2007 Certified Organization)

Website: www.ijirset.com

Vol. 6, Issue 4, April 2017

The comparison and analysis of various methods used for converter designs is described in the following subsections with their details:

Qun Zhao et al. developed a High-Efficiency, High Step-Up DC-DC Converters [1]. They have used Diodes and coupled windings instead of active switches to realize functions similar to those of active clamps. High step-up dc-dc converters not require isolation. Some dc-dc converters are provide high step-up voltage gain, but with the penalty of either an extreme duty ratio or a large amount of circulating energy [1].

S. Saggini et al. developed a Digital Deadbeat Control Tuning for dc-dc Converters Using Error Correlation. They have proposed a simple tuning algorithm for digital deadbeat control based on error correlation. The authors obtained by inject a square-wave reference input and calculate the correlation of the control error, a gain correction for deadbeat control [2].

Abbas A. Fardoun et al. developed a Ultra Step-Up DC-DC Converter with Reduced Switch. They have proposed a new single-switch non-isolated dc-dc converter with high-voltage transfer gain and reduced semiconductor voltage stress. The author utilize a hybrid switched capacitor technique for providing a high voltage gain without extreme switch duty cycle, the use of a lower voltage and RDS-ON MOSFET switch to reduce cost, switch conduction and turn-on losses. [3]

Li Tianze et al discussed Application and design of solar photovoltaic system. they have analyzed the design of PV system, software and hardware requirement, economic benefit, and basic ideas and steps of the installation and the connection of the system. Solar modules, power electronic equipments (include the charge-discharge controller), the inverter, the test instrumentation and the computer monitoring, and the storage battery or the other energy storage and auxiliary generating plant of the photovoltaic system [4].

Lung-Sheng Yang et al developed a Novel High Step-Up DC-DC Converter with Coupled-Inductor and Voltage-Doubler Circuits. The converter achieves high step-up voltage gain with appropriate duty ratio and low voltage stress on the power switches, and the energy stored in the leakage inductor of the coupled inductor are also recycled to the output [5].

S.Daison Stallon et al developed a High Efficient Module of Boost Converter in PV Module. they used a converter that employs a floating active switch to isolate energy from the PV panel when the ac module is OFF, a high voltage gain converter is essential for the module's grid connection through a dc-ac inverter. This design protects installers and users from electrical hazards. They suggested that without extreme duty ratios and the numerous turns-ratios of a coupled inductor, this converter achieves a high step-up voltage-conversion ratio; the leakage inductor energy of the coupled inductor is efficiently recycled to the load [6].

Sheng-Yu Tseng et al. developed A Photovoltaic Power System Using a High Step-up Converter for DC Load Applications. they have used a power system with a high step- up converter for dc load applications. The high step-up converter adopts a boost converter with interleaved mode and a coupled inductor to raise its powering ability and increase its step-up voltage ratio, for increase conversion efficiency, an active clamp circuit is used into the soft-switching to reduce switching losses. Switches in the converter and active clamp circuit were integrated with a synchronous switching technique to reduce circuit complexity and component counts, in a lower cost and smaller volume. A perturb and observe method is adopted for extract the maximum power from photovoltaic (PV) arrays and a microchip associated with PWM IC is also used to implement maximum power point tracking operation, voltage regulation and power management.[7].

Nalini.N et al. developed a Step-Up DC-DC Converter Using Zero-Voltage Switching Boost Integration Technique in PV and All Renewable Battery Systems. They used the non-isolated high step-up DC-DC converter using Zero Voltage Switching (ZVS) Bi-directional Integration Technique (BIT). The DC-DC converter used which integrates PV and battery power for high step up. Coupled inductors were also used to attain the high step up voltage gain and to reduce the voltage stress of input side switches [8].

Pulipati Madhuri et al. developed an Integrated dc-dc converter for high voltage gain. they used a novel single-switch high step-up non isolated dc-dc converter integrating coupled inductor with extended voltage doubler cell and diode-capacitor techniques. The energy stored in leakage inductance of coupled inductor are efficiently recycled to the output, which alleviating the problem of potential resonance between the leakage inductance and the junction capacitor of output diode [9].

International Journal of Innovative Research in Science, Engineering and Technology

(An ISO 3297: 2007 Certified Organization)

Website: www.ijirset.com

Vol. 6, Issue 4, April 2017

M. Vignesh et al. developed a High Gain Voltage DC-DC Converter based on Three State Switching Cell for Battery Charging using PV system, a grid-connected PV system with high ZVT interleaved boost converter was taken, The grid-connection of PV control system added two operating stages a ZVT converter for boosting a low voltage of PV panel array up to the high voltage DC bus which is not lower than the grid level voltage and a bridge inverter for inverting the current into a sinusoidal waveform adjust with grid side. In addition, the boost converter is subject for the MPPT Techniques and the inverter for stabilizing the voltage of DC bus to a exact value. The ZVT interleaved boost converter with capacitors-clamp circuit can give high voltage gain and guarantee PV voltage is lower than 60V, while the power system in combine the utility grid side. Thus the power can be maintained in a large range the quantity of PV module.[10]

Rafael V. Silva et al. developed a High Gain QZS DC/DC Converter With Coupled Inductor. They used a non-isolated QZS converter to feed a frequency inverter applied on a standalone photovoltaic tricycle. The converter use the clipping voltage of the power switch and add to the output voltage, which allows to reducing the duty cycle values and increase the gain of the converter, as a consequence the lifespan of the components and the converter efficiency are reduced. This technique has a low current ripple in the input and the power switch was submitted to lower voltage. [11]

Table 1. Comparative study of different researchers

S. N	TITLE	PUBLICATION & YEAR	AREA/APPLICATION	METHODOLOGY USED	DESCRIPTION	
					ADVANTAGES	LIMITATIONS
1	A high step-up converter with a voltage multiplier Module for a photovoltaic system	IEEE TRANSACTIONS ON POWER ELECTRONICS , 2003	PV Systems	Asymmetrical interleaved high step-up converter	Less conduction loss and cost	High Duty ratio
2	A High Voltage Gain DC-DC Converter Integrating Coupled-Inductor and Diode-Capacitor Techniques	IEEE TRANSACTIONS ON POWER ELECTRONICS , 2007	Photovoltaic Systems, Fuel Cell systems	Nonisolated DC-DC Converter integrating coupled inductor	Large Voltage Conversion Ratio	Switching Frequency Must Be Maintained Constant
3	Nonlinear Modeling of DC/DC Converters Using the Hammerstein's Approach	IEEE TRANSACTIONS ON POWER ELECTRONICS , 2008	Modeling of highly nonlinear Switching power-electronics converters	Black-box Identification methods	Good degree of accuracy	PID controller required
4	Graphical Analytical Method for Power DC-DC Converters: Averaging Binary Tree Structure Representation	IEEE TRANSACTIONS ON POWER ELECTRONICS , 2010	DC-DC converters	averaging binary tree structure	Simplified tree structure for modeling of converter	High duty ratio

International Journal of Innovative Research in Science, Engineering and Technology

(An ISO 3297: 2007 Certified Organization)

Website: www.ijirset.com

Vol. 6, Issue 4, April 2017

5	Ultra Step-Up DC-DC Converter with Reduced Switch	ICSET,2011	PV system	Hybrid Switched Capacitor Technique	Reduce cost, switch conduction and Turn-on losses.	Complex Circuit, High Ripple
6	Voltage Multiplier Cells Applied to Non-Isolated DC-DC Converters	IEEE TRANSACTIONS ON POWER ELECTRONICS , 2012	PV system	non-isolated dc-dc converters with voltage multiplier	Diodes reverse Recovery current problem is minimized	Switching Frequency Must Be Maintained Constant
7	Novel High Step-Up DC-DC Converter with Coupled-Inductor and Voltage-Doubler Circuits	IEEE, 2013	PV system	Coupled-Inductor And Voltage-Doubler	Low Voltage Stress On The Power Switches	Reverse Recover And Voltage Spikes
8	Analysis and Design of High Step-Up DC-DC Converter for Photovoltaic Application	IOSR JOURNAL OF ELECTRICAL AND ELECTRONICS ENGINEERING (IOSR-JEEE), 2014	PV systems	High Step Up Dc-Dc Converter With Floating Active Switch	Full load efficiency is better	Voltage Balancing, Snubber Circuit Required
9	Interleaved high step-up DC-DC converter based on three-winding high-frequency coupled inductor and voltage multiplier cell	IET POWER ELECTRONICS ,2015	Photovoltaic Systems	Three-winding high-frequency coupled Inductor	Moderate gain	Reverse Recovery Problem
10	Comparative Study Of Self-Lift Dc-Dc Converters With High Voltage Gain	INTERNATIONAL JOURNAL OF ENGINEERING RESEARCH AND GENERAL SCIENCE,2016	DC distributed power Systems	Enhanced Self-Lift Cuk Converter And Self-Lift Luo Converter	Very Small In Size And High In Power Density	complexity
11	High gain QZS DC-DC converter with Coupled inductor	IEEE, 2016	A Standalone Photovoltaic Tricycle	Non-Isolated QZS Converter	Reduced The Duty Cycle Values And Increase The Gain Of The Converter	High Losses Related To Coupled Inductor

International Journal of Innovative Research in Science, Engineering and Technology

(An ISO 3297: 2007 Certified Organization)

Website: www.ijirset.com

Vol. 6, Issue 4, April 2017

V. CONCLUSION

For enhancing the voltage gain various technique have used by various researchers.

The researchers have investigated and study the following methods:

- 1) Boost Converter: The conventional boost converter provide step up conversion without high gain due the limitation of conduction losses in the circuit parameters. The gain reaches infinite, when the duty cycle tends to unity. The gain depends on the I^2R losses in the inductors and the power electronic devices connected. The voltage gain is difficult to obtain with conventional boost topologies because of the parasitic components, which limits the frequency and the system size.
- 2) Buck Boost Converter: The proposed topology consist of one inductor, 2N-1 Diodes, 2N-1 Capacitors and single switch for N level dc-dc boost converter. The limitation is it operated at high duty ratio.
- 3) Coupled Inductors: the disadvantages of this method were reverse recovery problem and voltage spikes. The advantage of recycling of leakage current was discussed in this method.
- 4) Interleaved technique: it helped to achieve high gain but high ripple current, high ringing of voltage at switches was the disadvantages found with this method.
- 5) Boost Converter with Active clamp method: provides higher gain but complex structure and voltage balancing problem were the limitation of this method.
- 6) Cock Croft Walton Multiplier: Cockcroft Walton (CW) voltage multipliers are used in application where high gain required. The circuit consists of inductor, switches, n-stage voltage multipliers. One of the diode in CW conducts when the inductor transfers energy to the circuit. The voltage across the output is equal to the voltages across the capacitors at the bottom. The voltage stresses in the diodes are twice than that of the switches. They operate in continuous conduction mode. The advantages are the four switches are operating at two different frequencies. The dc outputs from capacitors are suitable for powering multilevel inverters. The limitations of the topology are the complexity and cost to drive the power semiconductor switches.
- 7) Three Switching State Voltage Multiplier: The three state switching cell are incorporated with the voltage multiplier for improving the gain. The advantage of using this topology of converter is the reduced number of components, weight and volume of the circuit. The current flowing through the switch is same as the output current. The energy flow is from source to the load during the switching period. The advantage of this topology is low current ripple and voltage stress. The output of the system can be improved by adjusting the turns ratio of transformer used. The three state switching cells are used to reduce the winding size of the converter. The performance of the converter is high for all the value of input voltages. This reduces the transformer saturation problem and conduction losses by the leakage inductances the limitation of the converter is the complex drive circuit requirement. Small snubber circuits are provided in the circuit for each switch. The circuits are provided with hard commutation. The voltage multiplier is working at $d > d_{min}$. It has seen that the time taken by other methods for achieving maximum voltage and current point is high. In proposed technique by using voltage clamping technique with pulse generation the time interval can be minimize. The losses across switch are minimized in the proposed technique with achieving higher gain at lower duty ratio.

REFERENCES

- [1] Zhao, Qun, and Lee, Fred C., "High-Efficiency, High Step-Up DC-DC Converters", IEEE Transactions on power electronics, Vol. 18(1), 2003.
- [2] Saggini, S., Stefanutti, W., Tedeschi, E. and Mattavelli, Paolo, "Digital Deadbeat Control Tuning for dc-dc converters Using Error Correlation", IEEE transactions on power electronics, Vol. 22(4), 2007
- [3] Abbas, A. Fardoun, and Ismail, Esam H., "Ultra Step-Up DC-DC Converter with Reduced Switch" ICSET, 2008.
- [4] Tianze, Li., Hengwei, Lu., Chuan, Jiang., Luan, Hou., and Xia, Zhang., "Application and design of solar photovoltaic system", 3rd International Photonics & OptoElectronics Meetings (POEM), 2010.
- [5] Yang , Lung-Sheng., Liang, Tsorng-Juu., Lee, Hau-Cheng Lee, and Chen, Jiann-Fuh., "Novel High Step-Up DC-DC Converter with Coupled-Inductor and Voltage-Doubler Circuits", IEEE Transactions on Industrial Electronics, Vol. 58(9), 2011.
- [6] Stallon, S.Daison, Kumar, K.Vinoth, and Kumar, S.Suresh, "High Efficient Module of Boost Converter in PV Module", IJECE, Vol.2, pp. 758-781, 2012.



ISSN(Online) : 2319-8753
ISSN(Print) : 2347-6710

International Journal of Innovative Research in Science, Engineering and Technology

(An ISO 3297: 2007 Certified Organization)

Website: www.ijirset.com

Vol. 6, Issue 4, April 2017

- [7] Tseng, Sheng-Yu, and Wang, Hung-Yuan, "A Photovoltaic Power System Using a High Step-up Converter for DC Load Applications", *Energies* 6(2), Pp 1068-1100, 2013.
- [8] Nalini.N, and SheelaSankari, Ms.M., "Step-Up DC-DC Converters Using Zero-Voltage Switching Boost Integration Technique in PV and All Renewable Battery Systems", *International Journal of Innovative Research in Science, Engineering and Technology*, Vol. (1)3, 2014
- [9] Madhuri, Pulipati., and Ramesh, Daravath., "Integrated dc-dc converter for high voltage gain", *Transactions on advances in power electronics*, Pp 327-343, 2015
- [10] Vignesh, M., Abirami, G., " High Gain Voltage DC-DC Converter based on Three State Switching Cell for Battery Charging using PV system", *IJREE*, Vol. 03(01), 2016.
- [11] Silval, Rafael V., Freitas, Antônio A. A., Castro, Marcus R., Antunes, Fernando L. M., and Edilson M. Sá Jr., "High gain qzs dc/dc converter with coupled inductor", *Power Electronics Conference and 1st Southern Power Electronics Conference 2015, IEEE 13th Brazilian*. 2016