

Performance Comparison of Conventional and Microchannel Condenser in Vapour Compression Refrigeration System

Tejas Pawar ¹, Ajay Kulkarni ², Gaurav Kulkarni ³, Sumit Patil ⁴, Jagdip Yadav ⁵, Vivekanand Shikalgar ⁶

U.G. Student, Department of Mechanical Engineering, SBGI Engineering College, Miraj-Sangli road, Maharashtra, India ^{1,2,3,4,5}

Assistant Professor, Department of Mechanical Engineering, SBGI Engineering College, Miraj-Sangli road, Maharashtra, India ⁶

ABSTRACT: The microchannel condenser is required less space as compared to regular condenser and it also required less amount of refrigerant. The more surface area is available to reject the heat to surrounding air as thin tubes are used in micro channel condenser. The purpose of the present study is to develop a setup of a refrigeration system with micro channel condenser, Performance comparison of conventional and micro channel condenser. For its performance, refrigeration set up to detect experimental performance of microchannel condenser. In this paper performance analysis of microchannel condenser compared with coil tube. In analysis of micro channel condensers it can be found more effective at various loads and operating conditions. For review same size of micro channel and round tube condenser are considered. Also C.O.P & Efficiency of microchannel the various reviews of reviewer micro channel condenser can be efficient and also refrigerator system requires less power

KEYWORDS: Microchannel condenser, Refrigeration, Round tube condenser, COP, Efficiency

I. INTRODUCTION

Refrigeration is one of the most important aspects of Thermal Engineering. The term refrigeration may be defined as the process of removing heat from a substance or a space under controlled conditions. It also includes the process of reducing and maintaining the temperature of a body below the general temperature of its surroundings. There are many applications of refrigeration in our daily life. It can be done by various ways like vapour compression, absorption, adsorption depends on application and availability. In simple vapour compression as shown in Fig.1 system refrigerant is used for cooling and components are compressor, condenser, expansion device and evaporator, Fig.2 & fig.3 shows T-S and p-h diagrams respectively. According to the requirement, vapour compression system is further modified for better performance and control. Such systems are compound systems, cascade systems and multi evaporator systems.

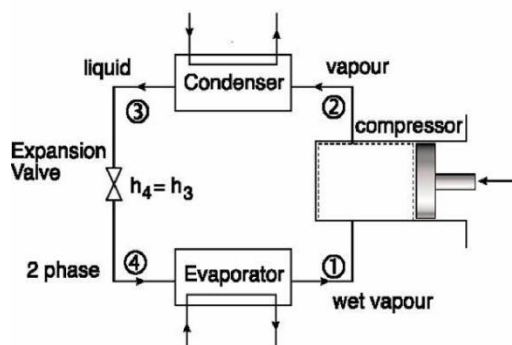

Fig.1

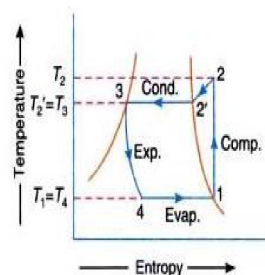

Fig.2

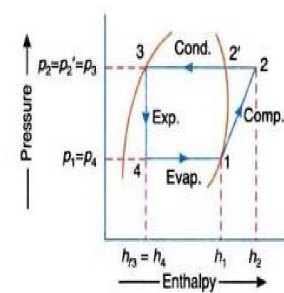

Fig.3

International Journal of Innovative Research in Science, Engineering and Technology

(An ISO 3297: 2007 Certified Organization)

Website: www.ijirset.com

Vol. 6, Issue 4, April 2017

Some commercial refrigerating systems have one tube type condenser which utilize more space and also require more amount of refrigerant. In refrigeration system condenser is used to reject the latent heat to the atmospheric air. The condenser is one of the important parts of the system. The micro channel condenser is required less space as compared to regular condenser and it also required less amount of refrigerant. The more surface area is available to reject the heat to surrounding air as thin tubes are used in microchannel condenser.

The literature review is carried out in order to see the present research in this area which is elaborated under the present status. Further review will be carried out for the following purpose by referring journals like International Journal of Refrigeration, Applied Thermal Engineering, ASHRAE Journal, Renewable and Sustainable Energy Review, Journal of Industrial and Scientific Research etc. Many researchers have attempted experimental and theoretical work on micro channel condenser some of this work is focused on the use of micro channel condensers in Refrigeration System.

Qian Sub[1] reported short communication on Microchannel condensation : Correlations and theory Attention is drawn, to the fact that, while four different correlations for condensation in Micro channels are in fair agreement for the case of R134a (on which the empirical constants in the correlations are predominately based) they differ markedly when applied to other fluids such as ammonia. A wholly theoretical model is compared with the correlations for both R134a and ammonia.

Liang-Liang Shaoa[2] presented Numerical modeling of serpentine microchannel condensers. Microchannel (or mini-channel) heat exchangers are drawing more attention because of the potential cost reduction and the lower refrigerant charge. Serpentine microchannel heat exchangers are even more compact because of the minimized headers. Using the serpentine microchannel condenser, some thermodynamically good but flammable refrigerants like R-290 (Propane) can be extended to more applications. To well size the serpentine microchannel condensers, a distributed-parameter model has been developed in this paper. Airside mal distribution is taken into account. Model validation shows good agreement with the experimental data. The predictions on the heating capacity and the pressure drop fall into 10% error band. Further analysis shows the impact of the pass number and the airside mal distribution on the condenser performance.

Gunda Mader[3] Presented Comparison of the transient behaviour of microchannel and fin-and-tube evaporators. The development of control algorithms for refrigeration systems requires models capable of simulating transient behaviour with sensible computational time and effort. The most pronounced dynamics in these systems are found in the condenser and the evaporator, especially the transient behaviour of the evaporator is of great importance when designing and tuning controllers for refrigeration systems. Various so called moving boundary models were developed for capturing these dynamics and showed to cover the important characteristics. A factor that has significant influence on the time constant and nonlinear behaviour of a system is the amount of refrigerant charge in the evaporator which is considerably reduced when microchannel heat exchangers are utilized. Here a moving boundary model is used and adapted to simulate and compare the transient behaviour of a microchannel evaporator with a fin-and-tube evaporator for a residential air-conditioning system. The results are validated experimentally at a test rig.

J.R.Garcia-Cascales[4] Presented Compact heat exchangers modeling: Condensation a model for the analysis of compact heat exchangers working as either evaporators or condensers is presented. This paper will focus exclusively on condensation modeling. The model is based on cell discretization of the heat exchanger in such a way that cells are analysed following the path imposed by the refrigerant flowing through the tubes. It has been implemented in a robust code developed for assisting with the design of compact heat exchangers and refrigeration systems. These heat exchangers consist of serpentine fins that are brazed to multi-port tubes with internal microchannels. This paper also investigates a number of correlations used for the calculation of the refrigerant side heat transfer coefficient. They are evaluated comparing the predicted data with the experimental data. The working fluids used in the experiments are R134a and R410A, and the secondary fluid is air. The experimental facility is briefly described and some conclusions are finally drawn.

Pega Hrnjak[5] Reported Microchannel heat exchangers for charge minimization in air-cooled ammonia condensers and chillers This paper presents experimental results from a prototype ammonia chiller with an air-cooled condenser and a plate evaporator. The main objectives were charge reduction and compactness of the system. The charge is reduced to 20 g/kW (2.5 oz/Ton). This is lower than any currently available air-cooled ammonia chiller on the market. The major contribution comes from use of microchannel aluminium tubes. Two aluminium condensers were evaluated in the chiller: one with a parallel tube arrangement between headers and "microchannel" tubes (hydraulic

International Journal of Innovative Research in Science, Engineering and Technology

(An ISO 3297: 2007 Certified Organization)

Website: www.ijirset.com

Vol. 6, Issue 4, April 2017

diameter $D_h \frac{1}{4}$ 0.7 mm), and the other with a single serpentine ‘macrochannel’ tube ($D_h \frac{1}{4}$ 4.06 mm). The performances of the chiller and condensers are compared based on various criteria to other available ammonia chillers. This prototype was made and examined in the Air Conditioning and Refrigeration Center in 1998, at the University of Illinois at Urbana-Champaign.

II. RELATED WORK

This system shows that two condenser is used for experimentation purpose. One regular tubed condenser is used for condensation and parallel microchannel condenser is used for our experimentation purpose. This layout in Fig.4 shows the modification in existing vapour compression refrigeration system. At the time of test only one condenser will be working. During the test first regular tubed condenser will be used for condensation purpose and test will be conducted. Later on refrigerant will flow through microchannel condenser. The direction of refrigerant flow will be control by using direction control valve. Rotameter is used to measure the mass flow rate of refrigerant after condensation, which will be used to calculate heat removed by system. P-H diagram represent the ideal condition of system.

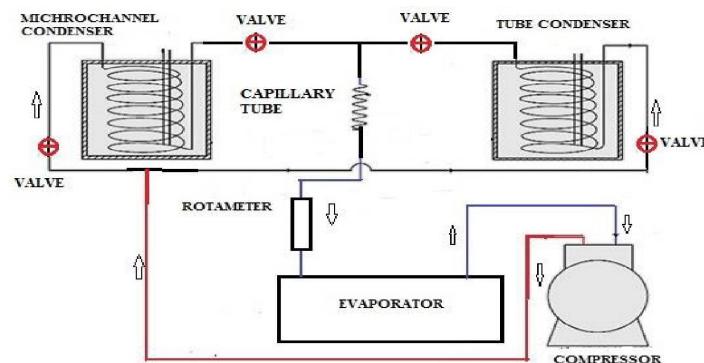

Fig.4. Layout of Proposed setup

III. EXPERIMENTATION

The experimental setup of system is shown in Fig.5. The following procedure is followed to conduct the experimentation

1. Start the main switch.
2. Start Compressor and fan
3. Check the direction of refrigerant flow
4. Set the flow initially to tubed condenser with the help of direction control valve. Open both direction control valve on tubed condenser flow line and closed the valve on Microchannel condensed flow line.
5. Check the load on evaporator. Apply load 20 kg initially.
6. Note the reading for initial temperature of water in evaporator.
7. Again, take the reading when temperature of water in evaporator decreased by 2° C.
8. Continue step 7 for eight readings.
9. Repeat step 5 to 8 for others load on evaporator i.e. 25 kg and 30 kg.
After completion of this test for tubed condenser closed both the refrigerant flow control valve on tubed condenser and open the valve on microchannel condenser side.
10. Repeat step 5 to 9 for microchannel condenser

International Journal of Innovative Research in Science, Engineering and Technology

(An ISO 3297: 2007 Certified Organization)

Website: www.ijirset.com

Vol. 6, Issue 4, April 2017



Fig.5. Experimental Setup

IV. OBSERVATION

The following output readings are measured during experimentation as shown below. The eight readings are taken for each successive load. The experiment carried out alternately for tubed and micro channel condenser i.e. during experimentation if want to take readings of tubed condenser we have to close the micro channel condenser and vice versa. The operating condition of system is at atmospheric pressure. Total time required for the experimentation is 33 min.

- T1= Temperature after compressor
- T2= Temperature after condenser
- T3= Temperature before evaporator
- T4= Temperature after evaporator
- T5= Temperature of load (inside the evaporator)
- P1= Pressure of delivery line (Compressor pressure)
- P2= Pressure of suction line (Evaporator pressure)

Table.1. Experimental Observations

Tubed Condenser for 20 Kg Load										
Sr. No.	Refrigerant Temp 0C				Water Temp 0C	Pressure (psi)		Refrigerant Flow Rate	Energy Meter (kWh)	Time required for cycle (min)
	T1	T2	T3	T4	T5	P1	P2	LPH		T
1	37	29	16	39	28	120	13	01	3.22	33
2	44	33	16	39	26	125	14	01	-	
3	46	35	15	37	24	131	15	01	-	
4	53	38	15	36	22	131	17	01	-	
5	59	40	14	36	20	138	18	01	-	
6	67	43	14	35	18	145	21	01	-	
7	69	45	13	35	16	170	22	01	-	
8	75	48	13	34	14	195	23	01	3.66	

International Journal of Innovative Research in Science, Engineering and Technology

(An ISO 3297: 2007 Certified Organization)

Website: www.ijirset.com

Vol. 6, Issue 4, April 2017

V. CALCULATION

I) For tube type condenser
For 20 kg load

$$\begin{aligned} h_1 &= 392 \text{ kJ/kg} \\ h_2 &= 449 \text{ kJ/kg} \\ h_3 &= h_4 = 270 \text{ kJ/kg} \end{aligned}$$

$$\text{Cop experimental} = \frac{\text{refrigeration effect}}{\text{compressor work}} = \frac{h_1 - h_4}{h_2 - h_1} = \frac{392 - 270}{449 - 392} = 2.10$$

$$\text{Cop theoretical} = \frac{m \cdot C_p \cdot \Delta T}{\text{energy meter reading} \times \text{time}} = \frac{20 \times 4.14 \times 14}{0.44 \times 60 \times 33} = 1.33$$

II) For Micro channel condenser
For 20 kg load

$$\begin{aligned} h_1 &= 392 \text{ kJ/kg} \\ h_2 &= 447 \text{ kJ/kg} \\ h_3 &= h_4 = 294 \text{ kJ/kg} \end{aligned}$$

$$\text{Cop experimental} = \frac{\text{refrigeration effect}}{\text{compressor work}} = \frac{h_1 - h_4}{h_2 - h_1} = \frac{390 - 294}{447 - 390} = 1.68$$

$$\text{Cop theoretical} = \frac{m \cdot C_p \cdot \Delta T}{\text{energy meter reading} \times \text{time}} = \frac{20 \times 4.14 \times 20}{0.42 \times 60 \times 28} = 2.34$$

VI. RESULT AND DISCUSSION

Experimental setup is as shown in fig.5 we have taken the eight readings for each loading conditions. The loads considered during experimentation are 20Kg, 25 Kg, and 30 Kg respectively. The table .2 shows all the readings during experimentation for respective loadings.

Table.2. Experimental Results

For tube type condenser Theoretical COP		
Load 20 kg	Load 25 kg	Load 30 kg
2.91	2.50	2.42
2.87	2.43	2.36
2.85	2.39	2.33
2.62	2.33	2.26
2.42	2.29	2.15
2.27	2.26	2.11
2.13	2.25	2.05
2.10	2.21	1.98
For Micro channel condenser Theoretical COP		
Load 20 kg	Load 25 kg	Load 30 kg
2.64	3.21	3.19
2.57	3.10	3.11
2.51	2.99	2.93
2.45	2.81	2.87
2.41	2.75	2.77
2.37	2.63	2.67
2.33	2.55	2.53
2.30	2.48	2.41

International Journal of Innovative Research in Science, Engineering and Technology

(An ISO 3297: 2007 Certified Organization)

Website: www.ijirset.com

Vol. 6, Issue 4, April 2017

In this graph (as shown in Fig.6), on the abscissa types of loads are shown and on the ordinate COP are shown. From this it is clear that cop of microchannel condenser is greater than the COP of tubed type (conventional) condenser. When we apply 25kg load on the system then we got higher COP 2.48 for microchannel condenser and for tube type condenser 2.21, and for 20kg load COP of microchannel condenser is 2.30 and for tube condenser 2.10. For 30kg load COP for microchannel condenser is 2.41 and for tube condenser is 1.98.

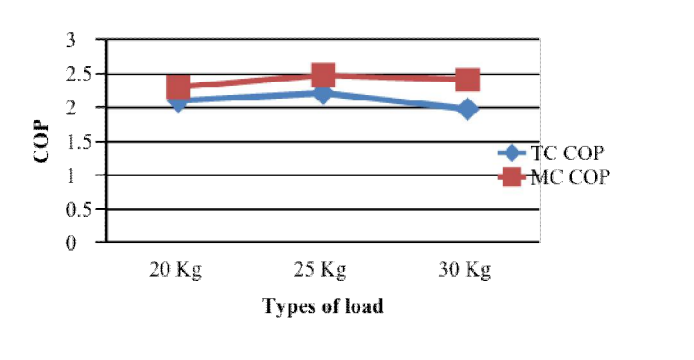

Fig.6.Comparison of result

Here we get higher COP for 25kg load on both microchannel condenser and tube condenser. This is because of all coils of evaporator coil are contact with load. COP of microchannel condenser is higher than the COP of tube condenser because sub-cooling is takes place in microchannel condenser for same compressor work. Hence refrigerating effect increases.

VII. CONCLUSION

During this project we compare the COP of the tube type condenser and microchannel condenser. We find that the COP of microchannel condenser is higher than that of COP of tubed type condenser for each load on refrigeration system. When using microchannel condenser sub-cooling of refrigerant takes place and refrigeration effect get increases for same compressor work, hence we got higher COP for Microchannel condenser than tube type condenser.

During the test we get maximum COP for 25kg load i.e. 2.48 for microchannel condenser and 2.21 for tube type condenser.

This is due to all evaporator coil are in contact with the load hence the COP for both cases for microchannel and tube type condenser is higher, and in case of 30kg load we get COP 2.41 for microchannel condenser and 1.98 for tube type condenser, and for 20kg load we get COP 2.30 for microchannel condenser and 2.10 for tube type condenser. During experiment we observe that the theoretical COP of each load is higher at initial stage and it goes on decreasing for final stage because initially refrigeration effect is more and compressor work is less, as process proceeds refrigeration effect goes on decreasing and compressor work goes on increasing.

REFERENCES

- [1] Qian Sub, Guang Xu Yua, Hua Sheng Wanga, John W. Rose, "Short Communication On Microchannel Condensation Correlations And Theory", International Journal of Refrigeration, Vol. 32, pp. 49- 52, 2009.
- [2] Liang-Liang Shao, Liang Yang Chun-Lu Zhang, Bo Gu, "Numerical modeling of serpentine microchannel condensers", International Journal of Refrigeration, Vol. 32, pp. 62- 72, 2009.
- [3] Gunda Mader, Georg P.F. Fosel, Lars F.S. Larsen, "Comparison Of The Transient Behavior Of Microchannel And Fin-And-Tube Evaporators", International Journal of Refrigeration, Vol. 34, pp. 222- 229, 2011.
- [4] J.R. Garcia-Cascales, F. Vera-Garcia J. 'Gonzalvez-Macia, J.M. Corberan-Salvador, M.W. Johnson, G.T. Kohler, "Compact heat exchangers modeling: Condensation", International Journal of Refrigeration, Vol. 33, pp.135- 147, 2010.
- [5] Pega Hrnjak, Andy D. Litch, "Microchannel heat exchangers for charge minimization in air-cooled ammonia condensers and chillers", International Journal of Refrigeration, Vol. 31, pp. 658- 668,2011.