

Fuzzy Based Maximum Power Point Tracking in Transformer Less Grid Connected PV system

Ramadas.K¹, Anusiya.K²

Assistant Professor, Department of Electrical and Electronics Engineering, Alagappa Chettiar College of Engineering and Technology, Karaikudi, Tamil Nadu, India¹

P.G. Student, Department of Electrical and Electronics Engineering, Alagappa Chettiar College of Engineering and Technology, Karaikudi, Tamil Nadu, India²

ABSTRACT: This paper is aimed implementation of a Fuzzy Based Maximum Power Point Tracking in Transformer less Grid Connected PV System A single diode model is used for PV array and simulation study is performed using MATLAB. In the fuzzy logic controller, voltage and current are taken as inputs and the effective value of A.C current corresponding to the maximum power point is the output. This results in utilization of PV system at night and at periods of low irradiation. Rules relating the input and output of Fuzzy Logic Controller are written and simulation is performed. A DC-DC Single Ended Primary Inductor Converter (SEPIC) is used for maintaining DC input to the inverter at various conditions of irradiation and temperature. Gating pulses to the inverter are generated by PI (Proportional integral) controller. Simulation model of a 1000W solar panel is developed and results are obtained with Fuzzy logic controller for different irradiation and temperature conditions. Results show the effectiveness of the proposed method in utilizing the PV system.

KEYWORDS: PV system, Maximum Power Point, Irradiation, Reactive Power, Transformer less Grid connected, Fuzzy Logic Controller, PI Controller.

I. INTRODUCTION

Photovoltaic (PV) energy is currently considered to be one of the most useful natural energy sources because it is free, abundant, pollution-free, and distributed throughout the Earth. Since Voltage and Current of a PV system are interdependent, for a given value of irradiation and temperature, there is only one value of load at which maximum power is extracted from the PV system. Various Maximum power point tracking (MPPT) methods [4]-[15] are used to extract the maximum possible power from the PV array, such as the lookup table method [14]-[17], perturb and observe method [14],[15] and incremental conductance method [12],[13]. Incremental conductance method is most accurate among the above methods and provides good performance under rapidly changing conditions. There are literatures on MPPT using Soft Computing Techniques like Fuzzy Logic and Neural Networks [6],[7] In this paper, fuzzy logic controller based MPPT is used because of its advantages such need for approximate data with cost effective sensors. The Fuzzy algorithms are quite understandable, robust, in the sense that they are not very sensitive to changing environments and erroneous or forgotten rules. Recent literatures show that in addition to Real Power (P) injection, inverter of PV system is controlled to inject Reactive Power (Q) thereby increasing the utility of the PV system at periods of low irradiation.

II. BLOCK DIAGRAM DESCRIPTION

The block diagram of a Fuzzy Logic Based Transformer less Grid Connected PV System is given in figure. Fig.1. In the fuzzy logic controller, the input variables are the voltage and current. The SEPIC converter allows a range

International Journal of Innovative Research in Science, Engineering and Technology

(An ISO 3297: 2007 Certified Organization)

Website: www.ijirset.com

Vol. 6, Issue 8, August 2017

of dc voltage to be adjusted to maintain a constant voltage output. DC-DC converters operate by rapidly turning on and off a MOSFET, generally with a high frequency pulse. The FUZZY Logic controller feedback loop should be able to increase the duty cycle to raise the output when the output is too low and decrease it when the output is too high. To do this, the output will need to be compared to a reference voltage which remains constant even if the input changes. The error between the output and the reference is added to a set bias voltage. The resulting voltage is then used as the control voltage for PWM. When the output is too low, the amplified error increases which causes the control voltage to increase. The increase in control voltage increases the duty cycle until the output is correct.

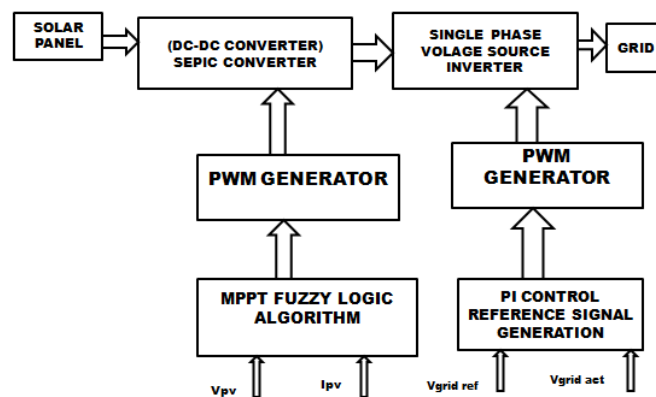

Fig.1 Block diagram of SEPIC Converter based Transformer less grid connected PV system with Reactive Power Compensation using FLC Based MPPT.

The duty cycle (D) is used to drive the SEPIC converter so that input voltage to the inverter is maintained constant. The inverter output is directly connected to the grid line without transformer for reactive power compensation. Grid active and reactive power is measured by a measurement block. Output is given to the PI controller. Here Function of PI controller is reduce the error corresponding to the carrier signal for generating the pulse to the inverter.

III. OPERATION AND CONTROL

A. Modelling of solar array^{[16],[17]}

Solar panel is simulated using one diode model. From the equivalent circuit of one diode model, it is evident that the current produced by the solar cell is equal to that produced by the current source, minus that which flows through the diode, minus that which flows through the shunt resistor:

$$I = I_{ph} - I_D - I_{sh} \quad (2)$$

Where I = output current (ampere), I_{ph} = photovoltaic current (ampere), I_D = diode current (ampere), I_{sh} = shunt current (ampere). The photovoltaic current is generated by the following equation:

$$I_{ph} = \frac{G}{G_{ref}} (I_{sc,ref} + \mu_{sc} \cdot \Delta T) \quad (3)$$

where, G = irradiation (Watt/m²), G_{ref} = irradiation at STC (Watt/m²) = 1000 W/m², $I_{sc,ref}$ = reference short circuit current (ampere), μ_{sc} = temperature coefficient (A/k), $\Delta T = T - T_{ref}$, T = Temperature (kelvin), T_{ref} = Temperature at STC (kelvin) = 25 + 273 = 298 K. By the [Shoectkey diode equation](#), the current through the diode (I_D) is:

$$I_D = I_0 \left(\exp \left(\frac{V + I R_s}{\alpha} \right) \right) \quad (4)$$

International Journal of Innovative Research in Science, Engineering and Technology

(An ISO 3297: 2007 Certified Organization)

Website: www.ijirset.com

Vol. 6, Issue 8, August 2017

Here,

$$I_0 = I_{0,ref} \left(\frac{T}{T_{ref}} \right)^B \exp \left[\left(\frac{qE_g}{A.k} \right) \left(\frac{1}{T_{0,ref}} - \frac{1}{T_0} \right) \right] \quad (5)$$

$$I_{0,ref} = I_{sc,ref} \exp \left(\frac{-V_{oc,ref}}{a} \right) \quad (6)$$

where, I_0 =reverse saturation current of the diode(ampere), q =Charge of electron= 1.6021×10^{-19} coulombs, E_g =Band gap Energy= 1.12eV for silicon, A =ideality factor= 1.3 , K =Boltzmann's constant = 1.3806×10^{-23} J/K, V_{oc} =Open circuit voltage= 21.8 V

$$a = \frac{N_s + A + k + T_c}{q} \quad (7)$$

where, 'a' is the "modified ideality factor" and is considered as a parameter to determine, and 'A' is the diode ideality factor^[1]. Substituting these into the first equation produces the characteristic equation of a solar cell, which is given by

$$I = I_{ph} - I_0 \left[\exp \left(\frac{V + IR_s}{a} \right) \right] - I_{sh} \quad (8)$$

The panel specifications are tabulated in table.1

Table.1 Parameters for 100W solar panel

S.NO	PARAMETERS	VALUES
1	No.of solar cells in series, N_s	36
2	Boltzmann's constant, K	1.3806×10^{-23}
3	Irradiance, $G_{ref}(W/m^2)$	1000
4	Short circuit current, $I_{sc}(A)$	6.22
5	Open circuit voltage, $V_{oc}(V)$	21.6
6	Band gap Energy, E_g	1.12
7	Charge of electron, q	1.6021×10^{-19}
8	Ideality factor, A	1.3
9	Temperature, $T_{ref}(K)$	298
10	Coefficient of temperature, μ_{sc}	0.0013
11	Series Resistance, $R_s(\Omega)$	0.45
12	Shunt Resistance, $R_p(\Omega)$	310.0248

Substituting for I_{sh} in equation (8),

$$I = I_{ph} - I_0 \left[\exp \left(\frac{V + IR_s}{a} \right) \right] - \left(\frac{V + IR_s}{R_p} \right) \quad (9)$$

The values of R_s and R_p (series and parallel resistance) can be calculated from eqn (9) using Newton-Raphson method. The iterative method to compute the pair (R_s , R_p) gave $R_s=0.45\Omega$, $R_p=310.0248\Omega$.^{[16],[17]}

I-V and P-V characteristics of solar array are obtained by varying the load resistance from zero to infinity. The characteristics are plotted for different irradiation and temperature conditions as shown in Fig.2 and Fig.3

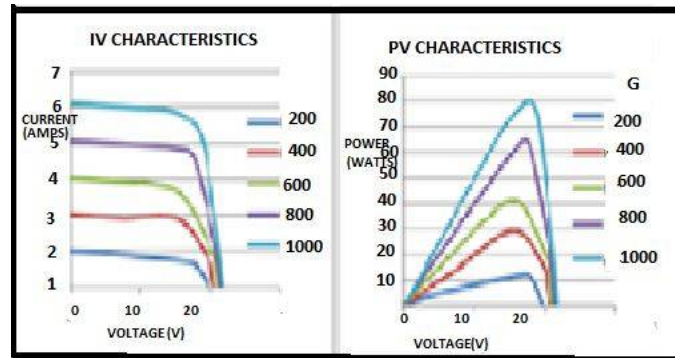

Fig.2 Solar array Characteristics with Varying Irradiation and Fixed Temperature T=298 K

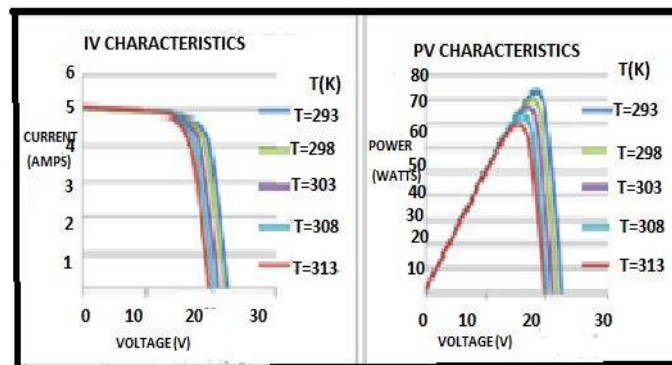

Fig.3 Solar array Characteristics with Varying Temperature and Fixed Irradiation G=1000 W/m²

From the Fig.2 and 3, it is inferred that increase in irradiation, increases the maximum power whereas the voltage at which maximum power is obtained remains constant. When temperature is increased, the maximum power decreases and the voltage corresponding maximum power also decrease.

B. DC-DC SEPIC Converter

The dc-dc converter is used to convert unregulated dc voltage to a constant or regulated voltage. All dc-dc converters operate by rapidly turning on and off a IGBT, a high frequency pulse. For the SEPIC, when the pulse is high/the IGBT is on, inductor1 is energised by the input voltage and inductor2 is energised by capacitor1. The diode is turn off and the output is maintained by capacitor. When the pulse is low/the IGBT is off, the inductors output through the diode to the load and the capacitors are charged. The greater percentage of time (duty cycle) the pulse is low, output will be high. This is because the longer the inductors energise, the output voltage is high. However, if the pulse lost too long, the capacitors will not be able to charge and the converter will fail.

$$V_o = \frac{V_s \cdot D}{1-D} \quad (10)$$

The output voltage is always greater than the input voltage and is related directly to the duty cycle. The reference voltage and the measured chopper voltage are compared and the error is given to the FUZZY LOGIC CONTROLLER.

International Journal of Innovative Research in Science, Engineering and Technology

(An ISO 3297: 2007 Certified Organization)

Website: www.ijirset.com

Vol. 6, Issue 8, August 2017

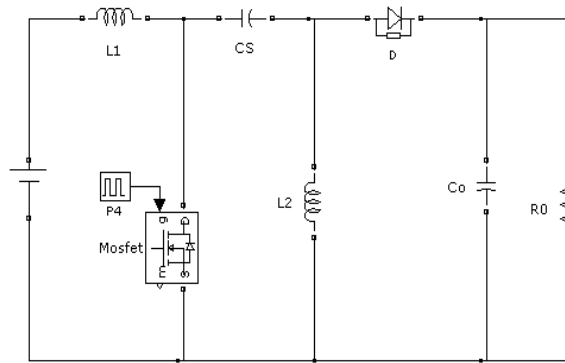

Fig.4 SEPIC Converter

The output of PI controller is modulated with a triangular carrier of frequency 10 kHz and is given as gate pulse to the chopper.

The selected parameters of chopper are tabulated in Table.2

Table.2 Selected parameters of chopper

S.No.	PARAMETER	VALUE
1	Input capacitor (C1)	100e-6
2	Input inductor (L)	5e-3
3	Output capacitor(C)	2200e-6
4	Switching frequency of switches	10 kHz

C. Maximum Power Point Tracking (MPPT)

This paper proposes the method to track power maximum power point by using fuzzy logic control [4],[5].Fuzzy Logic Controller is simulated using Fuzzy Toolbox in MATLAB. The inputs to the Fuzzy Logic Controller are voltage and current and the output is gate pulse of converter. Triangular Membership functions with uniform widths, Mamdani inference system and Centroid method of Defuzzification are used.

D. INVERTER

The main function of inverter in this system is to produce an ac output current equal to the reference current and in phase with it. The PV grid connected system provides a power conversion from the PV power to the line power. In addition to supplying real Power, Reactive Power is also supplied by the inverter. Based on the output of Hysteresis Current Controller the switches T_1 and T_4 are controlled for positive half cycle, and T_2 and T_3 are controlled for negative half cycle.

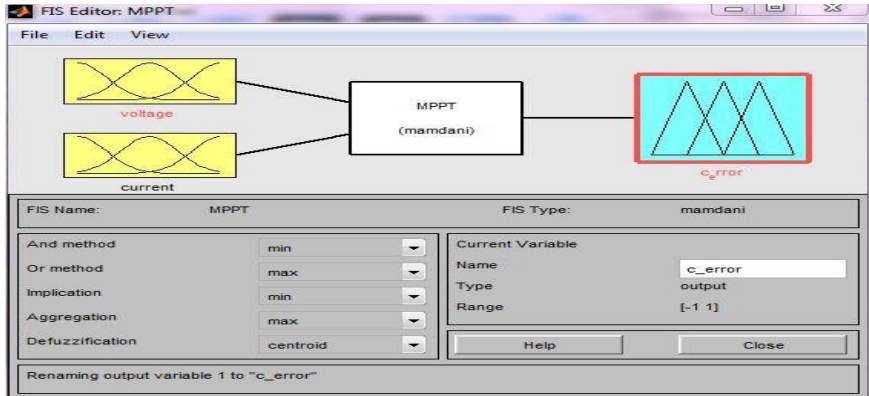

Fig.5 MPPT using FLC

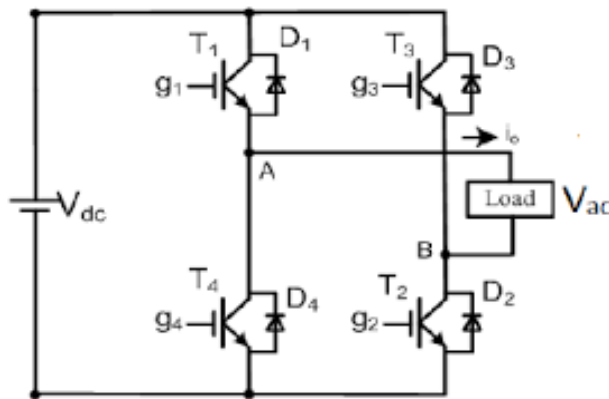

Fig.6 Inverter

E. MEMBERSHIP FUNCTIONS OF FLC:

Different membership functions are obtained for different inputs and outputs of fuzzy logic controller. Here, triangular memberships are considered.

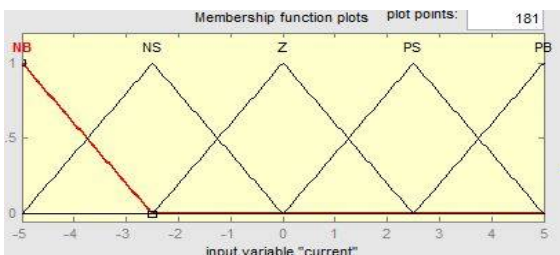

Fig.7 Membership function for voltage

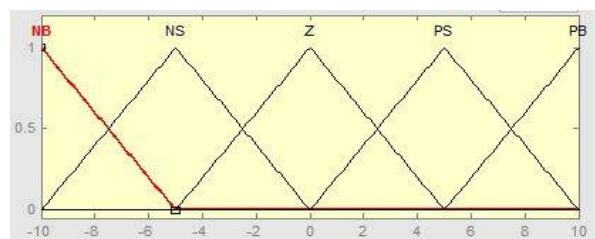

Fig.8 Membership function for current

International Journal of Innovative Research in Science, Engineering and Technology

(An ISO 3297: 2007 Certified Organization)

Website: www.ijirset.com

Vol. 6, Issue 8, August 2017

IV. SIMULATION RESULTS

To verify the feasibility of the proposed strategy, **simulations are carried out**. The figure 9 shows the Matlab Simulink diagram including solar sources with SEPIC converter and inverter.

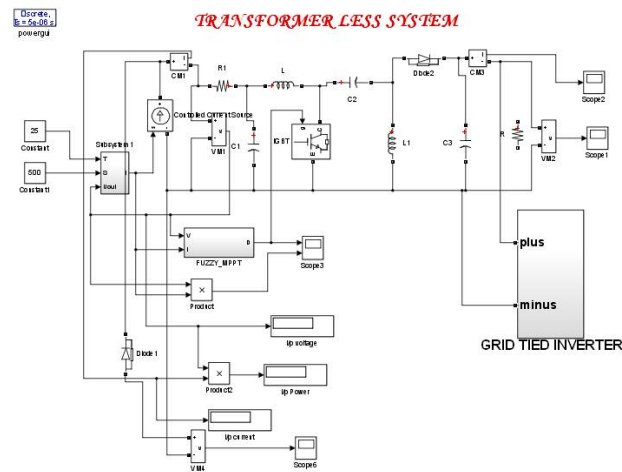

Fig.9. Proposed system Simulink diagram

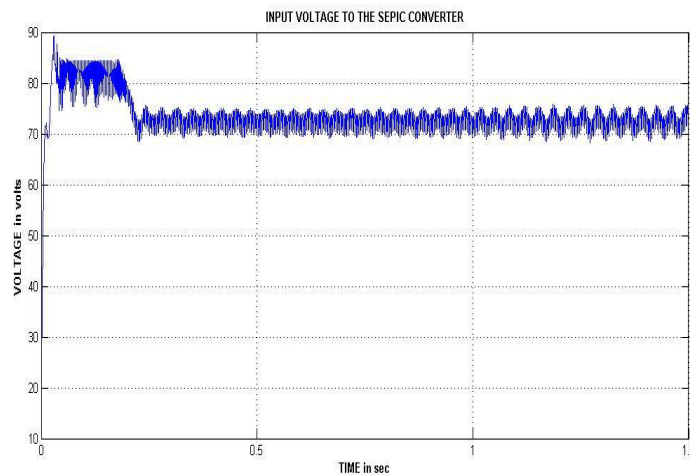

Fig.10 Input voltage to the SEPIC converter

From the solar cells the input voltage is 75V, it is given to the DC to DC converter.

International Journal of Innovative Research in Science, Engineering and Technology

(An ISO 3297: 2007 Certified Organization)

Website: www.ijirset.com

Vol. 6, Issue 8, August 2017

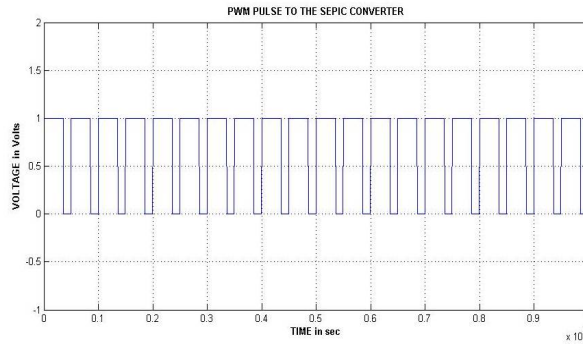

Fig.11 Gate pulse to SEPIC converter

The figure 11 shows the PWM pulse to the SEPIC converter with duty cycle 75%. The fuzzy logic algorithm maintains the width of the pulses.

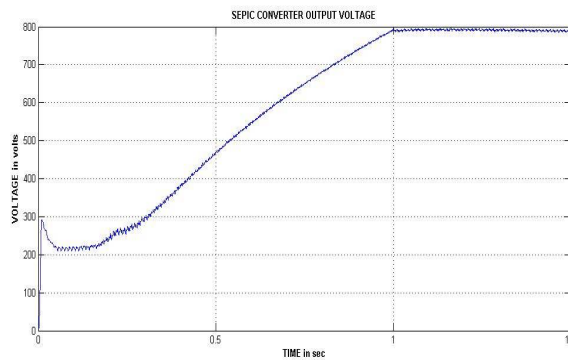

Fig.12. Output voltage of the SEPIC converter

The figure 12 shows the output voltage of the converter, with 75 volt input.

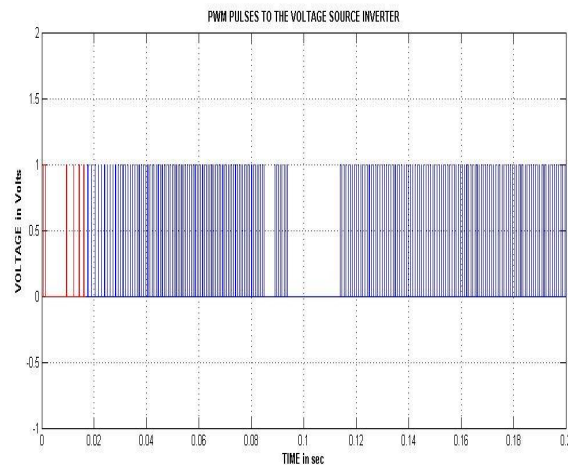

Fig.13. Gate pulse to VSI

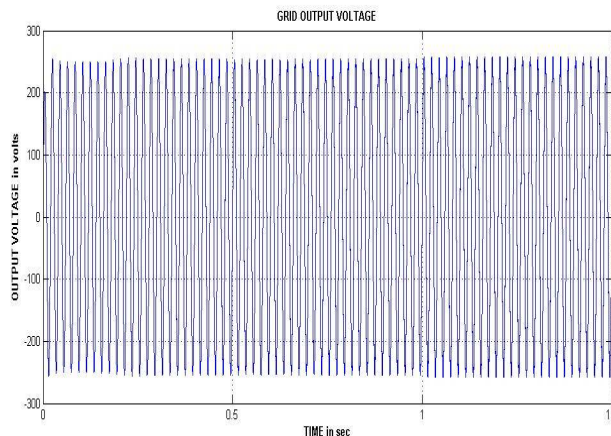

Fig.14 inverter output voltage

The figure 10 shows the grid output voltage from the voltage source inverter.

V. CONCLUSIONS

In this paper, renewable system based on solar cell energy system with SEPIC converter fed single phase three level inverter has been simulated. The generated voltages are filtered and boosted by Single Ended Primary Inductor converter. The SEPIC converter provides constant DC voltage to the single phase three level inverter. The fuzzy logic control based maximum power point tracking algorithm has been used to extract the maximum power from the hybrid energy system. The PI controller makes the inverter output voltage equal to the grid voltage. This system has lower operating cost and find applications in remote area power generation, constant speed and variable speed energy conversion systems and rural electrification. MATLAB/SIMULINK software is used to model the PV panel, DC-DC converters and the proposed hybrid system.

Future work:

This simulation work has to be implemented in hardware. Also the work has to be extended for reactive power compensation.

REFERENCES

- [1]J. Shoeman and J. van Wyk, "A simplified maximal power controller for terrestrial photovoltaic panel arrays," in Proc. IEEE PESC, 1982, pp. 361–367.
- [2]C. Sullivan and M. Powers, "A high-efficiency maximum power point tracker for photovoltaic arrays in a solar-powered race vehicle," in Proc. IEEE PESC, 1993, pp. 574–580.
- [3]C.-Y. Won, D.-H.Kim, S.-C.Kim, W.-S.Kim, and H.-S.Kim, "A new maximum power point tracker of photovoltaic arrays using fuzzy controller," in Proc. IEEE PESC'94, June 1994, pp. 396–403.
- [4]T.Hiyama, S. Kouzuma, and T. Imakubo, "Identification of optimal operating point of PV modules using neural network for real time maximum power tracking control," IEEE Trans. Energy Conversions., vol. 10, no. 2, pp. 360–367, Jun. 1995.
- [5]K. Hussein, I. Muta, T. Hoshino, and M. Osakada, "Maximum photovoltaic power tracking: An algorithm for rapidly changing atmosphere conditions," Proc. Inst. Electr. Eng., vol. 142, pt. G, no. 1, pp. 59–64, Jan. 1995.
- [6]J.Enslin,M.Wolf,D.Snyman,andW.Sweigers,"Integratedphotovoltaic maximum power point tracking converter," IEEE Trans. Ind. Electron., vol. 44, no. 6, pp. 769–773, Dec. 1997.
- [7] T. Hiyama and K. Kitabayashi, "Neural network based estimation of maximum power generation from PV module using environmental information," IEEE Trans. Energy Convers., vol. 12, no.3, pp. 241–247, Sep. 1997.
- [8]Weidong Xiaoand William G. Dunford, "A Modified Adaptive Hill Climbing MPPT Method for Photovoltaic Power Systems", 35thAnnual IEEE Power Electronics Specialists Conference, 2004, pp. 1957-1963.
- [9] Huajun Yu. , Junmin Pan., An Xiang, 2004."A multi-function grid-connected PV system with reactive power compensation for grid". Solar Energy 79 (2005) 101-106, Elsevier.

International Journal of Innovative Research in Science, Engineering and Technology

(An ISO 3297: 2007 Certified Organization)

Website: www.ijirset.com

Vol. 6, Issue 8, August 2017

- [10] Nicola Femia, Giovanni Petrone, Giovanni Spagnuolo and Massimo Vitelli, "Optimization of Perturb and Observe Maximum Power Point Tracking Method" IEEE Transactions on Power Electronics, Vol. 20, No. 4, July 2005, pp. 963-973.
- [11] Jung-Min Kwon, Kwang-Hee Nam, and Bong-Hwan Kwon, "Photovoltaic Power Conditioning System With Line Connection", IEEE Transactions On Industrial Electronics, Vol. 53, No. 4, August 2006.
- [12] Wu Libo, Zhao Zhengming, Liu Jianzheng "A Single-Stage Three-Phase Grid-Connected Photovoltaic System With Modified MPPT Method and Reactive Power Compensation" IEEE Transactions on energy conversion, vol. 22, no. 4, December 2007
- [13] Huan-Liang Tsai., Ci-Siang Tu., Yi-Jie Su., 2008 "Development of generalized photovoltaic model using MATLAB/Simulink ". Proceeding of the World Congress on Engineering and Computer Science October 22-24, San Francisco, USA.
- [14] Qiang Mei, Mingwei Shan, Liying Liu, Josep M. Guerrero. "A Novel Improved Variable Step -Size Incremental-Resistance MPPT Method for PV Systems" IEEE Transactions on industrial electronics, vol. 58, no. 6, June 2011.
- [15] Aissa Chouder, Santiago Silvestre, Nawel Sadaoui, Lazhar Rahmani, "Modelling and simulation of a grid connected PV system based on the evaluation of main PV module parameters", Elsevier Simulation Modelling Practice and Theory 20 (2012) Pp 46-58.
- [16] Amir Gheibi, S. Mohammad Ali Mohammadi, Malihe M. Farsangi, "Comparing performance of PID and fuzzy controllers in the presence of noise for a Photovoltaic System" Journal of mathematics and computer science (2014), 69-76
- [17] Faa-jeng Lin, Kuang-chin Lu, Ting-Han Ke, 2016, "Probabilistic wavelet fuzzy neural network based reactive power control for grid-connected three-phase PV system during grid faults". Renewable Energy 92 (2016) 437-449, Elsevier.