

Development of Predictive Current Control Technique Using ANFIS Controller for PMSM Motor Drive

T.Sravya¹, P.Munigowri²

P.G. Student, Department of Electrical & Electronics Engineering, Sri Padmavathi Mahila University, Tirupati, India¹

Assistant Professor, Department of Electrical & Electronics Engineering, Sri Padmavathi Mahila University,
Tirupati, India²

ABSTRACT: This paper proposes an effective Predictive current control(PCC) technique using ANFIS controller for fast torque monitoring and high performance of permanent magnet synchronous motor (PMSM) involving constant switching frequency. The conventional Proportional-Integral (PI) speed control has been widely used in industrial motor controls due to its capabilities in controlling linear plants. As, motor behaves as non-linear plant where the PI speed control may not be able to provide precise speed responses. With the fast growing of artificial intelligent in motor controls, the fuzzy logic and Adaptive Network Fuzzy Inference system (ANFIS) is available in more precise motor controls. In the proposed controlling technique, PCC is a combination of both dead beat and direct predictive control (DPC). In this paper PCC with ANFIS controller is developed in MATLAB SIMULINK and its results are compared with simulation results of PCC without ANFIS controller. The analysis illustrates the faster dynamic response and improved transient characteristics concerning speed changes as well as reduced current and torque ripples.

KEYWORDS: ANFIS controller, PCC, Permanent magnet synchronous motor, Dead beat and Direct Predictive control.

I. INTRODUCTION

The applications like robotics, machine tools and electric vehicle where high performance, high power density, fast torque and speed changes are required, PMSM motors are mostly used. More than 85% of drive systems use Induction machines at present but PMSM can replace them as they are more efficient which in turn can reduce the replacement cost. Field Oriented control (FOC) is the standard method of control for both PMSM and induction machine. In recent years new control strategies have been studied, among all those predictive current control technique is the most effective method for PMSM drive.

The principle of predictive control is to use the system model to predict the future behaviour of the state variable. Predictive control is mainly classified into four types [1], they are hysteresis based, trajectory based, dead beat control and model predictive control. Model predictive control (MPC) is again classified into finest set MPC also known as DPC and continuous set MPC. PCC is combination of dead beat algorithm and DPC. The advantages from both dead beat and DPC are taken to design a new control technique PCC.

In dead beat, PMSM model is used to predict the stator voltages after one modulation period allowing converging on desired current [2]. PWM process drives the converter ensuring constant switching frequency, which is main characteristic of dead beat algorithm. This dead beat control is sensitive to parameter mismatching error. System delay and inverter non linearity [3]. This control does not demand cost function minimization, so it is computationally less complex compared to DPC.

International Journal of Innovative Research in Science, Engineering and Technology

(A High Impact Factor & UGC Approved Journal)

Website: www.ijirset.com

Vol. 6, Issue 8, August 2017

DPC can handle system constraints like maximum output voltage limits from inverter and maximum motor current. The most complex part of DPC is cost function minimization. Based on the application DPC can be designed with fully different goals like minimizing power losses, switching frequency or common mode voltage, by adjusting weighting factors introduced in each term utilizing just a single control law [4]. The main drawback of DPC is switching frequency may vary which will lead to switching losses and which may also requires an EMI filter design.

PCC is a convenient combination of both dead beat and DPC. It is based on the optimization of an objective function and the output of the controller is the reference voltage in the d-q frame and like set of pulses in DPC. In PCC this reference voltage is given to pulse modulator as in dead beat scheme. Cost function chosen contains terms related to current control square error. This PCC technique offers fast dynamic response and reduced torque and current ripples.

The paper is described in six sections in the present section control technique is explained with respect to other methods encountered in literature. In section II PMSM dynamic model equations are presented. In section III control scheme PCC for a PMSM drive is explained. In section IV the proposed control scheme PCC with ANFIS controller is explained. In section V simulation results both the schemes are compared. Finally in section VI summary and conclusions of present work are given.

I. DYNAMIC MODEL OF PMSM

With respect to d-q reference frame rotating synchronously with rotor the electrical subsystem of PMSM can be modelled and written in matrix form as

$$\frac{d}{dt} \begin{bmatrix} i_d(t) \\ i_q(t) \end{bmatrix} = \begin{bmatrix} -\frac{R}{L_d} & \frac{\omega_e(t)L_q}{L_d} \\ \frac{\omega_e(t)L_d}{L_q} & -\frac{R}{L_q} \end{bmatrix} \begin{bmatrix} i_d(t) \\ i_q(t) \end{bmatrix} + \begin{bmatrix} \frac{1}{L_d} & 0 \\ 0 & \frac{1}{L_q} \end{bmatrix} \begin{bmatrix} V_d(t) \\ V_q(t) \end{bmatrix} - \begin{bmatrix} 0 \\ \frac{\omega_e(t)\Delta_d}{L_q} \end{bmatrix} \quad (1)$$

The d-q axes current components $i_q(t), i_d(t)$ are used as state variables in the dynamic model of PMSM. The d-q axes voltages $V_d(t), V_q(t)$ are taken as inputs of the system. The above state space model is treated as second order LPV model. The third term in the equation which is proportional to the product of the electrical frequency and permanent rotor magnetic flux is non controllable input. The electromagnetic torque of motor is given by

$$T_e(t) = \frac{3P}{2} [\Delta_d i_q(t) - \Delta_d i_d(t)] \quad (2)$$

From (2) we can say that if d-axis current is set to zero, the rate N_m to ampere ratio is maximized so that the excitation of the machine is achieved by the magnetic material of the rotor. The relation between electromagnetic torque, mechanical load torque and the rotational speed is give as

$$J \frac{d\omega}{dt} = T_e(t) - T_m - F\omega(t) \quad (3)$$

International Journal of Innovative Research in Science, Engineering and Technology

(A High Impact Factor & UGC Approved Journal)

Website: www.ijirset.com

Vol. 6, Issue 8, August 2017

II. PCC SCHEME FOR PMSM

In order to optimize the performance, PCC replaces the linear PI controllers used in classical FOC scheme using PC technique.

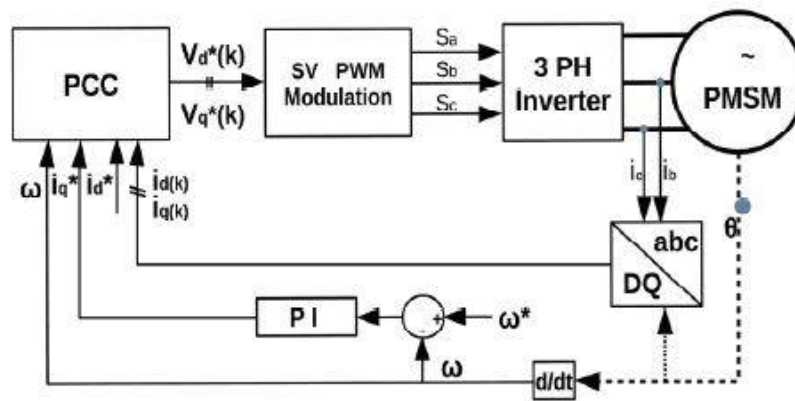

Fig.1 main scheme of PCC, using PI control for speed control loop

Similar to other predictive controllers, deadbeat algorithm is based on the motor model in order to obtain the voltage reference that should be applied in order to obtain the desired current at the end of the switching period, i_{dqk+1} . The desired current is indicated by the reference i_{dqk}^* . Rotational speed, ω , and d-q current measurements, i_{dqk} are derived from the rotor angle acquired by the encoder and the phase current measurements respectively, at every sampling period. Some delay can be introduced in the system due to the computation time, sensors and actuation propagation time. That is why delay compensation is introduced in dead beat schemes.

To implement PCC for each time step differential equation model of PSM should be transformed into discrete model. After that cost function has to be defined. Control variables at each step should be controlled, in order to minimize the cost function satisfying all the constraints.

Discretization of the machine model: By using discrete model, the next step time state of the d-q currents could be predicted, by the present value of the d-q currents, the measured electrical speed and the input d-q voltages. The PMSM can be modeled in discrete time by means of Taylor series expansion if sampling period T_s is taken short enough. State space model (1) is transformed to discrete state space equation as:

$$\begin{bmatrix} i_{dk+1} \\ i_{qk+1} \end{bmatrix} = \begin{bmatrix} 1 - \frac{RT_s}{L_{dq}} & \omega_{ek} T_s \\ -\omega_{ek} T_s & 1 - \frac{RT_s}{L_{dq}} \end{bmatrix} \begin{bmatrix} i_{dk} \\ i_{qk} \end{bmatrix} + \begin{bmatrix} \frac{T_s}{L_{dq}} & 0 \\ 0 & \frac{T_s}{L_{dq}} \end{bmatrix} \begin{bmatrix} V_{dk} \\ V_{qk} \end{bmatrix} - \begin{bmatrix} 0 \\ \frac{\omega_{ek} T_s \Delta_d}{L_{dq}} \end{bmatrix} \quad (4)$$

Where $L_{dq} = L_d = L_q$, is the stator inductance, which takes the same value along both axes, as the machine is symmetrical. The described discretization method, assumes that the rotational speed is constant during a sampling period, based on the fact that the mechanical time constant is much greater than the electrical one.

Predictive optimization method: On the next step, the problem of the controller design involves the computation of the reference voltage that should be implemented at the present time step, ensuring that the current will follow the reference at the next step. This goal can be expressed as the minimization of the predicted currents, i_{dk+1} divergence from the i_{dk}^* reference value. A cost function that incorporates this objective is formulated as follows:

International Journal of Innovative Research in Science, Engineering and Technology

(A High Impact Factor & UGC Approved Journal)

Website: www.ijirset.com

Vol. 6, Issue 8, August 2017

$$\hat{g}(V_{d_k}^*, V_{q_k}^*) = i_{d_{k+1}}^2 + (i_{q_{k+1}} - i_{q_k}^*)^2 \quad (5)$$

The cost function (5) contains the Voltages $V_{d_k}^*$, $V_{q_k}^*$ as variables that have to be determined at each time step ensuring that the function takes its minimum value. The prediction currents $i_{d_{k+1}}$, $i_{q_{k+1}}$ can be expressed as function of the reference voltages and the measured current and speed values i_{d_k} , i_{q_k} and ω_k respectively through (4). Finally, the cost function can take the following form:

$$\hat{g}(\underline{u}_k) = \underline{u}_k^T \lambda^2 \underline{u}_k + \mu_k \underline{u}_k \quad (6)$$

The parameters of this cost function are determined as follows:

$$\underline{u}_k = \begin{bmatrix} V_{d_k} \\ V_{q_k} \end{bmatrix}, \quad \lambda = \frac{T_s}{L_{dq}}$$

$$\mu_k = [\mu_{1_k} \quad \mu_{2_k}]$$

$$\mu_{1_k} = 2\lambda(a_1 i_{d_k} + a_2 i_{q_k})$$

$$\mu_{2_k} = 2\lambda(-a_2 i_{d_k} + a_1 i_{q_k} - i_{q_k}^* - \omega_{ek} \lambda \Delta_d)$$

$$a_1 = \frac{RT_s}{L_{dq}}, \quad a_2 = \omega T_s$$

A constraint imposed on the problem is that the current amplitude never exceeds a defined maximum value, for motor safety and reliability reasons. The maximum current is selected by the technical specifications of the motor as the maximum transient permissible current [8]. Finally the equations used for the design of PCC block are

$$V_{d_k}^* = \frac{1}{\lambda} (i_d^* - a_1 i_{d_k} - a_2 i_{q_k}) \quad (7)$$

$$V_{q_k}^* = \frac{1}{\lambda} (i_q^* + a_2 i_{d_k} - a_1 i_{q_k}) + \omega \Delta_d \quad (8)$$

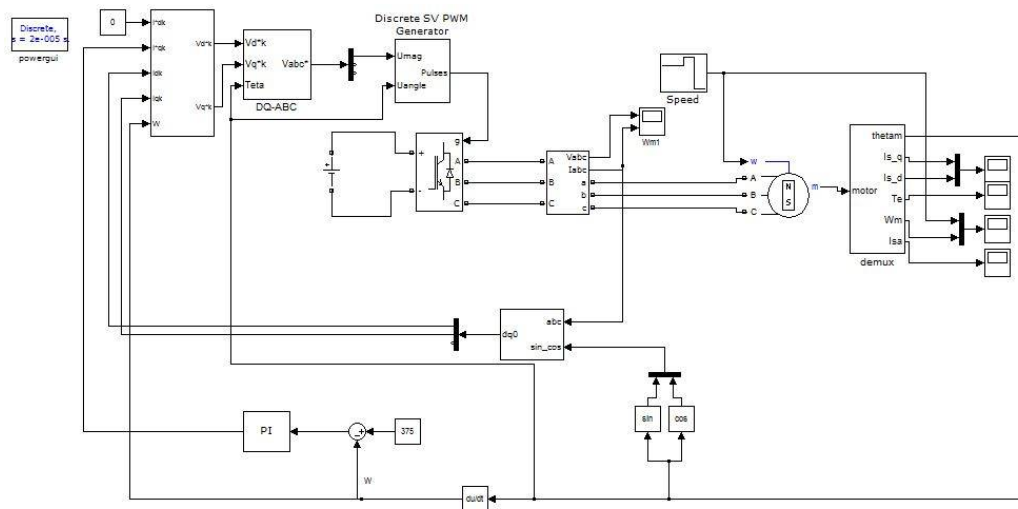

Fig.2 Simulink Model of PCC

III. THE PROPOSED CONTROL SCHEME PCC WITH ANFIS CONTROLLER

In this proposed scheme PI controller in the speed loop is replaced with the ANFI controller. ANFIS uses the neural network’s ability to classify data and find patterns. It then develops a fuzzy expert system that is more transparent to the user and also less likely to produce memorization error than a neural network. ANFIS keeps the advantages of a fuzzy expert system, while removing (or at least reducing) the need for an expert. The problem with ANFIS design is that large amounts of training data require developing an accurate system. The objective of ANFIS is to adjust the parameters of a fuzzy system by applying a learning procedure using input–output training data. Basic architecture of ANFIS that has two inputs x and y and one output f . This allows the rule base to adapt

As a simple example, a fuzzy inference system with two inputs x and y and one output z is assumed. The first-order Sugeno fuzzy model, a typical rule set with two fuzzy If–Then rules can be expressed as

Rule 1: If x is A_1 and y is B_1 , then $f_1 = p_1x + q_1y + r_1$

Rule 2: If x is A_2 and y is B_2 , then $f_2 = p_2x + q_2y + r_2$

The resulting Sugeno fuzzy reasoning system is shown here, the output z is the weighted average of the individual rules outputs and is itself a crisp value.

SIMULINK MODEL

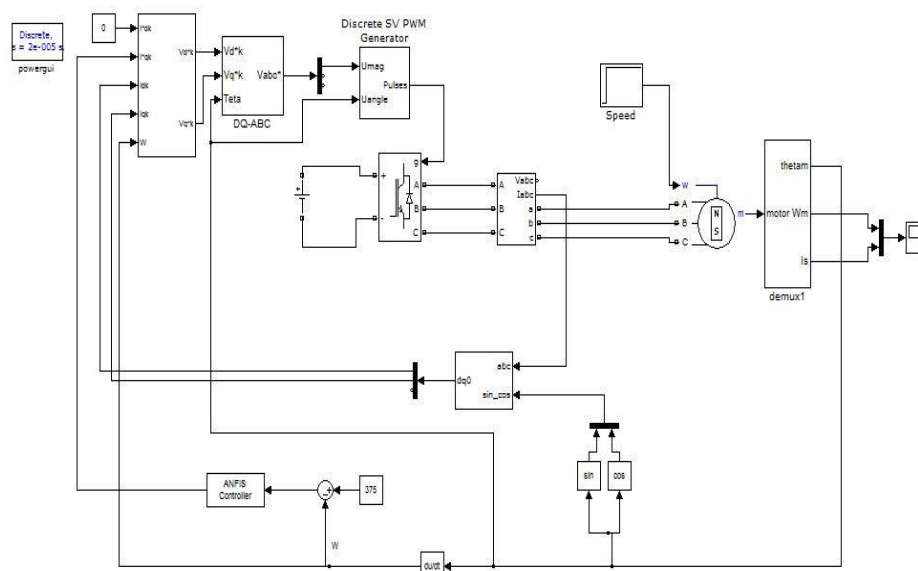

Fig.3 Simulink Model of PCC with ANFIS controller

International Journal of Innovative Research in Science, Engineering and Technology

(A High Impact Factor & UGC Approved Journal)

Website: www.ijirset.com

Vol. 6, Issue 8, August 2017

V.COMPARISION OF SIMULATION RESULTS

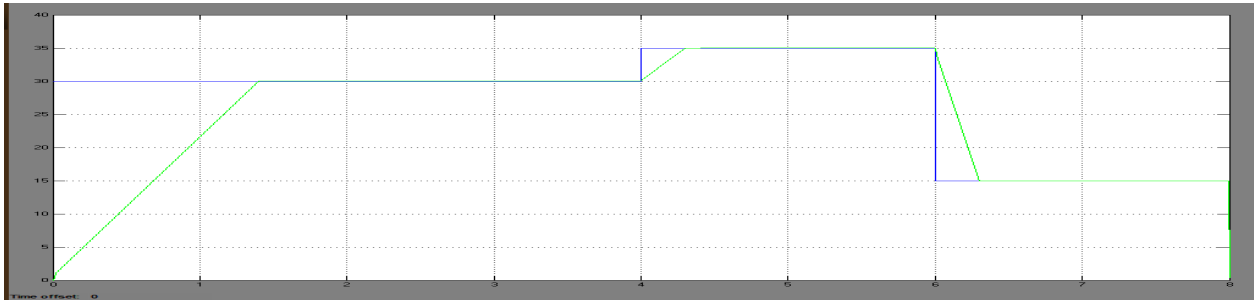

Fig.4 Rotational speed response –PI-PCC

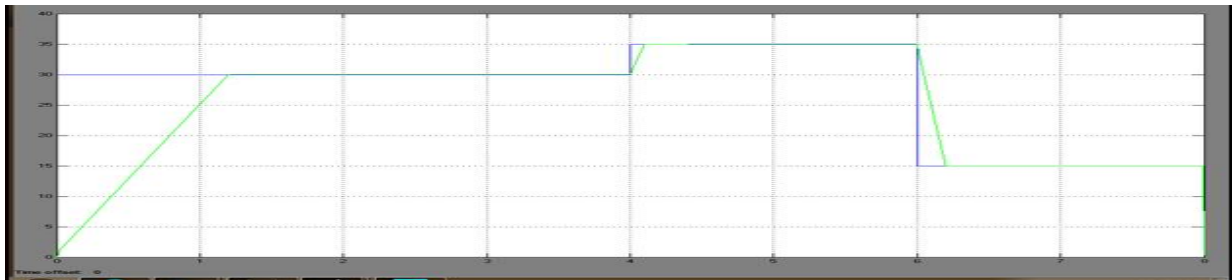

Fig.5 Rotational speed response ANFIS-PCC

In fig.4 & fig.5, PI-PCC, and ANFIS-PCC simulation results were compared, concerning the system response under sudden load torque change and reference speed increment or decrement. It should be mentioned that in these simulations, maximum transient motor current was considered for reliability and safety reasons. It is clear from these two figures that ANFIS-PCC produces fast dynamic response compared to PI-PCC.

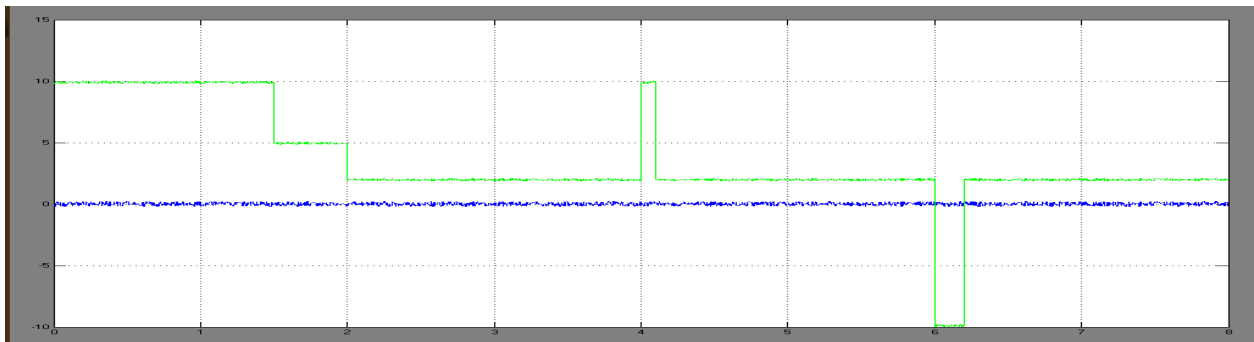

Fig.6 D-Q Current response - PI-PCC

International Journal of Innovative Research in Science, Engineering and Technology

(A High Impact Factor & UGC Approved Journal)

Website: www.ijirset.com

Vol. 6, Issue 8, August 2017

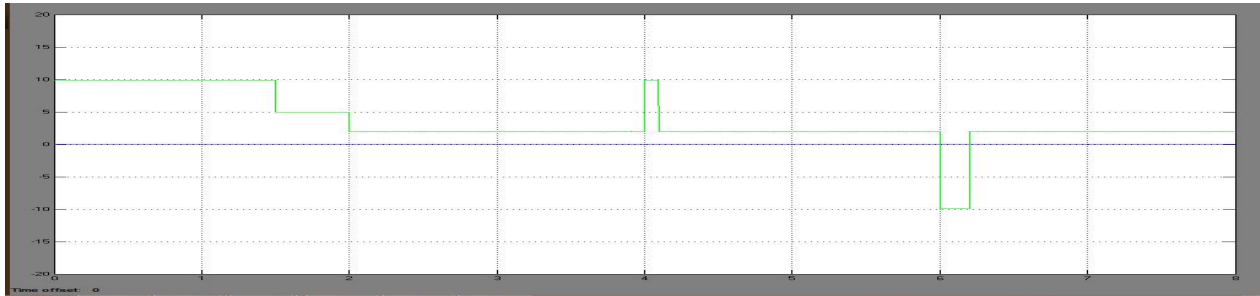

Fig.7 D-Q Current response -ANFIS-PCC

Fig.6 & Fig.7 shows the D-Q current responses for two types of control techniques. From these two figures we can observe that ripple content in the d-q currents is less in ANFIS-PCC when compared to PI-PCC. Due to the decrease in ripple content THD will be decreased.

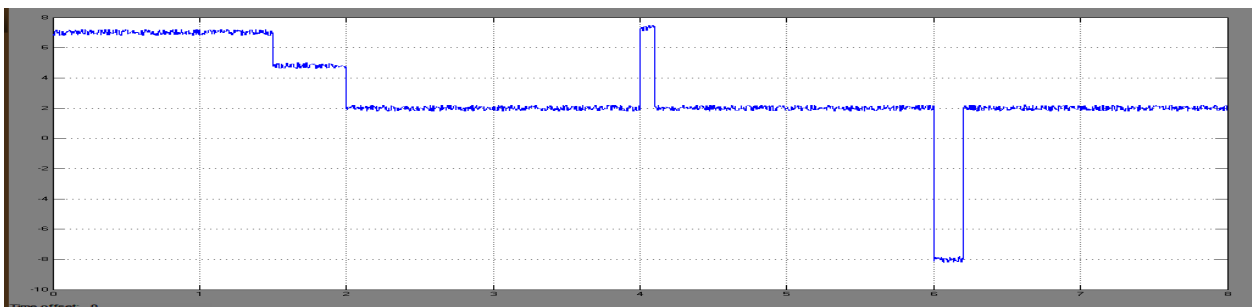

Fig.8 Electromagnetic Torque response -PI-PCC

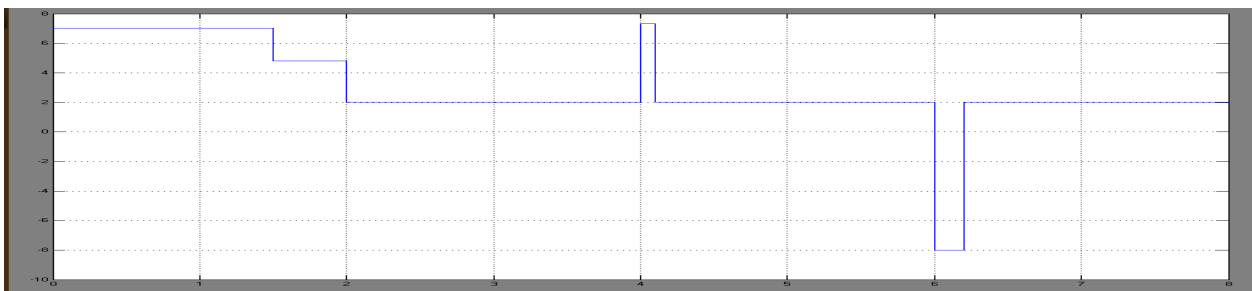

Fig.9 Electromagnetic Torque response -ANFIS-PCC

Fig.8 & Fig. 9 shows electromagnetic torque response by using both the techniques. From these figures we can observe that ripple content in the torque response of ANFIS-PCC is less than that of PI-PCC. From Figs.6, 7, 8 and 9 it is clear that torque and current involve similar changes during transients, as electromagnetic torque is directly proportional to i_q current component.

These results illustrates that ANFIS-PCC can efficiently handle changes to external inputs such as the mechanical load torque. Consequently, ANFIS-PCC prevents system from overshooting and gives faster speed response.

International Journal of Innovative Research in Science, Engineering and Technology

(A High Impact Factor & UGC Approved Journal)

Website: www.ijirset.com

Vol. 6, Issue 8, August 2017

VI. CONCLUSION

In this paper, a constant switching frequency PCC based on a convenient combination of deadbeat and DPC techniques has been developed for a PMSM drive system, designed for electric vehicle applications. The proposed method is analyzed using MATLAB/SIMULINK software. From the above comparison of simulation results it is clear that ANFIS controller gives fast speed response than PI controller. ANFIS controller has significantly reduced the overshoot as well as the settling time in comparison to rest of controllers. It also cancelled the disturbance effects such as speed and torque change and maintained steady-state accuracy. Adaptive neuro fuzzy inference system has smaller overshoot and less rising and settling time than conventional PI controller and has better dynamic response properties and steady state properties.

REFERENCES

- [1] Member, IEEE, Marian P. Kazmierkowski, Fellow, IEEE, Ralph M. Kennel, Senior Member, IEEE, Daniel E. Quevedo, Member, IEEE, and José Rodríguez, Senior Member, IEEE. "Predictive Control in Power Electronics and Drives" Patricio Cortés, *IEEE Trans. Power Electron.*, vol. 55, no. 12, pp. 612–618, Mar. 2008
- [2] Alexandros D. Alexandrou, Nikolaos K. Adamopoulos, and Antonios G. Kladas, Senior Member, IEEE. "Development of a Constant Switching Frequency Deadbeat Predictive Control Technique for Field oriented PMSM Drive" *IEEE Trans. Power Electron.*, 2016.
- [3] Abbaszadeh, A. M. Miremadi, D. A. Khaburi and M. Esmaili, "Permanent synchronous motor predictive deadbeat current control robustness investigation", in *2015 IEEE 6th Power Electronics, Drives Systems and Technologies Conference*, DOI:10.1109/PEDSTC.2015.7093309, 2015, pp. 406-411.
- [4] P. Cortes, S. Kouro, B. La Rocca, R. Vargas, J. Rodriguez, J. I. Leon, S. Vazquez and L. G. Franquelo, "Guidelines for weighting factors design in Model Predictive Control of power converters and drives", in *2009 IEEE International Conference on Industrial Technology*, DOI:10.1109/ICIT.2009.4939742, 2009, pp. 1-7.
- [5] Jain, S.K., Das, D. & Srivastava, D.K., "Application of ANN for reservoir inflow prediction and operation" *J. Water Resour. Plan. Manage. ASCE* 125(5), 263-271, 1999.
- [6] B. K. Bose, *Modern Power Electronics and A.C. Drives*. Prentice Hall PTR, 2002.
- [7] R. M. Kennel, M. P. Kazmierkowski, R. M. Kennel, D.E. Quevedo and J. Rodriguez, "Predictive control in power electronics and drives.", *IEEE Trans. Ind. Electron.*, vol. 55, DOI: 10.1109/TIE.2008.2007480, no. 12, pp. 4312-4324, Dec. 2008.
- [8] Shun-Chung Wang and Yi-Hwa Liu.: "A Modified PI-Like Fuzzy Logic Controller for Switched Reluctance Motor Drives" *IEEE Transactions on Industrial Electronics*, vol. 58, no. 5, May 2011.
- [9] F. Morel, X. Lin-Shi, J. M. Retif, B. Allard and C. Buttay, "A Comparative Study of Predictive Current Control schemes for a Permanent-Magnet Synchronous Machine Drive", *IEEE Trans. Ind. Electron.*, vol. 56, DOI:10.1109/TIE.2009.2018429, no. 7, pp. 2715-2728, Jul. 2009.
- [10] E. Fuentes, D. Kalise, J. Rodriguez, R.M Kennel, "Cascade-Free Predictive Speed Control for Electrical Drives", *IEEE Trans. Ind. Electron.*, vol. 61, no. 5, DOI: 10.1109/TIE.2013.2272280, pp. 2176-2184, 2014.