

International Journal of Innovative Research in Science, Engineering and Technology

(A High Impact Factor & UGC Approved Journal)

Website: www.ijirset.com

Vol. 6, Issue 8, August 2017

VLSI Design and Implementation of a Novel Low Latency Parallel Adder

Tappa Prashanth¹, Dr.S.P.V.Subba Rao²

PG Scholar, Dept of ECE, Sreenidhi Institute of Science and Technology, Hyderabad, Telangana, India¹

Professor & HOD, Dept of ECE, Sreenidhi Institute of Science and Technology, Hyderabad, Telangana, India²

ABSTRACT: Many pipelined adaptive signal processing systems are subject to a trade-off between throughput and signal processing performance incurred by the pipelined adaptation feedback loops. In the conventional synchronous design regime, such throughput/performance trade-off is typically fixed since the pipeline depth is usually determined in the design phase and remains unchanged in the run time. Nevertheless, in many real-life scenarios, the overall system performance can be potentially improved if we can run-time dynamically configure this trade-off. With this motivation, we propose to apply self-timed pipeline, an alternative to synchronous pipeline, to implement the pipelined adaptive signal processing systems, in which the pipeline depth can be dynamically changed to realize run-time configurable throughput/performance trade-offs. Based on a well-known high speed self-timed pipeline style, we developed architecture and circuit level design techniques to implement the self-timed pipelined adaptation feedback loop with configurable pipeline depth.

We demonstrate the proposed design approach using a delayed least mean square (DLMS) adaptive equalizer for magnetic recording read channel. The data transfer rate in hard disk varies as the read head moves among tracks with different distance from the center of the disk platter. By adjusting the pipeline depth on-the-fly, the DLMS equalizer can dynamically track the best equalization performance allowed by the varying data transfer rates. Simulation result shows a significant performance improvement compared with its synchronous counterpart.

KEYWORDS: Manchester coding, Encoder, Decoder, NRZ, Moore's law, UART, clock frequency

I. INTRODUCTION

Over the last two decades, adaptive signal processing has developed into a self-contained field [1], [2] that finds wide range of real-life applications such as adaptive equalization, noise and echo cancellation, linear predictive coding, and adaptive beam-forming. Adaptive signal processing algorithms are characterized by their recursive operations for realizing algorithmic self-designing/adaptation. To realize high-throughput VLSI implementation of adaptive signal processing algorithms, architecture-level technique pipelining is typically used [3]. Pipelined adaptive signal processing systems are essentially subject to a trade-off between system throughput and signal processing performance, i.e., deeper pipelined adaptation feedback loop can realize higher throughput, but the delayed feedback will incur larger performance degradation. It should be pointed out that, for other recursive algorithms such as infinite impulse response (IIR) filtering and Viterbi algorithm, direct pipelining may simply ruin their functionality and appropriate algorithm-level modification is required for the use of pipelining. A pipelined adaptive signal processing algorithm implemented using the conventional synchronous pipeline typically has a fixed pipeline depth that is determined in the design phase to accommodate the highest run-time throughput requirement. Although it is possible to on-the-fly configure the pipeline depth of synchronous pipeline by selectively bypassing certain levels of registers, this is very inflexible and cannot realize fine-grain graceful configuration on the throughput/performance trade-offs. For example, consider an 8-stage pipelined recursive adaptation loop in which the registers are almost evenly placed along the loop for maximizing the throughput. If we bypass one level of registers to realize a 7-stage pipeline, the delay of the critical path may double and the throughput will reduce almost by half.

International Journal of Innovative Research in Science, Engineering and Technology

(A High Impact Factor & UGC Approved Journal)

Website: www.ijirset.com

Vol. 6, Issue 8, August 2017

Self-timed pipeline [4], [5] works in a different way from its synchronous counterpart. Without a common and discrete notion of time, self-timed pipeline relies on the handshake between components to perform the synchronization and communication. Each distinct data propagating through a self-timed pipeline is conventionally called a token. The pipeline depth of a self-timed pipeline simply equals the number of tokens present in the pipeline at the same time. Hence, we can dynamically configure the pipeline depth by controlling the number of tokens present in the pipeline. This property of self-timed pipeline has been exploited in the design of a mixed synchronous-asynchronous FIR filter that can support variable latency (in terms of clock cycles) [6] and power management of an embedded, single-issue processor [7]. In pipelined adaptive signal processing systems, the pipeline depth of the adaptation feedback loops is the key to tune the inherent tradeoff between throughput and signal processing performance. This directly motivates us to apply self-timed pipeline for the implementation of adaptive signal processing systems to realize gracefully configurable throughput/performance tradeoff. This can be leveraged to improve the overall system performance in many circumstances. For example, for adaptive signal processing systems with variable data rate, we can dynamically adjust the pipeline depth to the minimum allowable value according to the current data rate to realize the best signal processing performance. Although the basic idea of the above design approach is simple and intuitive, how to implement it in the real systems involves the following three critical design issues:

- 1) What type of self-timed pipeline structure should be used? Clearly, to justify the practicality of this design approach, the employed self-timed pipeline must be able to support the same (or comparable) throughput as its synchronous counterpart when they have the same pipeline depth. This means that the recursive self-timed pipeline datapath should have the same (or comparable) propagation delay as its synchronous counterpart. This is a very strict requirement since most self-timed pipeline design schemes involve extra delay overhead for realizing self-timed handshake and have the longer latency than their synchronous counterparts, although they can support very fine-grain pipeline to realize high throughput. In this work, we propose to use the well-known Ted William's high-speed self-timed pipeline [4], [8] because of its zero-delay-overhead feature (i.e., no extra handshake delay is incurred when data propagate through the pipeline). Hence the zero-delay-overhead pipeline can achieve the same latency performance as its synchronous counterpart.
- 2) How to realize the self-timed data flow synchronization in the recursive adaptation loop? In self-timed data path, synchronization of parallel computational threads relies on forks and joins, where fork refers to a stage with one input channel and multiple output channels and join refers to a stage with multiple input channels and a single output channel. The recursive adaptation loop of adaptive signal processing algorithms contains many forks and joins. However, like many other self-timed pipeline styles, the zero-delay-overhead self-timed pipeline was initially proposed for linear datapath (i.e., without forks and joins). Therefore, it must be appropriately modified to support forks and joins.
- 3) How to realize run-time addition/removal of tokens in order to change the pipeline depth? In a feed forward only datapath, the pipeline depth can be readily changed by adjusting the input data rate. However, as we will show later, it is not trivial to change the pipeline depth in recursive adaptation loops. We have to design some special circuit elements that can be placed on the recursive adaptation loop to realize run-time addition/removal of tokens.

II. BACKGROUND

This section briefly describes the zero-delay-overhead self-timed pipeline according to [4] and discusses some basic concepts and properties of self-timed pipeline. For detailed discussion on self-timed design, readers are referred to [5]. Fig. 1(a) shows the structure of a zero-delay-overhead self-timed pipeline, where the function block at each pipeline stage is implemented using dynamic differential cascode voltage switch logic (DCVSL) [12] as illustrated in Fig. 1(b).

International Journal of Innovative Research in Science, Engineering and Technology

(A High Impact Factor & UGC Approved Journal)

Website: www.ijirset.com

Vol. 6, Issue 8, August 2017

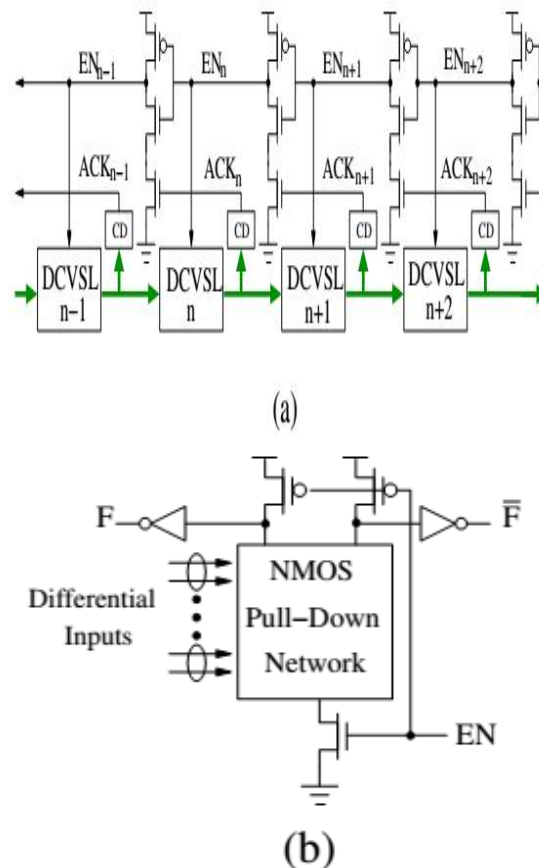

Fig. 1. (a) Zero-delay-overhead self-timed pipeline structure, and (b) DCVSL structure.

The data validity information in support of self-timed operation is embedded into the dual-rail signaling of the DCVSL logic: When the dual-rail output F and \bar{F} are both 0, it represents an invalid datum; when one of F and \bar{F} switches to 1 during evaluation ($EN=1$), it represents a valid datum (1 or 0). The completion detector (CD) at each stage, as shown in Fig. 1(a), generates 1 when it detects valid data, otherwise generates 0. The basic idea of zero-delay-overhead self-timed pipeline is to make each DCVSL stage keep ready-to-evaluate status so that it can start the evaluation as soon as tokens arrive, hence tokens can propagate through the pipeline without being blocked (or delayed) by handshake. According to the pipeline as shown in Fig. 1(a), the operation of zero-delay-overhead self-timed pipeline can be described as follows: The pipeline is initialized in such a way that each stage generates invalid output data (i.e., each ACK_i is 0) and is ready to evaluate (i.e., each EN_i is 1). Once valid data enter the pipeline and reach stage n , stage n starts the evaluation; after finishing the evaluation, it outputs valid data to its successor (i.e., stage $n + 1$) that will subsequently start the evaluation. The output valid data of stage n will invoke ACK_n switch from 0 to 1. As both EN_n and ACK_n are 1, according to Fig. 1(a), EN_{n-1} will switch from 1 to 0, leading to the precharge of stage $n - 1$. In the same manner, after the stage $n + 1$ finishes the evaluation and generates valid data, stage $n + 2$ will start to evaluate and stage n will be precharged (i.e., EN_n switches from 1 to 0). Clearly, $EN_n=0$ will make EN_{n-1} switch back to 1 so that stage $n - 1$ becomes ready to receive and evaluate new valid data. In this way, valid data can propagate through the pipeline datapath. The name zero-delayoverhead comes from the fact that the forward propagation latency exactly equals the function block latency without any extra delay incurred by self-timed handshake as in many other self-timed pipeline design styles. Such high speed performance comes at the cost of degraded robustness, i.e., to guarantee the correct functionality, the precharge of a stage must be faster than the evaluation of its successor. This assumption is practically reasonable and can be easily satisfied in the real implementations. Finally, we note that the dual-rail

International Journal of Innovative Research in Science, Engineering and Technology

(A High Impact Factor & UGC Approved Journal)

Website: www.ijirset.com

Vol. 6, Issue 8, August 2017

dynamic logic DCVSL is self-consistent with such zero-delay-overhead self-timed handshake and can provide a 2x speed performance advantage compared with conventional static CMOS logic. As the cost, dynamic circuits generally suffer from higher power dissipation and less noise immunity.

III. DESIGN OF PASTA

In this section, the architecture and theory behind PASTA is presented. The adder first accepts two input operands to perform half additions for each bit. Subsequently, it iterates using earlier generated carry and sums to perform half-additions repeatedly until all carry bits are consumed and settled at zero level.

A. Architecture of PASTA

The general architecture of the adder is shown in Fig. 1. The selection input for two-input multiplexers corresponds to the Req handshake signal and will be a single 0 to 1 transition denoted by SEL. It will initially select the actual operands during SEL=0 and will switch to feedback/carry paths for subsequent iterations using SEL=1. The feedback path from the HAs enables the multiple iterations to continue until the completion when all carry signals will assume zero values

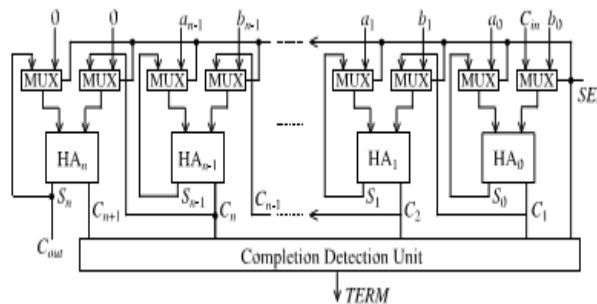

Fig. 2 General block diagram of PASTA

B. State Diagrams

In Fig. 3, two state diagrams are drawn for the initial phase and the iterative phase of the proposed architecture. Each state is represented by $(C_{i+1}S_i)$ pair where C_{i+1} , S_i represent carry out and sum values, respectively, from the i th bit adder block. During the initial phase, the circuit merely works as a combinational HA operating in fundamental mode. It is apparent that due to the use of HAs instead of FAs, state (11) cannot appear.

During the iterative phase (SEL=1), the feedback path through multiplexer block is activated. The carry transitions (C_i) are allowed as many times as needed to complete the recursion. From the definition of fundamental mode circuits, the present design cannot be considered as a fundamental mode circuit as the input-outputs will go through several transitions before producing the final output. It is not a Muller circuit working outside the fundamental mode either as internally; several transitions will take place, as shown in the state diagram. This is analogous to cyclic sequential circuits where gate delays are utilized to separate individual states.

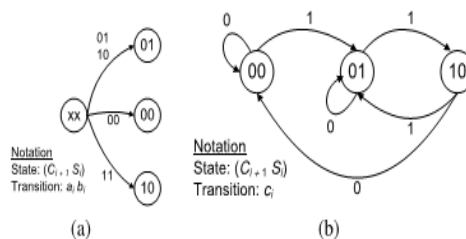

Fig. 3 State diagrams for PASTA. (a) Initial phase. (b) Iterative phase

International Journal of Innovative Research in Science, Engineering and Technology

(A High Impact Factor & UGC Approved Journal)

Website: www.ijirset.com

Vol. 6, Issue 8, August 2017

C. Recursive Formula for Binary Addition

Let S_i^j and C_{i+1}^j denote the sum and carry, respectively, for i th bit at the j th iteration. The initial condition ($j=0$) for addition is formulated as follows

$$S_i^0 = a_i \oplus b_i$$

$$C_{i+1}^0 = a_i b_i. \quad (1)$$

The j th iteration for the recursive addition is formulated by

$$S_i^j = S_i^{j-1} \oplus C_i^{j-1}, \quad 0 \leq i < n \quad (2)$$

$$C_{i+1}^j = S_i^{j-1} C_i^{j-1}, \quad 0 \leq i \leq n. \quad (3)$$

The recursion is terminated at k th iteration when the following condition is met:

$$C_n^k + C_{n-1}^k + \dots + C_1^k = 0, \quad 0 \leq k \leq n. \quad (4)$$

Now, the correctness of the recursive formulation is inductively proved as follows.

Theorem 1: The recursive formulation of (1)–(4) will produce correct sum for any number of bits and will terminate within a finite time.

Proof: We prove the correctness of the algorithm by induction on the required number of iterations for completing the addition (meeting the terminating condition).

Basis: Consider the operand choices for which no carry propagation is required, i.e., $C_i^0 = 0$ for $\forall i \in [0..n]$. The proposed formulation will produce the correct result by a single-bit computation time and terminate instantly as (4) is met.

Induction: Assume that $C_{i+1}^k \neq 0$ for some i th bit at k th iteration. Let l be such a bit for which $C_{l+1}^k = 1$. We show that it will be successfully transmitted to next higher bit in the $(k+1)$ th iteration. As shown in the state diagram, the k th iteration of l th bit state (C_{l+1}^k, S_l^k) and $(l+1)$ th bit state (C_{l+2}^k, S_{l+1}^k) could be in any of (0,0), (0,1), or (1,0) states. As $C_{l+1}^k = 1$, it implies that $S_l^k = 0$. hence, from (3), $C_{l+1}^{k+1} = 0$ for any input condition between 0 to 1 bits.

We now consider the $(l+1)$ th bit state (C_{l+2}^k, S_{l+1}^k) for k th iteration. It could also be in any of (0,0), (0,1), or (1,0) states. In $(k+1)$ th iteration, the (0,0) and (1,0) states from the k th iteration will correctly produce output of (0,1) following (2) and (3). For (0,1) state, the carry successfully propagates through this bit level following (3).

Thus, all the single-bit adders will successfully kill or propagate the carries until all carries are zero fulfilling the terminating condition. The mathematical form presented above is valid under the condition that the iterations progress synchronously for all bit levels and the required input and outputs for a specific iteration will also be in synchrony with the progress of one iteration. In the next section, we present an implementation of the proposed architecture which is subsequently verified using simulations.

IV. IMPLEMENTATION

A CMOS implementation for the recursive circuit is shown in Fig. 3. For multiplexers and AND gates we have used TSMC library implementations while for the XOR gate we have used the faster ten transistor implementation based on transmission gate XOR to match the delay with AND gates [4]. The completion detection following (4) is negated to obtain an active high completion signal (TERM). This requires a large fan-in n -input NOR gate. Therefore, an alternative more practical pseudo-nMOS ratioed design is used.

International Journal of Innovative Research in Science, Engineering and Technology

(A High Impact Factor & UGC Approved Journal)

Website: www.ijirset.com

Vol. 6, Issue 8, August 2017

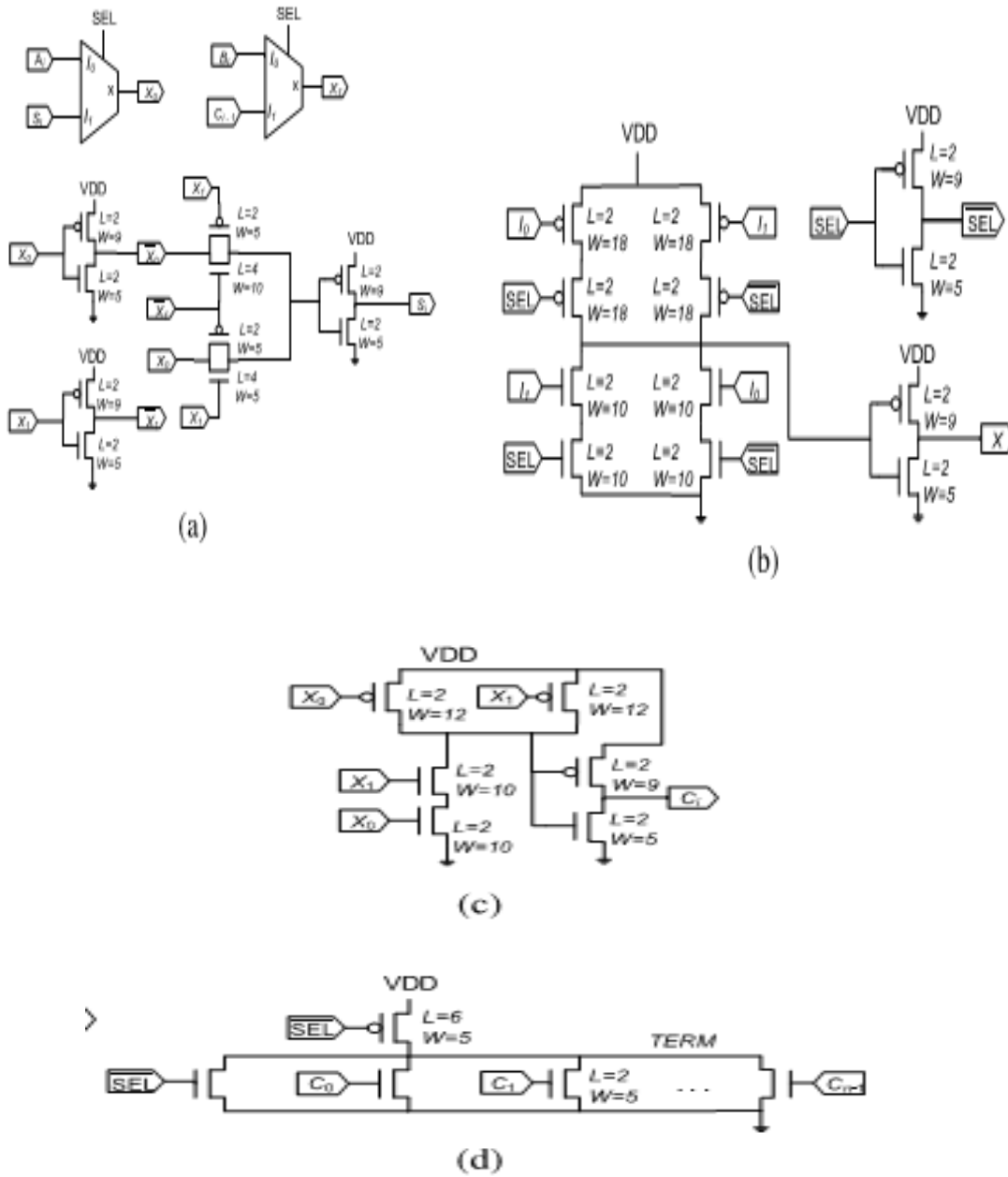

International Journal of Innovative Research in Science, Engineering and Technology

(A High Impact Factor & UGC Approved Journal)

Website: www.ijirset.com

Vol. 6, Issue 8, August 2017

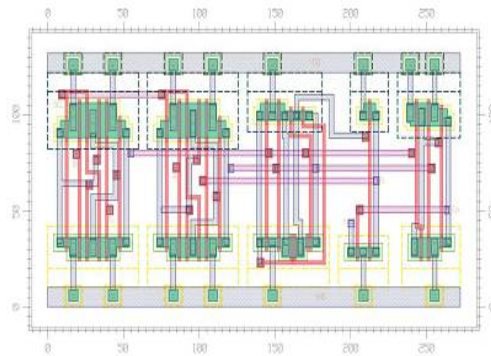
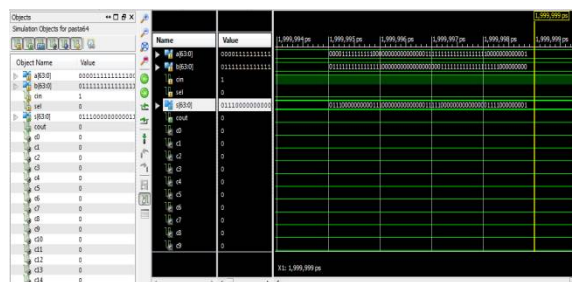

Fig. 3. CMOS implementation of PASTA. (a) Single-bit sum module. (b) 2x1 MUX for the 1 bit adder. (c) Single-bit carry module. (d) Completion signal detection circuit.

The resulting design is shown in Fig. 3(d). Using the pseudo-nMOS design, the completion unit avoids the high fan-in problem as all the connections are parallel. The pMOS transistor connected to VDD of this ratio-ed design acts as a load register, resulting in static current drain when some of the nMOS transistors are on simultaneously. In addition to the C_{in} , the negative of SEL signal is also included for the TERM signal to ensure that the completion cannot be accidentally turned on during the initial selection phase of the actual inputs. It also prevents the pMOS pull up transistor from being always on. Hence, static current will only be flowing for the duration of the actual computation

V. SIMULATION RESULTS

PASTA:



Synthesis Results: RTL Schematic:

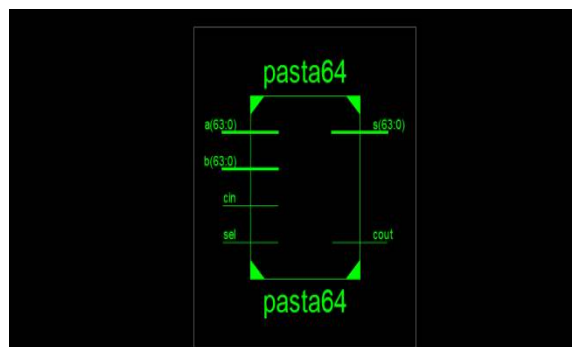

International Journal of Innovative Research in Science, Engineering and Technology

(A High Impact Factor & UGC Approved Journal)

Website: www.ijirset.com

Vol. 6, Issue 8, August 2017

Technology Schematic:

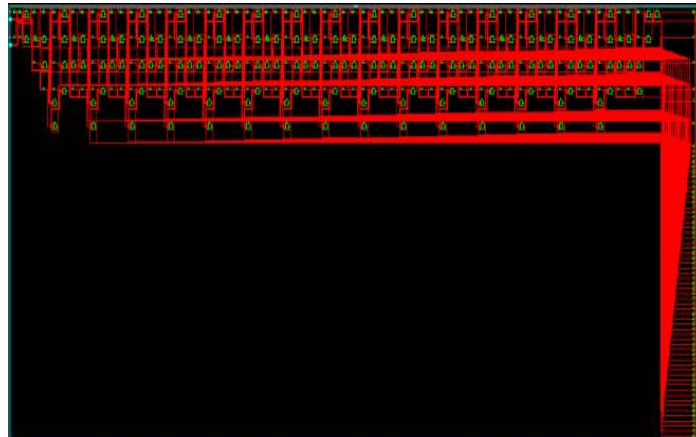

Design Summary:

pasta64 Project Status			
Project File:	sd_xise	Parser Errors:	No Errors
Module Name:	pasta64	Implementation State:	Synthesized
Target Device:	xc3s700a-fg484	• Errors:	No Errors
Product Version:	ISE 13.2	• Warnings:	7 Warnings (7 new)
Design Goal:	Balanced	• Routing Results:	
Design Strategy:	Xilinx Default (Unlocked)	• Timing Constraints:	
Environment:	System Settings	• Final Timing Score:	

Device Utilization Summary (estimated values)			
Logic Utilization	Used	Available	Utilization
Number of Slices	80	5888	1%
Number of 4 input LUTs	144	11776	1%
Number of bonded IOBs	195	372	52%

VI. CONCLUSION

In this paper, for the first time, we propose to exploit the dynamic pipelining property of self-timed pipeline to realize reconfigurable throughput/performance trade-off in pipelined adaptive signal processing systems. PRML read channel equalizer is considered in this work as a test vehicle. For practical implementation, we propose to use a zero-delay-overhead self-timed pipeline style that supports very high speed operation. We develop techniques to enable the application of zero-delay-overhead self-timed pipeline in this context and realize run-time pipeline depth control. Simulations under variable data rate scenarios demonstrate a significant performance gain. It is our hope that this work will motivate the real-life adaptive signal processing system designers to re-think their design from a self-timed perspective integrally at the algorithm, architecture, and circuit levels for potential system performance improvement.

REFERENCES

- [1] B. Widrow and S. D. Stearns, "Adaptive Signal Processing," Prentice Hall, 1985. IEEE vol. 26, no. 11, pp. 1651–1661, Nov. 1991.
- [2] S. Haykin, "Adaptive filter theory," Prentice Hall, 1996.
- [3] N. R. Shanbhag and K. K. Parhi, "Pipelined Adaptive Digital Filters," Kluwer, 1994.

International Journal of Innovative Research in Science, Engineering and Technology

(A High Impact Factor & UGC Approved Journal)

Website: www.ijirset.com

Vol. 6, Issue 8, August 2017

- [4] T. Williams, "Self-Timed Pipelines (Chapter 9 in Design of HighPerformance Microprocessor Circuits edited by A. Chandrakasan et al.)," John Wiley & Sons, 2000.
- [5] J. Sparso and S. Furber, "Principles of Asynchronous Circuit Design: A Systems Perspective," Kluwer Academic Publishers, 2002. IEEE International Conference on Computer Design: VLSI in Computers and Processors, Sept. 2002, pp. 454–457.
- [6] M. Singh, J. A. Tierno, A. Rylyakov, S. Rylov, and S. M. Nowick, "An adaptively-pipelined mixed synchronous-asynchronous digital FIR filter chip operating at 1.3 gigahertz," in Proc. Eighth International Symposium on Asynchronous Circuits and Systems, April 2002, pp. 84–95.
- [7] A. Efthymiou and J. D. Garside, "Adaptive pipeline depth control for processor power-management," in Proc. IEEE International Conference on Computer Design: VLSI in Computers and Processors, Sept. 2002, pp. 454–457.
- [8] T. E. Williams and M. A. Horowitz, "A zero-overhead self-timed 160-ns 54-b CMOS divider," IEEE Journal of Solid-State Circuits, vol. 26, no. 11, pp. 1651–1661, Nov. 1991.
- [9] T. D. Howell, W. L. Abbott, and K. D. Fisher, "Advanced read channels for magnetic disk drives," IEEE Transactions on Magnetics, vol. 30, no. 6, pp. 3807–3812, Nov. 1994.
- [10] C. Ruemmler and J. Wilkes, "An introduction to disk drive modeling," Computer, vol. 27, no. 3, pp. 17–28, March 1994.
- [11] Hitachi Global Storage Technologies, "Deskstar 120GXP OEM Specification v4.1," [http://www.hitachigst.com/tech/techlib.nsf/products/Deskstar 120GXP](http://www.hitachigst.com/tech/techlib.nsf/products/Deskstar%20120GXP), 2003.