

# **Correlation of Ratio of Ratio of Near Infrared Vs Infrared Photoplethysmograph Spectroscopy for the Non-Invasive Measurement of Haemoglobin**

Ashita Diwate<sup>1</sup>, Yogesh Kumar<sup>2</sup>, Dr. Sanjeev Kumar<sup>3</sup>, Prof. T. D. Shep<sup>4</sup>

P.G. Student, Department of Electronics and Communication Engineering, MIT Engineering College, Aurangabad,  
Maharashtra, India<sup>1</sup>

Junior Research Fellow, Bio-medical Instrumentation unit, CSIR-CSIO, Chandigarh, India<sup>2</sup>

Scientist, Bio-medical Instrumentation unit, CSIR-CSIO, Chandigarh, India<sup>3</sup>

Assistance Professor, Department of Electronics and Communication Engineering, MIT Engineering college,  
Aurangabad, Maharashtra, India<sup>4</sup>

**ABSTRACT:** Haemoglobin is one of the important factor in blood which can be used for various medical treatments and investigations of deceases. Quick results, low cost and comfort for patient are the basic needs of every technique and non-invasive technique fulfils all these requirements. Leading non-invasive technique is easiest technique for haemoglobin measurement. In this paper, we are discussing dual-wavelength haemoglobin measurement method for study and analysis of haemoglobin monitoring. Following principle of pulse oximeter, two wavelengths are used for reducing complications in analysis. Pulses of RED and IR signals are obtained and ratio of both AC and DC values of two signals are calculated. Ratio of ratio of RED and IR pulse values can give the strongest relationship with haemoglobin value. This relation can lead to accurate algorithm for calculation of haemoglobin value.

**KEYWORDS:** Haemoglobin, pulse-oximeter, non-invasive, photoplethysmography, NIR spectroscopy.

## **I. INTRODUCTION**

Haemoglobin value can be used for various prescriptions. When haemoglobin is measured in laboratory by taking out blood from body, then this method is said to be invasive method. This method is currently using in day to day life. Few drawbacks including this method are said to be requirement of time, painful process to patient and investment of cost as well as experienced manpower. To provide comfort to patient and avoiding those drawbacks, non-invasive technique can be used. Non-invasive measurement of blood is mean to be calculation of haemoglobin level in body without any extraction of blood from body. When blood flows from a body it carries oxygen molecules and passes it to tissues. Appropriate functioning of blood flowing in body tends to proper functioning of all organs in body[1]. For immediate knowledge of condition of patient, critical conditions in labour rooms as well as in operating theatre there is need of haemoglobin level[2]. Simultaneous and instant availability of haemoglobin values can be measured with the help of non-invasive method only. For the proper diagnosis of anemia which is related to haemoglobin concentration in body this method is useful. In addition, for treatment of dengue, it is needful[3]. Opinion of doctors are taken related to various medical camps carrying out in villages by different organization. According to survey, it is noted that many of patients do not want to do blood test because of pain in invasive method. Also, they told that it is long process and difficult to carry out haemoglobin measurement for every patient because of time requirement in this method. So, there is requirement of non-invasive method for overcoming all these problems.

# International Journal of Innovative Research in Science, Engineering and Technology

(A High Impact Factor & UGC Approved Journal)

Website: [www.ijirset.com](http://www.ijirset.com)

Vol. 6, Issue 8, August 2017

Haemoglobin concentration measurement is related to pulsatile motion in arterial blood. When Blood flows through body, it flows in systolic and diastolic conditions. Amount of blood volume is more in systolic state and decreases in diastolic state. Near infrared (NIR) spectroscopy and photoplethysmography techniques are used in measurement. When light passes through body, some of light get absorbed by body and some of light get transmitted. PPG technique can calculate blood volume in particular area[4]. It can identify change in blood volume. When light of particular wavelength  $\lambda$  passes through finger, change in volume of blood due to systolic and diastolic states happens. At one side of finger light source such as LED is placed and at receiving end detector is kept. Transmitted light produces AC and DC components which are used for haemoglobin measurement[5].

Many non-invasive methods and devices are available which needs to be calibrated and analysed for more accurate results. Devices such as Masimo Pronto-7 and Orsense NBM-200 are recently using in market. These devices follow different techniques and have to calibrate more for removing few drawbacks. Pronto-7 has 0.1% of biasing as compared to laboratory values with multiple wavelengths which make more complications in results where NBM-200 has 0.1g/dL of biasing[6, 7]. Few of techniques are being used such as Occlusion spectroscopy invented by Orsense Ltd defines that blood at a fingertip is occluded and then light made to pass through it to calculate haemoglobin concentration[8]. Pulse co-oximetry technique given by Masimo corporation consists of passing of light using multi-wavelength light source and reference signal for calculation of concentrations in blood. There are few errors occurs in techniques such as some improper physical construction of system as well as analysis[9].

Proposed method in this paper is a study for the biological analysis of blood haemoglobin monitoring. In this study, we proposed new method which can be used for calibration of system.

## II. METHODOLOGY

Method described is a dual wavelength pulse co-oximetry method. Two wavelengths are used following principle of pulse oximeter. According to principle of pulse oximeter, light is made to pass through fingertip and at the receiver side detector is placed to receive transmitted signals which will be used to calculate oxygen saturation and heart rate. Same principle is used to calculate haemoglobin value by using different wavelengths of light source and for developing algorithm which can give calibrated haemoglobin[10].

### *Selection of wavelength*

Concentration of Oxygenated (HbO<sub>2</sub>) and deoxygenated (HHb) blood values are required for measurement of oxygen saturation in body. This is the principle of pulse oximeter. But oxygen saturation is not directly proportional to haemoglobin concentration. So, we cannot define haemoglobin by relating it with oxygen saturation. This means we need to take different wavelengths values of light source from pulse oximeter. Haemoglobin concentration can be calculated at isobestic point as shown in figure which is at 810nm. At this point absorption coefficients of HHb and HbO<sub>2</sub> values are same. According to study, red blood cells consist of water. Above 1200nm, the values of HHb, HbO<sub>2</sub> and H<sub>2</sub>O are indistinguishable. So, we selected wavelength 1300nm which gives minimum distance between absorption coefficient of water and isobestic point[11].

# International Journal of Innovative Research in Science, Engineering and Technology

(A High Impact Factor & UGC Approved Journal)

Website: [www.ijirset.com](http://www.ijirset.com)

Vol. 6, Issue 8, August 2017

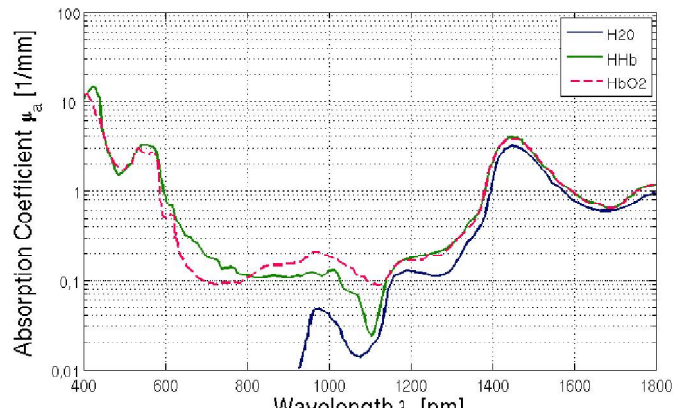

Figure 1: Absorption coefficient of HHb, HbO2 and H2O[11]

### Measuring method

As stated by principle, photoplethysmography is used for obtaining pulse values. IR and RED signals of wavelength 810nm and 1300nm gives values. For obtaining haemoglobin value, it is necessary calculate ratio of AC and DC values of both wavelengths. Taking ratio of ratio of both signals gives relation for haemoglobin value.

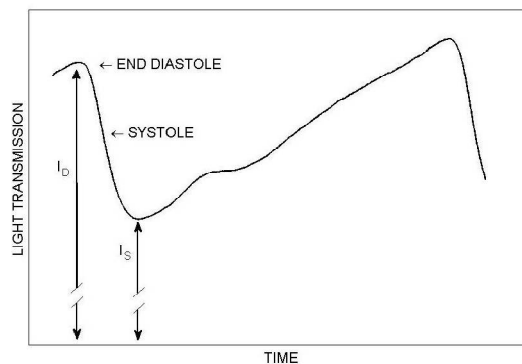

Figure 2: AC and DC values in pulse[12]

$$R = \frac{(I_D/I_S)_{Red}}{(I_D/I_S)_{IR}} = \frac{(\frac{AC+DC}{DC})_{Red}}{(\frac{AC+DC}{DC})_{IR}} \quad (1)$$

By using wavelengths in same equation,

$$R = \frac{I_{AC+DC,810nm} / I_{DC,810nm}}{I_{AC+DC,1300nm} / I_{DC,1300nm}} \quad (2)$$

Utilizing above equation it is possible to study and analyse relationship between haemoglobin and ration of ratio R. We will take multiple R values of different subjects of various ages and different haemoglobin values. R values of same person will be calculated for four to five times after some time span. Same procedure with few subjects will be carried out. Data collected can be used for observation and for investigation.

# International Journal of Innovative Research in Science, Engineering and Technology

(A High Impact Factor & UGC Approved Journal)

Website: [www.ijirset.com](http://www.ijirset.com)

Vol. 6, Issue 8, August 2017

## Basic model of methodology

The block diagram of the system for the measurement of haemoglobin, non-invasively, is shown in Fig. 2. The clip-on sensor to be mounted on a finger of a patient being tested houses two light emitting diodes (LEDs D1 and D2) on one side and a photodiode (D3 and D4) on the other side of a finger probe. LED D1 emits light at wavelength  $\lambda_1$  and D2 emits light at the wavelength  $\lambda_2$ . This consists of two main parts in which one is signal conditioning of experiment and other is data acquisition part. In signal conditioning part, data is collected, separated and amplified. Amplified signal separately given to DAQ acquisition system for analysing. In second part, i.e. in data acquisition part, by using module NI 9205 signal is analysed and processed. This module is configured with PC by installing drivers of module. So, analog data is converted into digital with the help of module and results can be processed and analysed on screen of PC.

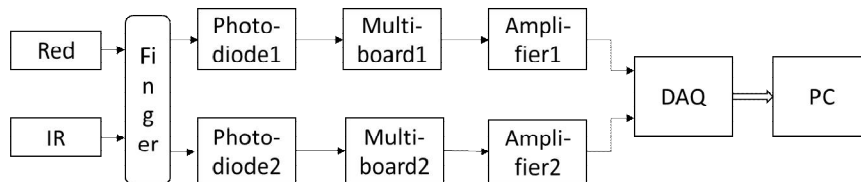

Figure 3: Basic model of experiment

## III. DESIGN OF EXPERIMENT

In first part of experiment, sensor is nothing but finger probe which have two light-emitting diodes of wavelength 810nm and 1300nm. At opposite side, i.e. at receiver side of probe two photo-detectors are placed, which have good responsivity for the wavelengths 810nm and 1300nm. Say 810nm as  $\lambda_1$  and 1300nm as  $\lambda_2$ . We are using different 2-channel multi-boards for two different photodiodes. One is connected to photodiode FDS100 having responsivity in the range of 0.5(A/W) at 810nm and other FGA10 having responsivity in the range of 0.8(A/W) for wavelength 1300nm. When the light is made to pass through finger with the help of two different light emitting diodes simultaneously, some light will be absorbed by the blood in tissues and some light will be transmitted. Transmitted light is received by photodiode. According to functioning of photodiode, light is converted in the form of current. This current can be converted into voltage level by using transimpedance amplifier, Multifunctional 2-channel amplifier board has been used for this purpose. To measure the changes of arterial blood at 1300nm which is infrared signal, high pass filter has been used to filter out DC component and IR signals penetrates more through skin so output power of photodiode for arterial blood at 1300nm is very less. This signal with lower power is further being amplified by using low power, dual operational amplifier (LM358) with gain of 50. The received signal includes noise in original signal due to electromagnetic interference which can be cancelled by using low pass filter with cut off frequency of 5Hz.

Schematic diagram of circuit is given in figure 3. Trans-impedance amplifier, high pass filter and low pass filter in circuit is mentioned in diagram. There are two outputs, output1 and output2. Output1 is for IR led and output2 is for RED led. By using following schematic, we will get clear and visible IR and RED-light signals. This is whole hardware setup for experiment.

# International Journal of Innovative Research in Science, Engineering and Technology

(A High Impact Factor & UGC Approved Journal)

Website: [www.ijirset.com](http://www.ijirset.com)

Vol. 6, Issue 8, August 2017

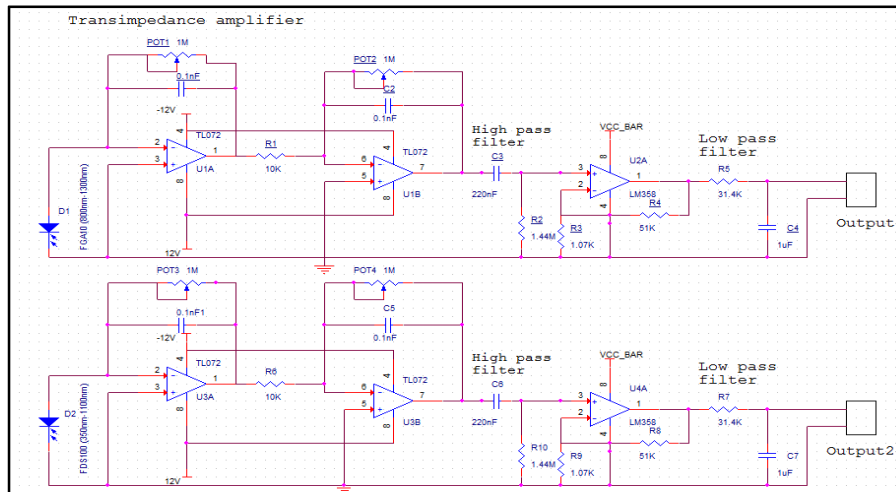

Figure 3: Schematic diagram for experiment

## Data acquisition using LabVIEW

In the second part of experiment i.e. in data acquisition part, signals coming from amplifiers with some intensity are connected to NI 9205 with the help of connecting wires. Compact DAQ system is connected to PC with the help of USB cables. Here, analog values are converted into digital data. The processing and display software is written in LabVIEW 2016, from National Instruments, and executes on PC. Using above equation, ratio of ratio is calculated by taking negative and positive peaks of the signals. These peaks will be measured and ratio of both the peaks will be calculated. These both ratios are again used for taking their ratio. Calculated ratio of ratio will be our final results for analysis and observation for future work.

## IV. EXPERIMENTAL RESULTS

The experimental has been an exploratory one, which provides an overview of the working the most basic and simplified way to measure haemoglobin non-invasively. The photo-detector signal is amplified and divided into the necessary parameters to compute the ratio of ratios which is used along with the absorptivity values to compute the haemoglobin. The whole instruments have been designed to calculate ratio of ratios of AC compound to DC compound of 810nm and 1300nm wavelengths. During the study following work is carried out.

Given figure shows the separate signals obtaining from 810nm and 1300nm on digital storage oscilloscope. These signals are of different amplitude because RED signals get observed more by blood as compared with IR signal. So, Red signal have grater amplitude and IR signal have less amplitude. Both signals are used for further analysis in which these voltages are connected to DAQ system.

# International Journal of Innovative Research in Science, Engineering and Technology

(A High Impact Factor & UGC Approved Journal)

Website: [www.ijirset.com](http://www.ijirset.com)

Vol. 6, Issue 8, August 2017

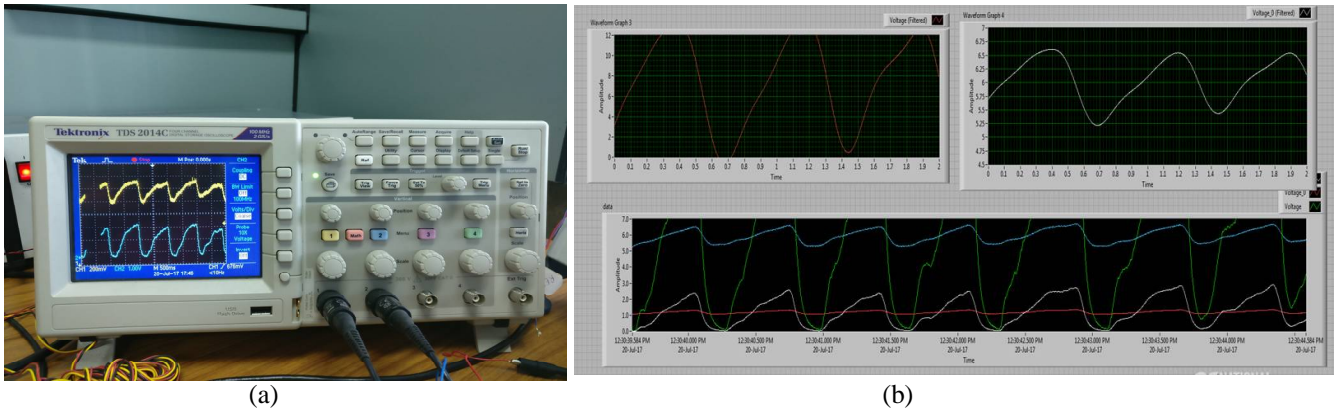

Figure 4: (a) RED and IR signals on CRO (b) RED and IR signals in LabVIEW

To acquire PPG signal, work is done in LabVIEW using DAQ NI-USB-9205. The calculated ratios of ratio of AC component to DC component of 810nm and 1300nm wavelength and acquire PPG signal are shown in figure 37. Waveform graph for the acquired signal is shown. Filtered signals of both RED and IR calculates beat per minute and ratio of ratio. Calculations are done using program and real-time inputs for calculation of final results. As shown in figure 5 beat per minute (heart rate) and ratio of ratio is calculated.

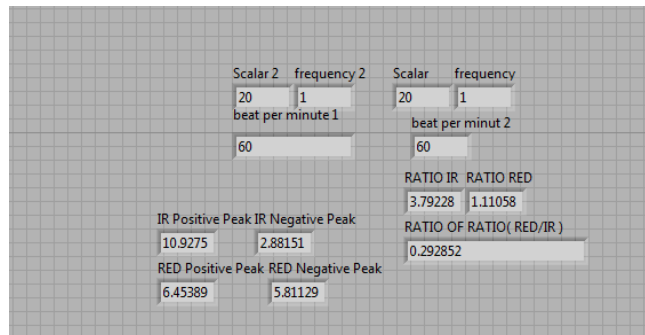

Figure 5: Beat per minute and ratio of ratio

For more detailed analysis we have taken readings of few subjects. Haemoglobin value of all subjects is calculated by using invasive method and using above program we have calculated ratio of ratio. Taking more than five trials of every subject, repeated value of ratio of ratio are calculated as shown in table. This ratio of ratio values denotes different values for different level of haemoglobin.

# International Journal of Innovative Research in Science, Engineering and Technology

(A High Impact Factor & UGC Approved Journal)

Website: [www.ijirset.com](http://www.ijirset.com)

Vol. 6, Issue 8, August 2017

Table 1: Observation table

Subject no.	Gender	Age	Weight	Hb value	Trials	Ratio of ratio	Range	Pulse rate
Subject 1	Female	24years	49Kg	13.1g/dL	1 <sup>st</sup> trial	0.3896	0.353369- 0.3896	84-87
					2 <sup>nd</sup> trial	0.3533		75-81
					3 <sup>rd</sup> trial	0.359427		81-84
					4 <sup>th</sup> trial	0.367807		84-87
					5 <sup>th</sup> trial	0.353369		75-81
Subject 2	Male	27years	63Kg	12.4g/dL	1 <sup>st</sup> trial	0.251184	0.246353- 0.254095	99-102
					2 <sup>nd</sup> trial	0.254095		99-105
					3 <sup>rd</sup> trial	0.246353		99
					4 <sup>th</sup> trial	0.250659		93-96
					5 <sup>th</sup> trial	0.250739		102-105
Subject 3	Male	23years	52kg	11.6g/dL	1 <sup>st</sup> trial	0.132184	0.122562- 0.13334	63-69
					2 <sup>nd</sup> trial	0.147542		75
					3 <sup>rd</sup> trial	0.113129		66-69
					4 <sup>th</sup> trial	0.122562		66
					5 <sup>th</sup> trial	0.13334		66-69
Subject 4	Male	25years	78kg	12.6g/dL	1 <sup>st</sup> trial	0.240511	0.240102- 0.255489	81-87
					2 <sup>nd</sup> trial	0.255489		75-81
					3 <sup>rd</sup> trial	0.240102		78-81
					4 <sup>th</sup> trial	0.24956		111-120
					5 <sup>th</sup> trial	0.250166		111-114

## V. CONCLUSION

A LED based haemoglobin measurement system (HMS) has been developed that is able to measure PPG-signals continuously of two specified wavelengths namely 810nm and 1300nm. Results denotes that there is strong relation between haemoglobin and ratio of ratio. According to analysis it is observed that ratio of ratio is directly proportional to haemoglobin value. Initial results for a non-invasive in-vivo measurement of the haemoglobin concentration of whole blood, indicate the possibility of accurately determining haemoglobin concentration using such a method. Using accurate algorithm and this relation it is possible to calculate accurate haemoglobin value.

## REFERENCES

- [1] R. J. Hill and W. Koningsberg, "The structure of human hemoglobin," *J Biol Chem*, vol. 237, pp. 3151-3156, 1962.
- [2] M. O'Reilly, "Understanding noninvasive and continuous hemoglobin monitoring," *Critical care medicine*, vol. 41, p. e52, 2013.
- [3] L. Berkow, S. Rotolo, and E. Mirski, "Continuous noninvasive hemoglobin monitoring during complex spine surgery," *Anesthesia & Analgesia*, vol. 113, pp. 1396-1402, 2011.
- [4] G. Reich, "Near-infrared spectroscopy and imaging: basic principles and pharmaceutical applications," *Advanced drug delivery reviews*, vol. 57, pp. 1109-1143, 2005.
- [5] J. Allen, "Photoplethysmography and its application in clinical physiological measurement," *Physiological measurement*, vol. 28, p. R1, 2007.
- [6] E. Hadar, O. Raban, T. Bouganim, K. Tenenbaum-Gavish, and M. Hod, "Precision and accuracy of noninvasive hemoglobin measurements during pregnancy," *The Journal of Maternal-Fetal & Neonatal Medicine*, vol. 25, pp. 2503-2506, 2012.

## International Journal of Innovative Research in Science, Engineering and Technology

(A High Impact Factor & UGC Approved Journal)

Website: [www.ijirset.com](http://www.ijirset.com)

Vol. 6, Issue 8, August 2017

- [7] C. S. Bruells, A. K. Menon, R. Rossaint, A. Goetzenich, M. Czaplík, N. Zoremba, *et al.*, "Accuracy of the Masimo Pronto-7® system in patients with left ventricular assist device," *Journal of cardiothoracic surgery*, vol. 8, p. 159, 2013.
- [8] M. Pinto, M. L. Barjas - Castro, S. Nascimento, M. A. Falconi, R. Zulli, and V. Castro, "The new noninvasive occlusion spectroscopy hemoglobin measurement method: a reliable and easy anemia screening test for blood donors," *Transfusion*, vol. 53, pp. 766-769, 2013.
- [9] J. M. Goldman, M. T. Petterson, R. J. Kopotic, and S. J. Barker, "Masimo signal extraction pulse oximetry," *Journal of clinical monitoring and computing*, vol. 16, pp. 475-483, 2000.
- [10] J. G. Webster, *Design of pulse oximeters*: CRC Press, 1997.
- [11] U. Timm, E. Lewis, G. Leen, D. McGrath, J. Kraitl, and H. Ewald, "Non-invasive continuous online hemoglobin monitoring system," in *Sensors Applications Symposium (SAS), 2010 IEEE*, 2010, pp. 131-134.
- [12] M. Nitzan, S. Noach, E. Tobal, Y. Adar, Y. Miller, E. Shalom, *et al.*, "Calibration-Free Pulse Oximetry Based on Two Wavelengths in the Infrared—A Preliminary Study," *Sensors*, vol. 14, pp. 7420-7434, 2014.