

## International Journal of Innovative Research in Science, Engineering and Technology

(A High Impact Factor, Monthly, Peer Reviewed Journal)

Visit: [www.ijirset.com](http://www.ijirset.com)

Vol. 6, Issue 12, December 2017

# Review on Design of a Control system for Robots Using FPGA

Uzma Zabeen Shaikh<sup>1</sup>, Shraddha Bawangade<sup>2</sup>, Ahmadi Tahseen<sup>3</sup>, Saniya Anjum<sup>4</sup>, Prof. M. Nasiruddin<sup>5</sup>

B.E Student, Department of Electronics and Telecommunication Engineering, ACET, Sadar, Nagpur, India<sup>1</sup>

B.E Student, Department of Electronics and Telecommunication Engineering, ACET, Sadar, Nagpur, India<sup>2</sup>

B.E Student, Department of Electronics and Telecommunication Engineering, ACET, Sadar, Nagpur, India<sup>3</sup>

B.E Student, Department of Electronics and Telecommunication Engineering, ACET, Sadar, Nagpur, India<sup>4</sup>

Associate Professor & HOD, Electronics and Telecommunication Engineering, ACET, Sadar, Nagpur, India<sup>5</sup>

**ABSTRACT:** Since the advent of robots, work has been shared between man and machine. But, as robots become more technologically advanced and autonomous, they learn how to do jobs faster and better than humans. Their precision, intelligence and endless energy levels make them the perfect employees for a wide variety of jobs that humans just can't afford to do. A robot that avoid obstacles and allows knowing the distance from such obstacles to the mobile robot was built. The basic system design till date consists of two ultrasound transducers placed in the front and the back of the mobile, and the infrared ones placed on the sides. This configuration gives autonomy to the robot, allowing the obstacles evasion and avoiding the collision with objects around to generate possible escape routes. FPGA chip's high reliability, good expansibility, easy to transplant and the precise ultrasonic measurement, obstacle avoidance will has good market prospects because of its high degree of flexibility, accuracy, real-time. The FPGA was used in the basic structure to receives the digitized values from the sensors, formats the data and performs operations that will throw as results the control signals that will indicate to each motor the movement they must follow to avoid an obstacle according to the measured distance. The basic idea of this paper is touse Verilog HDL language to implement combining FPGA chip with ultrasonic ranging module and control motor drive to achieve the automatic obstacle avoidance function and to add more transducer in order to enhance the application of the system by introducing light intensity, sound detection, depth detection, temperature and fire sensing module.

**KEYWORDS:** Robot, FPGA (Field Programmable Gate Array), Transducer, Sensor, Verilog HDL.

### I. INTRODUCTION

Along with the rapid development of science and technology, ultrasonic ranging is widely applied in industry, agriculture, transportation, environment, safety protection, the energy measurement and other scientific fields. The performance indexes of ultrasonic ranging such as measuring precision, measuring distance and measuring reliability and so on, has a very important role to improve the control precision and reliability of the related application system, enhance production efficiency, and promote the development of science and technology [1]. Although the cost is low, the measurement precision of the FPGAs (Field Programmable Gate Arrays) are widely used in real time tasks in recent years. FPGA is high density field programmable logic devices not only solves the lack of custom circuits, but overcomes the shortcomings of original programmable gate device that the gate circuits are limited. FPGA has many features such as perfect efficiency, portable, easy to operate, good secrecy performance, subtle real-time performance, high integration [3]. The main advantage of FPGA based real time systems is its ability to handle concurrent tasks. The hardware description languages allow programmers to think in different ways. The ability to run concurrent tasks limits only by the hardware resources. This concurrency is very helpful in mobile robots. A robot with number of sensors and numbers of motors could be controlled concurrently with use of a single FPGA chip. So that, this is a small attempt to implement a mobile robot which avoids obstacles with use of range sensors and wheeled motors. The mobile robot

# International Journal of Innovative Research in Science, Engineering and Technology

(A High Impact Factor, Monthly, Peer Reviewed Journal)

Visit: [www.ijirset.com](http://www.ijirset.com)

Vol. 6, Issue 12, December 2017

platform can move forward, backward, turn right, left. With use of the three range sensors the robot avoids obstacles. The algorithm is developed using combinational logic. This obstacle avoidance system can be implemented in medical assertive devices, industrial robots and outdoor / indoor navigation robots. While a microprocessor could be used for real time systems, it lacks the ability to parallel data processing in time critical applications such as an obstacle avoidance system. This system adopts FPGA as the main control chip which controls the driver module through the real-time distance measured by ultrasonic module, and then leads to the avoidance of obstacle intelligently. This design employs the L293D motor driver module which makes the circuit work with high stability.

## II. RELATED WORK

A robot capable of locomotion carries an FPGA board in charge of signal processing and control signal generation. Sensors send information to an analogical to digital converter and this information passes to the FPGA, when a control signal is generated, the information goes to a digital to analog converter that finally sends orders to the system motors according to Figure 1.

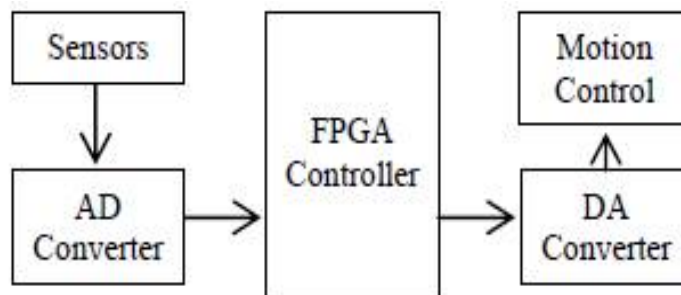

Figure 1 : Basic block diagram of system

An oscillator circuit is in charge of providing a 5 volts signal with a frequency of 50 KHz to the SRF05 ultrasound sensor, which is polarized with 5 volts dc. The SRF05 output is a 5 volts signal with a variable period that depends on the distance from the robot to the obstacle, this signal is treated to obtain a voltage value that is proportional to the distance to the object location. The figure 2 shows the sensor and its emission pattern



Figure 2 : Sensor and its emission pattern

## International Journal of Innovative Research in Science, Engineering and Technology

(A High Impact Factor, Monthly, Peer Reviewed Journal)

Visit: [www.ijirset.com](http://www.ijirset.com)

Vol. 6, Issue 12, December 2017

In order to conditioning the input signal it is necessary to design the circuits for the oscillator, the converter from frequency to voltage, the analog to digital and digital to analog converters to interact with the FPGA. For the software, the input, output and control routines have been developed. The hardware design was planned as a modular system considering all the printed circuits, the coupling of stages, and the electrical signal conditioning [5-7].

The software was developed considering that the robot includes two ultrasound transducers [8, 9], one in the frontal part and other one in the back part of the robot. Furthermore, the robot includes two infrared transducers, one placed on the right side and the other on the left one. The robot has been provided with two servomotors that control the course of the mobile. The software was developed using VHDL and the obtained results are adapted to the system requirements. A procedure for display the distance obtained by the FPGA board, measured in meters has been developed. Once frequency measured by the SRF05 is taken, the conversion of this frequency to the equivalent distance is programmed using a clock that counts the bits sent in a period. In order to take the distance between the mobile robot and the obstacle a range is used. If the distance is less than 20 cm several conditions are considered to calculate the distance. In this way it is possible to elude the obstacles and measure distance between objects and the mobile. A random function decides which direction must be taken, after verifying that no obstacles exist in more than 20 cm around. The voltage signal of 5 V in amplitude and variable period passes through one block that provides a linear voltage signal within a range of 0.02 and 5 volts. This voltage is converted to its correspondent digital equivalent. This signal is interpreted as the distance to the object. The prototype is intended to provide to the robot with the measured distance from where a certain obstacle is found in order to determine the actions that allow him to evade such an object, depending on the environment in which the robot is immersed. Figure 5 shows the block diagram for the data flow of the general system.

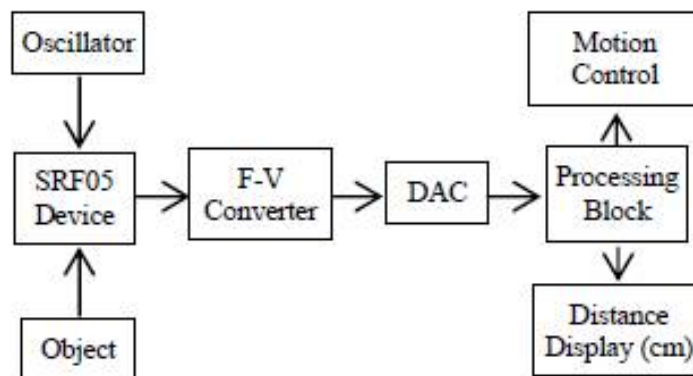

**Figure 3 : Data flow diagram of the system.**

### IV. PROPOSED STRUCTURE

The idea of this work is to enhance the application of basic structure by interfacing more module with the basic one. The system includes two ultrasound transducers, one in the frontal part and other one in the back part of the robot. This ultrasound transducers detect an obstacles in the range of 5cm to 500cm. The system also includes four infrared transducers, two placed on the right and the left side of the robot and two placed on the bottom left and bottom right of the robot. This infrared transducers detect an obstacles in the range of 1cm to 40cm. These sensors sends information to the FPGA board, when a control signal is generated. The signals is stimulated on the FPGA board. The signals is then passes to the system motor according to the block diagram displayed below.

## International Journal of Innovative Research in Science, Engineering and Technology

(A High Impact Factor, Monthly, Peer Reviewed Journal)

Visit: [www.ijirset.com](http://www.ijirset.com)

Vol. 6, Issue 12, December 2017

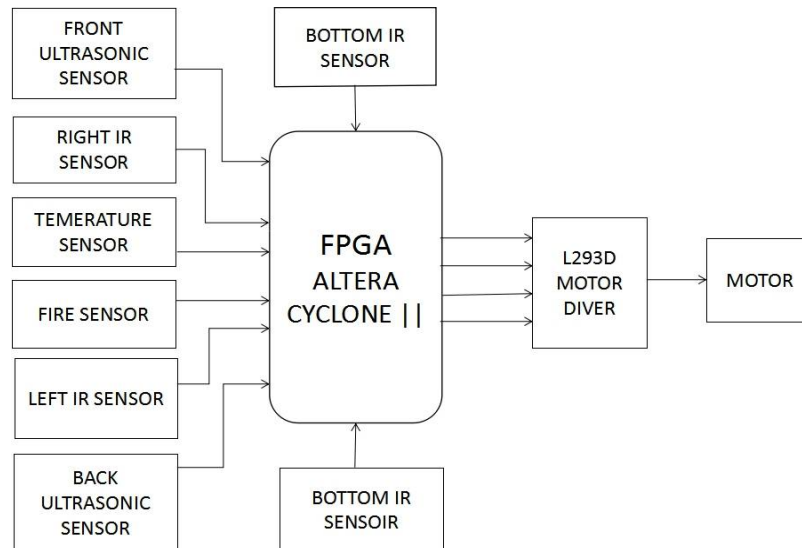

**Figure 3: Block diagram of proposed structure**

An infrared sensor is an electronic device, that emits in order to sense some aspects of the surroundings. An IR sensor can measure the heat of an object as well as detects the motion. These types of sensors measures only infrared radiation, rather than emitting it that is called as a passive IR sensor. Usually in the infrared spectrum, all the objects radiate some form of thermal radiations. These types of radiations are invisible to our eyes, that can be detected by an infrared sensor. The emitter is simply an IR LED (Light Emitting Diode) and the detector is simply an IR photodiode which is sensitive to IR light of the same wavelength as that emitted by the IR LED. When IR light falls on the photodiode, the resistances and these output voltages, change in proportion to the magnitude of the IR light received. An infrared sensor circuit is one of the basic and popular sensor module in an electronic device. This sensor is analogous to human's visionary senses, which can be used to detect obstacles and it is one of the common applications in real time. A motor driver is an integrated circuit chip which is usually used to control motors in autonomous robots. Motor driver act as an interface between Altera cyclone II and the motors. The most commonly used motor driver IC's are from the L293 series such as L293D, L293NE, etc. These ICs are designed to control 2 DC motors simultaneously. L293D consist of two H-bridge. H-bridge is the simplest circuit for controlling a low current rated motor. We will be referring the motor driver IC as L293D only. Ultrasonic sensor operates at 45 degree angle as well as in different conditions. The sensor cannot receive correct signals at corners. And this is a combinational logic the robot cannot take intelligent decisions as well. The same obstacle avoidance robot can be developed to an efficiently working robot. There are two things need to be done. The tasks such as the ultrasonic distance reading and motor control can be made responsible for the FPGA chip and then the algorithm can be programmed. Then the algorithms can be made more intelligent and efficient. While the sensors and actuators are handled by the FPGA itself without any delay. The other requirement is to introduce more sensors into the mobile robot like temperature sensor and fire sensor, so that, more resourceful decisions could be taken by the robot at the time of emergency.

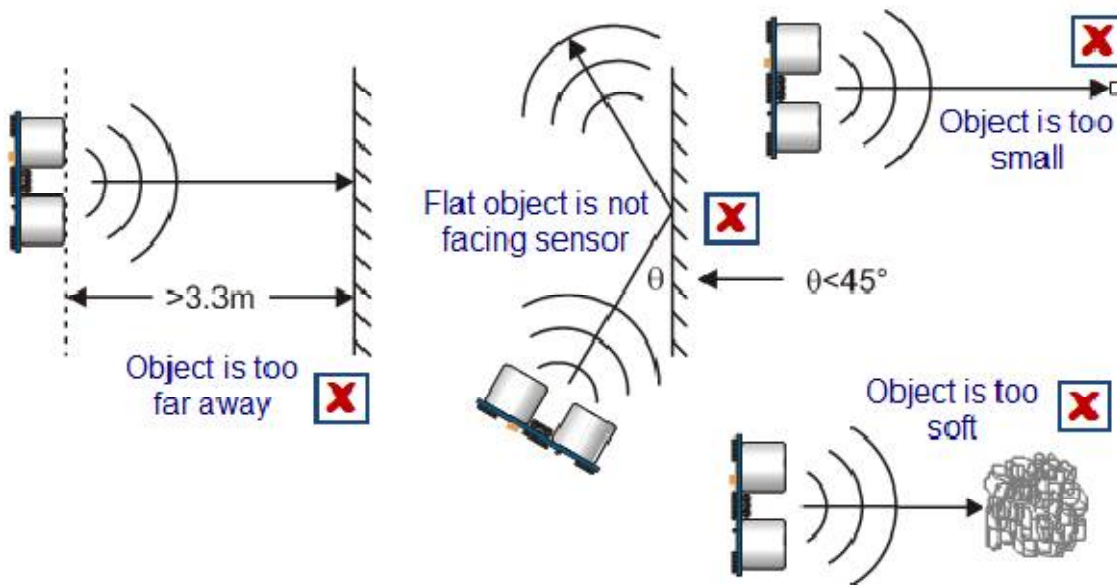

**Figure 4: Ultrasonic operation in every condition**

## V. CONCLUSION

The developed system proposes the solution to the problem of determining and calculating distances thereby connecting extra module to the basic structure to enhance the application of the project. The electronic systems provide information to the mobile robot to give him autonomy in the decisions making process, which depends on the assigned task and the environment where the robot is immersed. The system includes a reprogrammable device in order to accelerate the application; this element provides enough flexibility for adjustment to new requirements or new algorithms.

## REFERENCES

- [1] T.Schlegl, T. Bretterkieber, M. Neumayer and H. Zangl, "A Novel Sensor Fusion Concept for Distance Measurement in Automotive Applications," Graz University of Technology, Austria, 2010, pp. 755-778.
- [2] JingZhuo Shi, "Ultrasonic motor motion control theory and technology," Beijing: Science Press, 2011.
- [3] Wenxiang Zhang, Zhijn Li and Zihong Zhang, "SCM system design and development of the tutorial," Beijing: Electronic Industry Press, 2011.
- [4] R. A. Sigwalt, C. O. R. Negrão, and P. C. Tonin, Influência do Escoamento no Processo de Incrustação. Departamento Acadêmico de Mecânica, Centro Federal de Educação Tecnológica do Paraná, Seminário de Ciência e Tecnologia, 2002. (In Portuguese).
- [5] J. L. Rose, "Recent advances in guided wave NDE," in Proc. IEEE Ultrasound. Symp., 1995, pp. 761-770.
- [6] J. Barshinger, J. L. Rose, and M. J. Avioli, Jr., "Guided wave resonance tuning for pipe inspection," J. Press. Vessel Technol., vol. 124, no. 3, Aug. 2002, pp. 310-330.
- [7] Xilinx: <http://www.xilinx.com>
- [8] Bates, M., *Interfacing PIC microcontrollers*, Newnes Edition, USA 2006.
- [9] Lovine J., *PIC Microcontroller Project Book*, Tab Books, USA, 2000.
- [10] Lovine J., *PIC Robotics A Beginner's Guide to Robotics Projects Using the PICmicro*, McGraw-Hill, USA, 2004.
- [11] K. R. Lohr and J. L. Rose, "Ultrasonic guided wave and acoustic impact methods for pipe fouling detection," J. Food Eng., vol. 56, no. 4, Mar. 2003, pp. 315-324.
- [12] C. M. Fortunko, "Generation and reception of ultrasonic signal—Ultrasonic testing equipment," in *Nondestructive Testing Handbook*, 2nd ed., vol. 7, Amer. Soc. Nondestructive Testing, Columbus, OH, 1991.