

H Bridge DC Motor Driver Design and Implementation with Using dsPIC30f4011

Tolga Özer¹, Sinan Kıvrak², Yüksel Oğuz³

Department of Electric and Electronic Engineering, Afyon Kocatepe University, Merkez/Afyonkarahisar, Turkey

Department of Electric and Electronic Engineering, Ankara Yıldırım Beyazıt University, Ankara, Turkey

Department of Electric and Electronic Engineering, Afyon Kocatepe University, Merkez/Afyonkarahisar, Turkey

ABSTRACT: Today DC motors are used commonly at lots of electrical application. DC drive systems are often used in many industrial applications such as robotics, actuation and manipulators. These motors are easy to drive, fully controllable and readily available in all sizes and configurations. When examined these applications DC motors are needed to be operated on variable or constant speed with forward or reverse operation. There are many control techniques to obtain control of different speeds. For this controlling process the electric drive systems are used frequently. Industrial applications are increasingly required to meet higher performance and reliability requirements. The DC motor is an attractive piece of equipment in many industrial applications requiring variable speed and load characteristics due to its ease of controllability. Microcontrollers provide a suitable means of meeting these needs.

In this paper, H bridge DC motor driver is designed and implemented. H bridge circuit is used for controlling DC motor speed and rotating side. The H bridge driver Mosfets are driven by a high frequency PWM signal. Controlling the PWM duty cycle is equivalent to controlling the motor terminal voltage, which in turn adjust directly the motor speed. DC motor driver is controlled with using the dsPIC30f4011 microcontroller. PWM signals are generated at dsPIC30f4011 and applied to DC motor driver circuit. Microcontrollers has been investigated for different speed control of DC motor.

KEYWORDS: DC Motor, dsPIC30f4011 , H Bridge, PWM Control.

I. INTRODUCTION

Brushed DC motors are commonly used lots of electrical systems or control systems. Such as brushed DC motor is found at automotive control systems, ink jet printers, robotic applications, electric trains, disabled wheelchairs and battery powered hand-drills. Brushed DC motors are preferred commonly due to its simplicity and cost [1].

DC motors have to be controlled at the DC motor applications DC motor is needed to be operated with desired speeds, reverse or forward motion for different time periods. To control these types of parameters of the motor, the drive circuit is needed to design. A brushed DC motor is very easy to control and DC motor does not require an external driver to operate. Speed control of brushed DC motor is also easy because the voltage-speed characteristic of brushed DC motor is relatively linear [1].

Generally DC motors try to control with a variable potentiometer or variable resistor connected to a transistor. In the control method where transistors are used the main problem is heating of these transistors. Because of heating the transistors system waste the power to outside so this situation is decrease the efficiency of this motor driving system. To remove this disadvantage Pulse Width Modulation PWM DC motor control method can be used. PWM DC motor control method adjust the motor speed by short pulses. These PWM pulses fill rate is named as "Duty Cycle".

International Journal of Innovative Research in Science, Engineering and Technology

(An ISO 3297: 2007 Certified Organization)

Vol. 6, Special Issue 10, May 2017

According to Duty Cycle speed of the motor can be changed. If the Duty Cycle is high, the motor turns faster if it is low then motor turns more slowly [2].

In the past works there can be seen lots of works related with DC brushed motor speed control. But these driver circuits works in only one direction. The polarity of the voltage applied to the motor must be changed to change the direction of rotation of the motor. However suddenly change the direction of the motor may damage the motor. This situation can cause a big current surge on the system. Motor driver can be burned out also this current surge causes big electrical and mechanical stresses on the DC motor itself[3-6]. Jamal A. Mohammed designed and implemented motor bi-directional DC control circuit using Pulse Width Modulation (PWM) based on an operational amplifier model LM324 [7]. Nicolai and Castagnet have shown in their study how a microcontroller can be used for speed control. The operation of the system can be summarized as: the drive form a rectified voltage, it consists of chopper driven by a PWM signal generated from a microcontroller unit[8].M. Rylee discussed how to use the Enhanced, Capture, Compare, and PWM (ECCP) on the PIC16F684 for bi-directional brushed DC (BDC) motor control[9]. R. Karthick designed a circuit allowed controlling the speed of a DC motor from PC's parallel port[10]. The PC used a software program to control the speed of the motor. M. George proposed the speed controller of a separately excited DC motor with varying armature voltage[11].

In this study contains a designed brushed DC motor H bridge control circuit. Designed circuit overcomes big electrical and mechanical stresses problems due to current surge at DC motor. The objective of this paper is to explore the approach of designing a microcontroller based closed loop controller. The interface circuit and the software are all designed to achieve a better performance. Motor speed is controlled using a potentiometer and direction of the motor is controlled by means of button on the control card. If the button is pressed the motor slow down first and stop before changing direction. This DC motor driver circuit contains a current sensor. This sensor used for measuring DC motor current and to prevent drawing high current from source. Hence DC motor is protected from high current due to short circuiting or overloading.

II. MATHEMATICAL FORMULATION FOR A SEPARATELY EXCITED D.C MOTOR

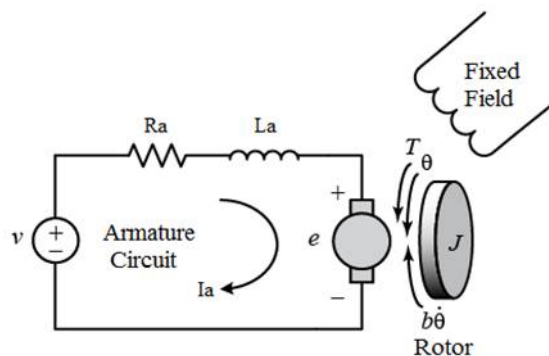

Figure 1. DC Motor Equivalent Circuit

Under steady-state operations, a time derivative is zero. Assuming the motor is not saturated. For field circuit,

$$V_f = i_f \cdot R_f + L_f \frac{di_f}{dt} \tag{1}$$

Rotation of the armature conductors in the flux field causes an electro motive force. to be induced in the armature circuit of such polarity as to oppose the flow of armature current. This induced e.m.f. is usually known as the reverse e.m.f. or back e.m.f. where ω is the instantaneous speed. Taking time average values, for steady state operation, results in:

International Journal of Innovative Research in Science, Engineering and Technology

(An ISO 3297: 2007 Certified Organization)

Vol. 6, Special Issue 10, May 2017

$$e = K_E \cdot \Phi \cdot \omega \quad (2)$$

For a separately excited D.C motor, the armature instantaneous voltage equation is given as:

$$v = i_a \cdot R_a + L_a \frac{di_a}{dt} + e \quad (3)$$

For steady state operation, the inductive effects are usually negligibly for small value.

This is justifiable since the D.C motor used has either inter-poles or compensating winding to minimize the effects of armature reaction, so the armature voltage equation is reduced to:

$$V_a = I_a \cdot R_a + e \quad (4)$$

The armature circuit,

$$V_a = I_a \cdot R_a + K_E \cdot \Phi \cdot \omega \quad (5)$$

The motor speed can be easily derived:

$$\omega = \frac{V_a - I_a \cdot R_a}{K_E \cdot \Phi} \quad (6)$$

If R_a is a small value (which is usual), or when the motor is lightly loaded, i.e. I_a is small,

$$\omega = \frac{V_a}{K_E \cdot \Phi} \quad (7)$$

That is if the field current is kept constant, the speed motor speed depends on the supply voltage. These observation leads to the application of variable DC voltage to control the speed and torque of DC motor.

III.PWM TECHNIQUE

Generally DC motors direction of rotation and speed are controlled with using PWM signals. By means of PWM signals applied voltage to DC motor windings can be changed. This changing is seen as a speed on the motor. The voltage increasing causes the speed increasing.

In many applications simple voltage regulation would cause a lot of power loss in control circuit, so *Pulse Width Modulation (PWM)* is used in many DC motor controlling application. The rapid rising and falling edges ensure that the semiconductor power devices are turned on or turned off as fast as practically possible to minimize the switching transition time and the associated switching losses.

The average value of voltage fed to the load is controlled by turning the switch between supply and load ON and OFF at a fast pace. The longer the switch is ON compared to the OFF periods, the higher the power supplied to the load is. The term duty cycle describes the proportion of ON time to the regular interval or period of time, a low duty cycle corresponds to low power, because the power is OFF for most of the time. Duty cycle is expressed in percent 100% being fully ON.

Figure (2) illustrates the PWM signal logic. This “on” time is referred to as the “duty cycle” and is stated as a percentage, calculated as:

$$Duty\ Cycle\ (\%) = \frac{OnTime}{Period} \times 100 \quad (8)$$

Figure (2) shows a duty cycle of 25%, 50%, and 75% with the resulting average perceived voltage of these PWM signals equal to different voltage levels. The frequency of the PWM drive signal is calculated by taking the reciprocal of the period [12]:

$$PWM\ Frequency = \frac{1}{Period} \quad (9)$$

International Journal of Innovative Research in Science, Engineering and Technology

(An ISO 3297: 2007 Certified Organization)

Vol. 6, Special Issue 10, May 2017

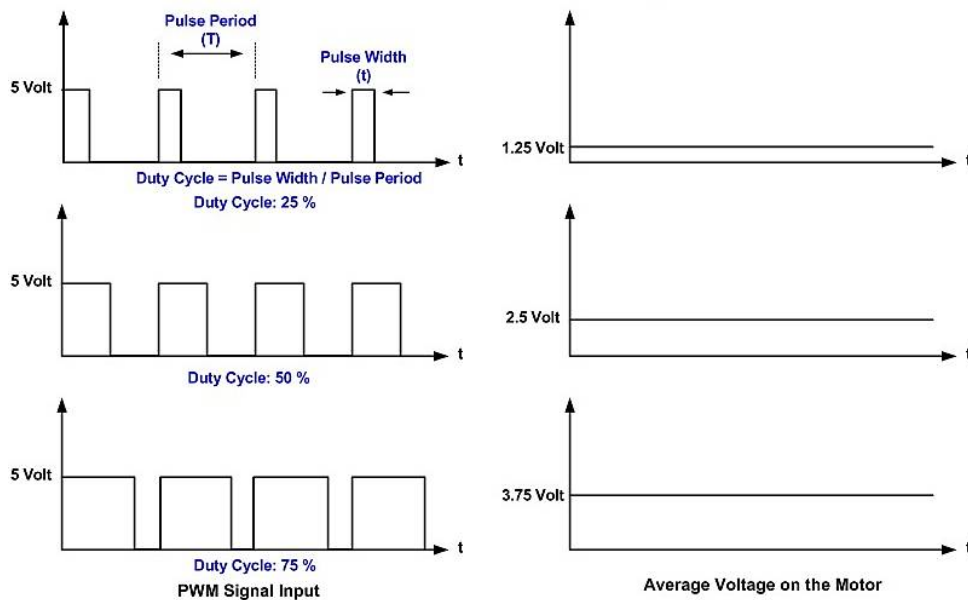

Figure 2. PWM Timing Diagram[13]

IV. BI-DIRECTIONAL CONTROL OF DC MOTOR

To change the direction of rotation of the DC motor, it is necessary to change the polarity of the voltage applied to the winding coil. The most common way is using “H bridge” configuration for changing easily DC motor direction. The shape of the circuit resembles an “H”, so it was named H bridge. Figure (3) illustrates an H bridge configuration. For ‘forward’ rotation Q1 and Q4 are switched on while Q2 and Q3 are off. For ‘reverse’ rotation Q2 and Q3 are on while Q1 and Q4 are off.

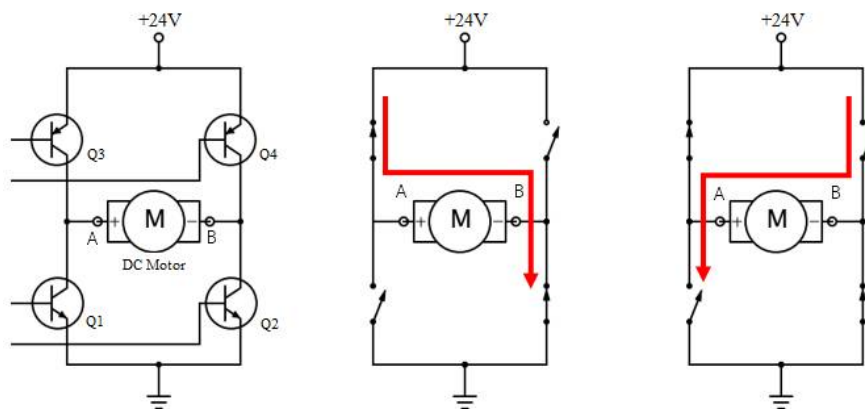

Figure 3. Bi-directional rotation using a H Bridge

International Journal of Innovative Research in Science, Engineering and Technology

(An ISO 3297: 2007 Certified Organization)

Vol. 6, Special Issue 10, May 2017

V. HARDWARE DESIGN AND IMPLEMENTATION

DC Motor control system was included DC Power Supply, dSPIC30f4011 Controller Card and LCD Screen, H Bridge DC Motor Driver Card and DC Motor. Controller Card and driver supplied with same power supply. Femsan brand DC Motor was used. DC Motor power was 300W and nominal rotation rate was 1500 rpm. System block diagram is given at Figure 3.

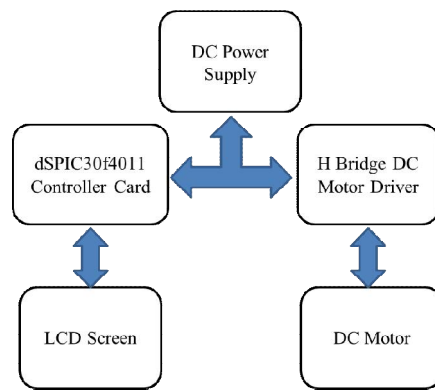

Figure 3. DC Motor Driver System Block Diagram

DC Motor driver circuit was evaluated as two main circuit. The first circuit was power part of driver and second part was H Bridge DC Motor control circuit. These two circuits are shown respectively at Figure 4 and Figure 5.

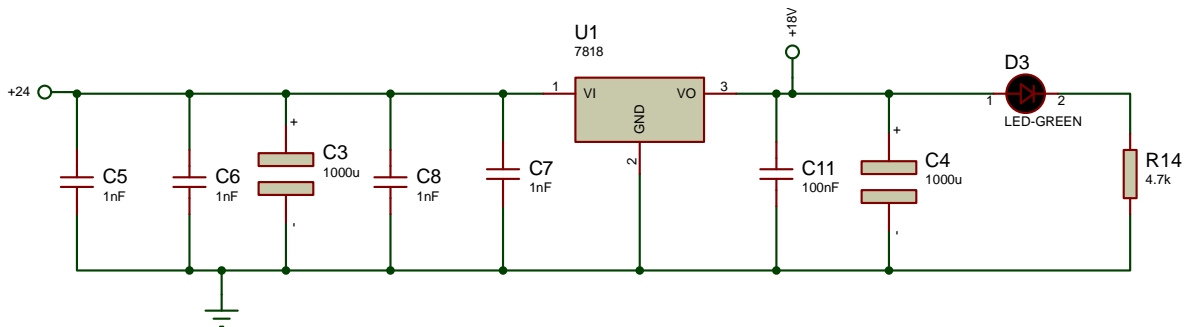

Figure 4. DC Motor Driver Power Circuit

International Journal of Innovative Research in Science, Engineering and Technology

(An ISO 3297: 2007 Certified Organization)

Vol. 6, Special Issue 10, May 2017

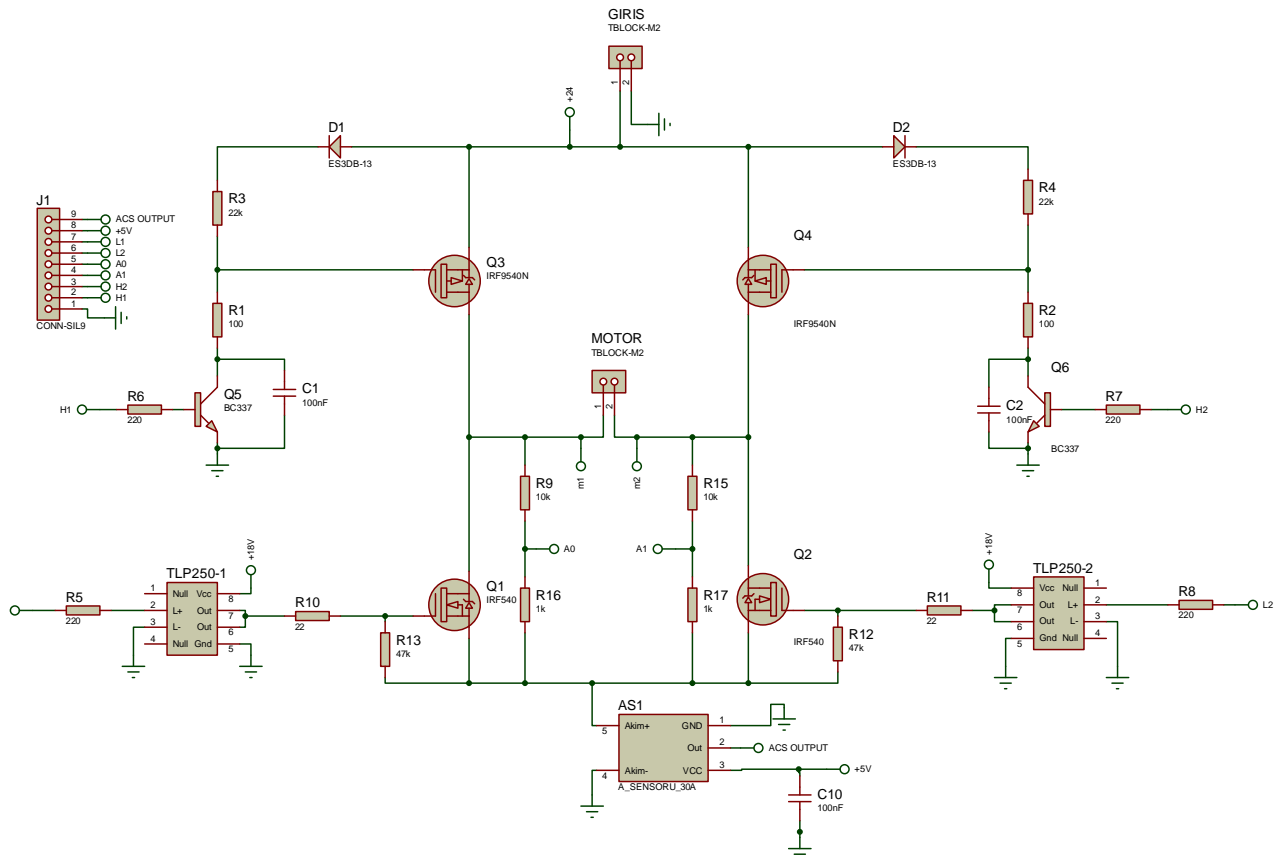

Figure 5. H-Bridge DC Motor Control Circuit

Designed H bridge circuit contains two NPN (Q1, Q2) and two PNP (Q3,Q4) type Power Mosfets. Direction of rotation and DC motor speed can be varied these mosfets. PWM signals are applied by means of mosfet driver TLP250 to NPN type Q1 and Q2 mosfets. According the duty rate of PWM signals DC motor speed can be increased or decreased. And steady +5V applied to PNP type Q3 and Q4 mosfets. While DC motor is rotated to right direction Q3 and Q2 mosfets have to be switched. If DC motor want to rotate left direction then Q4 and Q1 mosfets have to be switched. When H1 signal applied Q5 BC337 transistor is switched and +24V is grounded. So PNP type Q3 mosfet is switched. At the same time when PWM signal is applied to L2 NPN type Q2 is switched. So DC motor is turned right direction. The same operations are performed to when Q4 and Q1 switched. And DC motor current can be flow on ACS-712 current sensor. By means of this sensor DC motor current level can be determined. Such as rush current and short circuit situations are can be identified and blocked. Hence DC motor can be protected.

VLDC MOTOR DRIVER ALGORITHM

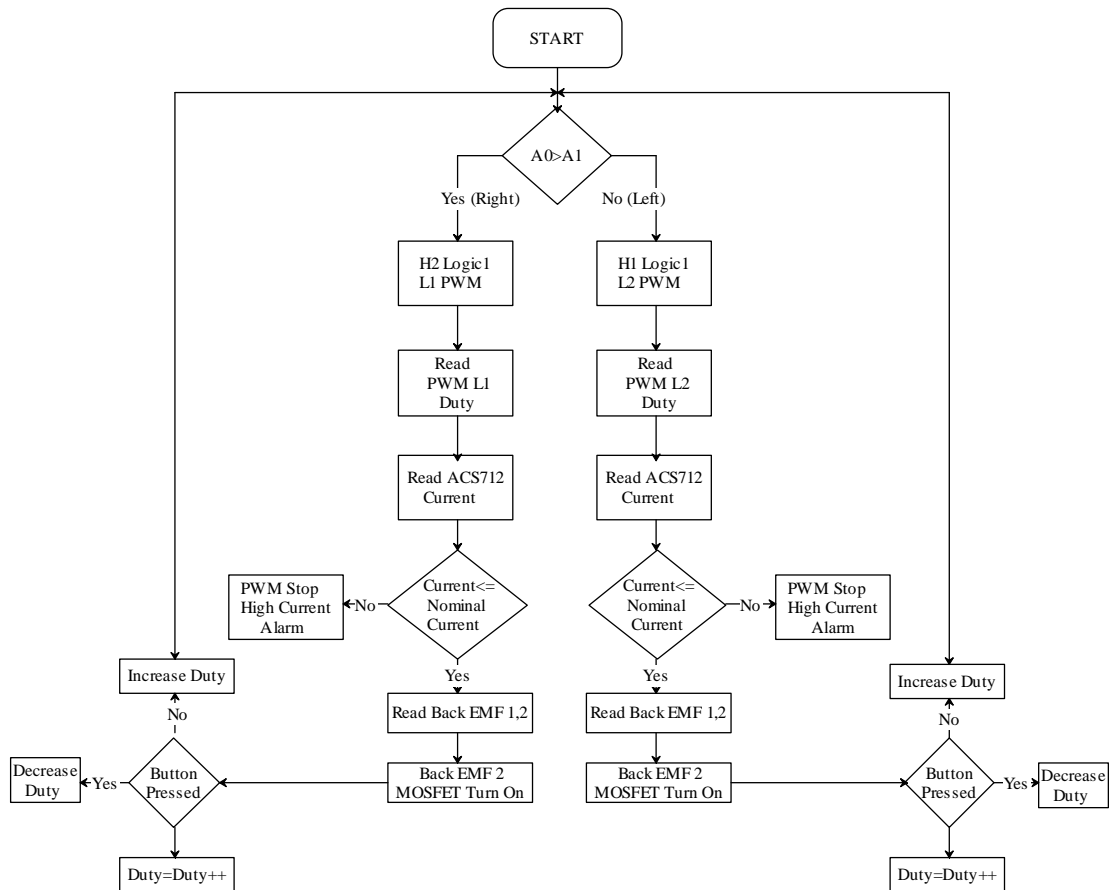

Figure 6. DC Motor Control Algorithm

Algorithm process same for the left or right rotating conditions. So it is enough for explaining algorithm logic order for right rotating operation. For the programming process dspic30f4011 microcontroller is used. This microcontroller is can gave three different PWM output to users. At first A0 and A1 are compared to determine the DC motor direction of rotation. A0 and A1 are analog voltage value of DC motor coil to determining back emf of the motor. When after the DC motor direction of rotation is determined according to direction Mosfets are switched. For right rotating direction H2 (logic 1) is applied to Q4 PNP Mosfet and PWM signal is applied to Q1 NPN Mosfet by means of L1 pin. L1 duty rate are determined. DC motor current value is read at current sensor. Read current sensor is compared to nominal current value. If this value is higher than nominal current value then PWM is stopped and system gives high current alarm. If it is lower than nominal current DC motor is driven. If reverse rotation button is pressed duty is decreased for soft transition. When DC motor is stopped then duty rate is increased for reverse rotation.

VII. EXPERIMENTAL RESULTS AND DISCUSSION

DC Motor driver in a H bridge configuration drove the 300W DC Motor. The experimental results for the DC Motor control system are shown as in Figures. (7-9). When the DC motor rotated to forward rotation Back Emf Voltage signal is seen at Figure 7(a). And NPN type Mosfet Gate switching signal can be seen at Figure 7(b). According to Figure 7(b)

International Journal of Innovative Research in Science, Engineering and Technology

(An ISO 3297: 2007 Certified Organization)

Vol. 6, Special Issue 10, May 2017

Mosfet was switched nearly 80 ns. When the motor is loaded with DC motor, the output voltage waveforms across the motor terminals in the forward direction and drawn current value has shown in Figure (8).

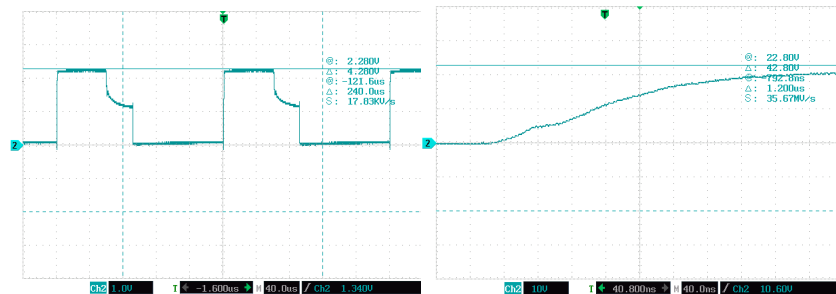

(a) Back Emf Signal

(b) NPN Mosfet Gate-Source Switching Signal

Figure 7. (a) DC Motor Back Emf Voltage, (b) NPN Mosfet Gate-Source Switching Signal

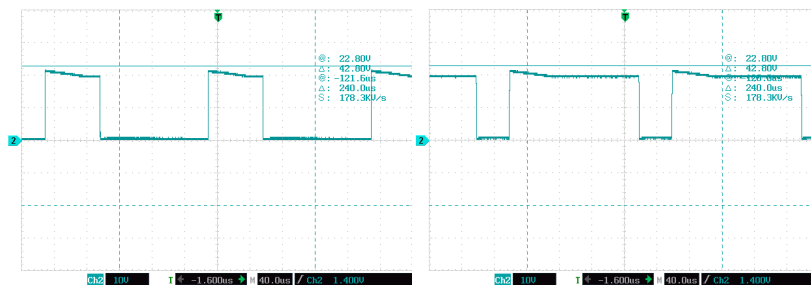

(a) 30% PWM, Forward, 0.5 A

(c) 75% PWM, Forward, 1.5 A

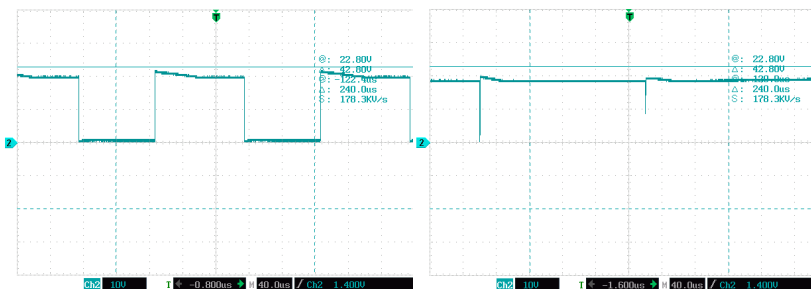

(b) 50% PWM, Forward, 1 A

(d) 100% PWM, Forward, 1.7 A

Figure 8. (a-d) The input voltage waveforms across the motor terminals with 30%, 50%, 75% and 100% PWM in the forward direction.

International Journal of Innovative Research in Science, Engineering and Technology

(An ISO 3297: 2007 Certified Organization)

Vol. 6, Special Issue 10, May 2017

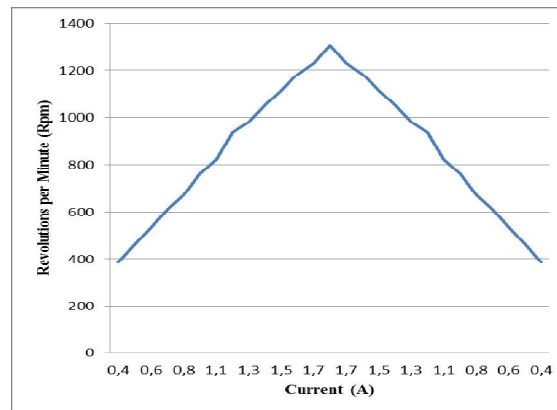

Figure 9. Motor bi-directional speed as a function of current.

By adjusting the potentiometer, the duty cycle (or input voltage) across the motor and thus its speed also varied. Figure (9) shows relationship between current and motor speed at bidirectional mode. Motor direction can only be changed when the button pressed and A0 or A1 is close to 0V. Reversing motor direction while the motor is turning could have damaging effects on the motor and drive circuit.

VIII. CONCLUSION

The designed PWM controlling DC motor driver circuit acts as a low-cost, efficient, and short circuit protected. Designed DC motor driver can controlled DC motor in both forward and reverse direction, from fully off to fully on. There is a common power supply used for DC motor driver and controller card. The PWM waveform is created using an dsPIC30f4011 microcontroller card. NPN and PNP type Mosfets were used for H bridge driver. PNP type Mosfets switched directly logic 1. So this technique reduced switching losses caused by excessive switching. Also the advantage of this topology is that two MOSFET drivers are used to DC motor speed control the operation. The proposed circuit can used for motor running at 12V or 24V and dawning up to about 10A. This designed DC motor driver can run a DC motor in clockwise or anti-clockwise direction. The motor is protected by a soft switching to prevent damage to the motor and the motor driver during the sudden change of rotation of the motor.

REFERENCES

- [1] Hughes, A. Electric Motors and Drives Fundamentals, Types and Applications, 3rd Edition, Austin Hughes, Published by Elsevier Ltd, 2006.
- [2] Vibhor Gupta, "Working and Analysis of the H – Bridge Motor Driver Circuit Designed for Wheeled Mobile Robots, Advanced Computer Control (ICACC), 2010 2nd International Conference, 27-29 March 2010, Shenyang, China
- [3] Payal P.Raval, Prof.C.R.mehta, "Modeling, Simulation and Implementation of Speed Control of DC Motor Using PIC 16F877A", International Journal of Emerging Technology and Advanced Engineering,, ISSN 2250-2459, Volume 2, Issue 3, March 2012
- [4] Y. S. E. Ali, S. B. M. Noor, S. M. Uashi and M. K Hassan, "Microcontroller Performance for DC Motor Speed Control System", National Power and Energy Conference (PECon) 2003 Proceedings, Bangi, Malaysia
- [5] Vibhor Gupta, "Working and Analysis of the H – Bridge Motor Driver Circuit Designed for Wheeled Mobile Robots, Advanced Computer Control (ICACC), 2010 2nd International Conference, 27-29 March 2010, Shenyang, China
- [6] Snehlata Sanjay Thakare1, Prof.Santosh Kompelli, "Design and implementation of dc motor speed control based on PIC microcontroller", International Journal Of Engineering And Computer Science ISSN:2319-7242 Volume - 3 Issue -9 September, 2014 Page No. 8075-8079
- [7] Jamal A. Mohammed, "PulseWidth Modulation for DC Motor Control Based on LM324", Eng. &Tech. Journal, Vol. 31,Part (A), No.10, 2013, 1882-1896
- [8] J. Nicolai and T. Castagnol, "A Flexible Microcontroller Based Chopper Driving a Permanent Magnet DC Motor," The European Power Electronics Application. 1993.
- [9] Mike Rylee, Low-Cost Bidirectional Brushed DC Motor Control Using the PIC16F684, Microchip Technology Inc., AN 893, 2003
- [10] Karthick, R. PC Based Speed Controlling of a DC Motor, Report, Circuit Ideas, Electronics for you, June 2004, pp. 67.
- [11] Moleykutty George, "Speed Control of Separately Excited DC Motor", American Journal of Applied Sciences 5 (3): 227-233, 2008.
- [12] Muhammad H. Rashid, "Power Electronics, Devices, and Applications," 3rd Edition, Pearson Prentice Hall, NJ, USA, 2004.
- [13] http://www.ermicro.com/blog/wp-content/uploads/2009/01/picpwm_03a.jpg 23.04.2017/17.31