

# Study of Multistoried RCC Flat Slab Structure, Under Seismic Effect

Renuka Ramteke<sup>1</sup>, Manish Chudare<sup>2</sup>, Amey Khedikar<sup>3</sup>

P.G. Student, Department of Structural Engineering, Tulairamji Gaikwad- Patil College of Engineering & Technology, Mohgaon ,Nagpur, India<sup>1</sup>

Assistant Professor, Department of Civil Engineering, Tulsiramji Gaikwa- Patil College of Engineering & Technology, Mohgaon,Nagpur,India<sup>2</sup>

Assistant Professor (HOD), Department of Civil Engineering, Tulsiramji Gaikwad- Patil College of Engineering & Technology, Mohgaon, Nagpur, India<sup>3</sup>

**ABSTRACT:** Flat-slab building structures possesses major advantages over traditional slab-beam-column structures because of the free design of space, shorter construction time, architectural –functional and economical aspects. Because of the absence of deep beams and shear walls, flat-slab structural system is significantly more flexible for lateral loads than traditional RC frame system and that make the system more vulnerable under seismic events. The critical moment in design of these systems is the slab-column connection, i.e., the shear force in the slab at the connection, which should retain its bearing capacity even at maximal displacements. The behavior of flat slab building during earthquake depends critically on ‘Building Configuration’. This fact has resulted in to ensure safety against earthquake forces of tall structures hence, there is need to determine seismic responses of such building for designing earthquake resistant structures. Response Spectrum analysis is one of the important techniques for structural seismic analysis. In the present work dynamic analysis of 15 models of multi-storied RCC Flat slab structure is carried out by response spectrum analysis.

**KEYWORDS:** Aspect Ratio, Slenderness Ratio, Response Spectrum Analysis, Drift , Displacement, Storey shear, SMRF R.C.C. flat slab structure.

## I. INTRODUCTION

A slab is a flat, two dimensional, planar structural element having thickness small compared to its other two dimensions. It provides a working flat surface or a covering shelter in buildings. It supports mainly transverse loads and transfers them to support primarily by bending element just like flat plate. Common practice of design and construction is to support the slabs by beams and support the beams by columns. This may be called as beam-slab construction. The beams reduce the available net clear ceiling height. Hence in warehouses, offices and public halls sometimes beams are avoided and slabs are directly supported by columns. These types of construction are aesthetically appealing also. These slabs which are directly supported by columns are called Flat Slabs.

### 1.1 Components of flat slab

**Panel:** Panel is defined as a part of a slab bounded on-each of its four sides by the centre-line of a Column or centre-lines of adjacent-spans.

**Drops:** The drops when provided shall be rectangular in plan, and have a length in each direction not less than one-third of the panel length in that direction.

**Column Strip:** Column strip means a design strip having a width of  $0.25L_2$ , but not greater than  $0.25L_1$ , on each side of the column centre-line, where  $L_1$  is the span in the direction moments are being determined, measured centre to centre of supports and  $L_2$  is the span transverse to  $L_1$ , measured centre to centre of supports.

# International Journal of Innovative Research in Science, Engineering and Technology

(An ISO 3297: 2007 Certified Organization)

Vol. 6, Special Issue 11, May 2017

**Middle Strip:** Middle strip means a design strip bounded on each of its opposite sides by the column strip.

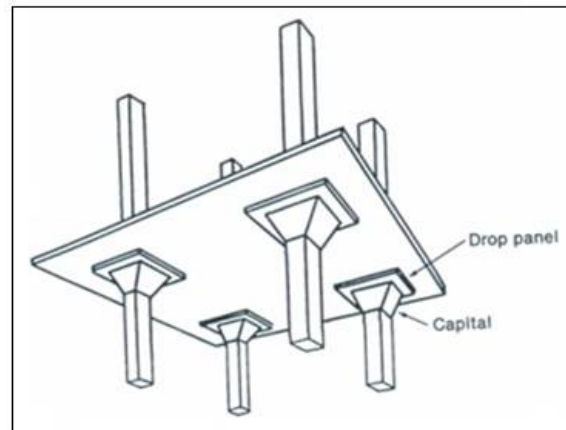

**Figure1.1 Showing Drop panel of flat slab**

## 1.2 Objectives

A detailed literature survey is carried out to define the objectives of the thesis. Based on the literature review presented later, the salient objectives of the present study have been identified as follows:

- To perform parametric study on behaviour of multi storied R.C.C. flat slab structure having same plan area but different plan aspect ratio (L/B) and slenderness ratio (H/B), under seismic condition.
- To perform analysis using Response Spectrum analysis.
- To study the behaviour of structure situated in seismic Zone III.
- To study effect on structure due to change in aspect ratio and change in slenderness ratio for structure, under seismic condition by observing results of analysis.
- 

## II. LITERATURE SURVEY

The literature survey is carried out in following major areas. These are:

- Research papers on response of buildings (regular or irregular configuration) under seismic loading,
- Importance of Indian seismic design codes and their introduction in brief.
- Discussion about Building configuration.
- Literature based on behavior of structure under Seismic condition.

The research paper and literatures collected on the various topics is listed below.

1. Rucha S. Banginwar and M. R. Vyawahare, (2012)
2. K S Sable (2012)
3. Arun Solomon (2013)
4. Mohit Sharma, SavitaMaru, (2014)

## III. METHODOLOGY AND DISCUSSION

### Modeling of Structural Element

Beam and columns are modeled as frame elements available in ETABS 13 structural analysis software, with central lines joined at nodes. Column slab joint are considered as rigid slab-column joints. The floor slabs are assumed to act as diaphragms, which ensure integral action of all the vertical lateral load resisting elements. The weight of the slab was distributed as shell load distribution. The columns ends are fixed. A response spectrum analysis applied for analysis of all the 25 models.

# International Journal of Innovative Research in Science, Engineering and Technology

(An ISO 3297: 2007 Certified Organization)

Vol. 6, Special Issue 11, May 2017

## Method Of Analysis

The Present Study Done for the Below Mentioned Analysis

1. Equivalent static analysis Method
2. Response spectrum method.

The steps undertaken in the present study to achieve the above-mentioned objectives areas follows:

- Carry out extensive literature review, to establish the objectives of the research work.
- Select an exhaustive set of R.C.C. flat slab building models with different number of storey (4 to 12 storeys), Aspect ratio (1to 5) in plan and constant plan area. (900 m<sup>2</sup>)
- Perform Response Spectrum Analysis for each of the 25 models.
- Analyse and compare the result obtained from response spectrum analysis of models which are base shear, storey drift, stiffness, natural time period, and frequency of earthquake. **Drop** from the slab to the column at it support.
- To resist this negative moment the area at the support needs to be increased, this is facilitated by providing column capital/heads flat slab.
- The drops when provided shall be rectangular in plan.
- To resist the punching shear which is predominant at the contact of slab and column Support, the drop dimension should not be less than one -third of panel length in that direction

### 1.Equivalent static analysis:

All design against seismic loads must consider the dynamic nature of the load. However, for simple regular structures, analysis by equivalent linear static methods is sufficient. This is permitted in most codes of practice for regular, low- to medium-rise buildings. This procedure does not require dynamic analysis, however, it account for the dynamics of building in an approximate manner. The static method is the simplest one-it requires less computational efforts and is based on formulated.

### 2. Response spectrum method

In order to perform the seismic analysis and design of a structure to be built at a particular location, the actual time history record is required. However, it is not possible to have such records at each and every location. Further, the seismic analysis of structures cannot be carried out simply based on the peak value of the ground acceleration as the response of the structure depend upon the frequency content of ground motion and its own dynamic properties. To overcome the above difficulties, earthquake response spectrum is the most popular tool in the seismic analysis of structures. There are computational advantages in using the response spectrum method of seismic analysis for prediction of displacements and member forces in structural systems. The method involves the calculation of only the maximum values of the displacements and member forces in each mode of vibration using smooth design spectra that are the average of several earthquake motions.

Response spectra are curves plotted between maximum response of SDOF system subjected to specified earthquake ground motion and its time period (or frequency). Response spectrum can be interpreted as the locus of maximum response of a SDOF system for given damping ratio. Response spectra thus helps in obtaining the peak structural responses under linear range, which can be used for obtaining lateral forces developed in structure due to earthquake thus facilitates in earthquake-resistant design of structures. Usually response of a SDOF system is determined by time domain or frequency domain analysis, and for a given time period of system, maximum response is picked. This process is continued for all range of possible time periods of SDOF system. Final plot with system time period on x-axis and response quantity on y-axis is the required response spectra pertaining to specified damping ratio and input ground motion. Same process is carried out with different damping ratios to obtain overall response spectra.

### Building Geometry

The study is based on three dimensional R.C.C. building with varying plan aspect ratio and slenderness ratio, but with a constant plan area. Different building geometries were taken for the study. These building geometries represent varying dimensions of regular configuration square and rectangular building.

## International Journal of Innovative Research in Science, Engineering and Technology

(An ISO 3297: 2007 Certified Organization)

Vol. 6, Special Issue 11, May 2017

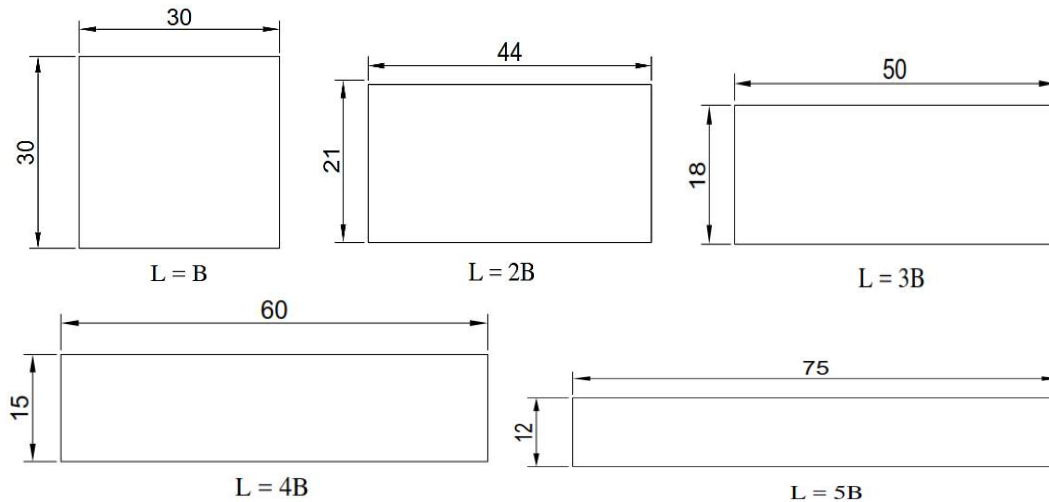

**Figure 3.1: Plan Aspect Ratio (Dimensions in Meter)**

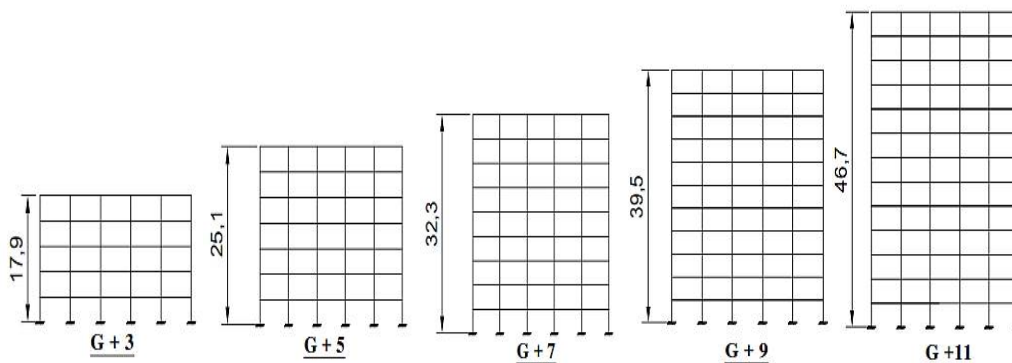

**Figure 3.2 : Storey Variation in Each Plan Aspect Ratio (Dimensions in Meter)**

- Design lateral force at each floor in each mode – The peak lateral force ( $Q_{ik}$ ) at floor  $i$  in Mode  $k$  is given by

$$Q_{ik} = A_{hk} \times \phi_{ik} \times P_{k \times} W_i$$

$$A_{hk} = \frac{Z I S_a}{2 R g}$$

Where,

$A_{hk}$  = Design horizontal spectrum value using natural period of vibration ( $T_k$ ) of mode  $k$ .

$Z$  = Zone factor for the maximum considered earthquake

$I$  = Importance factor depending upon the functional use of the structures

$R$  = Response Reduction factor

$S_a/g$  = Average response acceleration coefficient for rock or soil sites as given by response spectra and based on appropriate natural periods and damping of the structure.

- Storey shear forces in each mode – The peak shear force ( $V_{ik}$ ) acting in storey  $i$  in mode  $k$  is given by

$$V_{ik} = \sum_{j=i+1}^n Q_{ik}$$

- Storey shear force due to all modes considered – The peak storey shear force ( $V_i$ ) in storey  $i$  due to all modes considered is obtained by combining those due to each mode as per SRSS. If the building does not have closely spaced modes, than the peak response quantity due to all modes considered shall be obtained as per Square Root of Sum of Square method .

# International Journal of Innovative Research in Science, Engineering and Technology

(An ISO 3297: 2007 Certified Organization)

Vol. 6, Special Issue 11, May 2017

$$\lambda = \sqrt{\lambda_1^2 + \lambda_2^2 + \lambda_3^2 + \lambda_4^2 \dots}$$

Dynamic analysis may be performed either by time history method or by the response spectrum method. However in either method, the design base shear ( $V_B$ ) shall be compared with a base shear ( $\overline{V}_B$ ) calculated using a fundamental period ( $T_a$ ). When  $V_B$  is less than all the response quantities shall be multiplied by ( $V_B/\overline{V}_B$ ).

## IV. EXPERIMENTAL RESULTS

All the selected 25 building models with different plan aspect ratio and slenderness ratio are analyzed using commercial ETABS 13 software. This chapter presents the analysis result and relevant discussion based on analysis. According to objectives of present study, the results presented here are focused on storey shear, fundamental time period, lateral displacement and inter-storey drift. The details of selected building models and outline of analysis procedure followed in this study are in chapter 3

### Parameter For Comparative Study

Following parameters are considered for comparative study of software analysis results of all 25 models.

1. Base shear
2. Storey drift
3. Storey stiffness
4. Maximum storey displacement
5. Modal frequency and natural time period

Results obtained from software analysis of all 25 models were filtered and then arranged to compare it with respective values of other models. Results for individual model are shown first in tabular form then compared with models of same slenderness ratio and same aspect ratio in the form of graphical representation.

## V. CONCLUSION

Based on the work done in this dissertation following conclusions are drawn:

- Limiting plan aspect ratio is  $L/B = 5$  and slenderness ratio is 3.32.
- In earth quake prone area narrow and tall structure are not recommended, having aspect ratio more than  $L/B = 4$  and slenderness ratio 2.88 without infill elements.
- Structure with aspect ratio more than 3 has higher magnitude of design base shear along both X and Y direction though their seismic weight is lesser than structure with aspect ratio 3.
- Curtailment in column size reduces the seismic weight of structure, hence less seismic weight and less base shear.
- Buildings having square plan shape i.e. aspect ratio 1, is safest because:
- Lower and equal amount of base shear is acting along both X and Y direction.
- Fundamental time period for square plan structure is comparatively lesser than rectangular plan building. Hence it will perform well during earthquake with higher frequencies.
- Lateral deformation (i.e. lateral displacement and storey drift) for all the storey level is same along both X and Y direction.

## REFERENCES

- [1] K.S.Sable, V A Ghodechor, S B Kandekar, "Comparative Study of Seismic Behavior of Multi-storey Flat Slab and Conventional Reinforced Concrete Framed Structures", International Journal of Computer Technology and Electronics Engineering (IJCTEE) Volume 2, Issue 3, June 2012
- [2] Rucha.S.Banginwar, M.R.Vyawahare, P.O.Modani, "Effect of Plan Configurations on the Seismic Behaviour of the structure By Response Spectrum Method", International Journal of Engineering Research and Applications(IJERA),Vol2,May-June2012
- [3] Arun Solomon A, Hemalatha G, "Limitation of irregular structure for seismic response", International Journal Of Civil And Structural Engineering Volume 3, No 3, 2013

## International Journal of Innovative Research in Science, Engineering and Technology

*(An ISO 3297: 2007 Certified Organization)*

**Vol. 6, Special Issue 11, May 2017**

- [4] Mohit Sharma and SavitaMaru(2014), "Dynamic Analysis of Multistoried Regular Building" , Journal of Mechanical and Civil Engineering (IOSR-JMCE), Volume 11, Issue 1 Ver. II.
- [5] Mayuri D. Bhagwatand.P.S.Patil(2014), "Comparative study of performance of rccmultistory building for Koyna and Bhuj earthquakes", International Journal of Advanced Technology in Engineering and Science Volume No.02, Issue No. 07.
- [6] V.L. Shah and S.R. Karve, "Illustrated design of reinforced concrete buildings", Sixth edition, Structures publications, 36 Parvati, Pune-411009.
- [7] Paz. Mario. "Structural Dynamics" theory and Computation, CBS, Publishers and Distributors Dayaganj, New Delhi.
- [8] C.V.R.Murty,RupenGoswami,A.R.Vijayanarayanan and Vipul V. Mehta, "Some Concepts in Earthquake Behavior of Buildings", Gujarat State Disaster Management Authority Government of Gujarat.
- [9] BIS-1893, Criteria for Earthquake resistant design of structures-Part-1, General Provisions and Buildings, Bureau of Indian Standards, New Delhi -2002.
- [10] I.S-13920."Ductile detailing of reinforced structures subjected to seismic force" code of practice Bureau of Indian Standards, New Delhi -1993.