

Solar Water Heating System Using Innovative Flat Plate Collector and Storage Volume

M.V. Kulkarni¹, Dr. D. S Deshmukh², Dr S.P.Shekhawat³, Dr I.D.Patil⁴

Asst. Professor, Dept. of Mechanical Engineering, SSBT'S COET, Bambhori, Jalgaon, Maharashtra, India ¹

Principal, Vidarbha Institute of Technology, Nagpur, Maharashtra, India ²

H.O.D., Dept. of Mechanical Engineering, SSBT'S COET, Bambhori, Jalgaon, Maharashtra, India ³

H.O.D., Dept. of Biotechnology, SSBT'S COET, Bambhori, Jalgaon, Maharashtra, India ⁴

ABSTRACT: An Innovative design of solar water heater flat plate collector is developed and tested. The collector is made-up of rectangular aluminium having size 0.97 m X 1.81 m total surface area for heat conduction is 1.9845 m². The absorber is made of Aluminium box with one large surface exposed to sunlight having size 1.94 m x 1.1 m x 0.1 m, glass 4 mm thick toughened to cover the box large open surface, black paint for absorbing solar radiation and insulation layer. Maximum temperature of water obtained at outlet of collector is 73.3 °C. Also an innovative storage tank is investigated. The storage tank is made up of MS plate, 50 mm puff insulation, outer-cladding cover, inside coating with Fiber Reinforcement plastic and 60%-40% partition for hot and cold water. Due to this FRP coating thermal conductivity of tank material and night heat losses get reduced. In conventional hot water storage tank night temperature losses is found to be 9 °C while in modified FRP coating tank with partition night temperature losses is found to be 4 °C.

KEYWORDS: Fiber Reinforcement plastic (FRP),Collector, Hot water storage tank.

I. INTRODUCTION

A solar water heater consists of a collector to collect solar energy and an insulated storage tank to store hot water. The solar energy incident on the absorber panel coated with selected coating transfers the heat to the riser pipes underneath the absorber panel.

The water passing through the risers get heated up and is delivered the storage tank. The recirculation of the same water through absorber panel in the collector raises the temperature to 80 C (Maximum) in a good sunny day. The total system with solar collector, storage tank and pipelines is called solar hot water system.

Broadly, the solar water heating systems are of two categories. They are: closed loop system and open loop system. In the first one, heat exchangers are installed to protect the system from hard water obtained from borewells or from freezing temperatures in the cold regions. In the other type, either thermosyphon or forced circulation system, the water in the system is open to the atmosphere at one point or other. The thermosyphon systems are simple and relatively inexpensive. They are suitable for domestic and small institutional systems, provided the water is treated and potable in quality. The forced circulation systems employ electrical pumps to circulate the water through collectors and storage tanks.

The choice of system depends on heat requirement, weather conditions, heat transfer fluid quality, space availability, annual solar radiation, etc. The SHW systems are economical, pollution free and easy for operation in warm countries like ours. [1]

Based on the collector system, solar water heaters can be of two types.

✚ Flat Plate Collectors (FPC) based Solar Water Heaters

The solar radiation is absorbed by Flat Plate Collectors which consist of an insulated outer metallic box

covered on the top with glass sheet. Inside there are blackened metallic absorber (selectively coated) sheets with built in channels or riser tubes to carry water. The absorber absorbs the solar radiation and transfers the heat to the flowing water.

Solar water heating is now a mature technology. Wide spread utilization of solar water heaters can reduce a significant portion of the conventional energy being used for heating water in homes, factories and other commercial and institutional establishments. Internationally the market for solar water heaters has expanded significantly during the last decade. [2]

Developing efficient and inexpensive energy storage devices is as important a field as developing new sources of energy. Energy storage can reduce the time or rate mismatch between energy supply and energy demand, thereby playing a vital role in energy conservation. It improves the performance of energy systems by smoothening the output and thus increasing reliability. For example, storage would improve the performance of power generating plant by load leveling. The higher efficiency would lead to energy conservation and improve cost effectiveness.

It is clear that if solar energy is to become an important energy source, efficient, economical and reliable solar thermal energy storage devices and methods will have to be developed. Although, several methods have been proposed for storage as will be evident in this chapter yet they have not been around long enough to be fully evaluated.

The optimum size of solar thermal storage for space heating system depends on the type of application, and is a function of several parameters, such as type of material, storage temperature, storage heat losses, costs of the storage medium and container, type of heat exchanger and pumps, cost of auxiliary energy if any, climatic data such as solar radiation, ambient temperature, wind speed, sky conditions, etc. heating, collector type, its area and efficiency, fraction of the total heat load to be met by solar energy, thermo physical properties of the storage materials, etc. Some of the considerations which determine the selection of the method of storage and its design are as follows.

1. The temperature range over which the storage has to operate.
2. The capacity of the storage has a significant effect on the operation of the rest of the system, especially the collectors. A smaller storage unit operates at a higher mean temperature. This results in a reduced collector output as compared to a system having a larger storage unit.
3. Heat losses from the storage have to be kept to a minimum. Heat losses are of particular importance for 'long-term' storage.
4. Cost of the storage unit. This includes the initial cost of the storage medium, the containers and insulation, and the operating cost.

Other considerations include the suitability of materials used for the container, the means adopted for transferring the heat to and from the storage.

II. DESIGN & FABRICATION

For Collector

Aluminium Casing, GI Color Coated back cover, Copper riser, Top cover toughened glass etc. drawings and dimensions for standard system and modified solar water heating system are shown in Fig 1 and Fig 2. Also material requirement for project are listed in following table.

Water in riser copper = 1.92281 kg

Water inside header = 1.0331 kg

Water in Aluminium Collector = 17.55 kg

Material Requirement list

Material	Specification	Material	Specification
Aluminium Casing	1.2 mm thickness	Temperature sensor	PT 100
GI Color Coated back cover	1.1m*1.94m*0.0005m	Bolt Mild Steel	M10*40

Rock wool insulation	50 mm thickness	FiberReinforcement coating	inside coating
Header Tube	Ø0.025m, L = 1.05m	Absorber Unit aluminium	0.97m*1.810m*0.01m
Copper riser	Ø0.012m, L= 1.89m	Pipe Fitting	3/4 inch aqua pipe
Fitment flanges	For Installation	Ball Valve	3/4 inch
Top cover toughened glass	0.0004m thick	Tank	300 L
FPC stand	For Installation	Digital Indicator	12 Connection
MS sheet	2 mm thickness	Wire	10 Connection
MS pipe nipple	1 inch	MS wall Stand	For mounting Digital Indicator
Puff insulation	50 mm thicknesses	Mounting Stand	For installation
Outer cladding	Side cover		

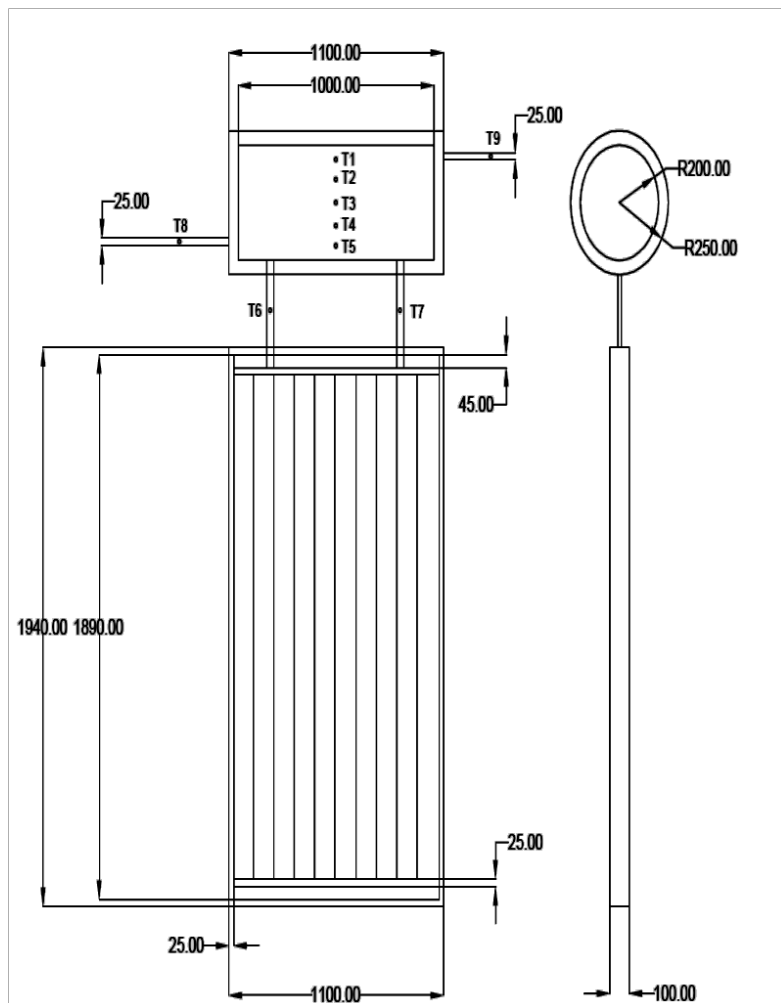

Fig 1 Standard Solar Water Heating System

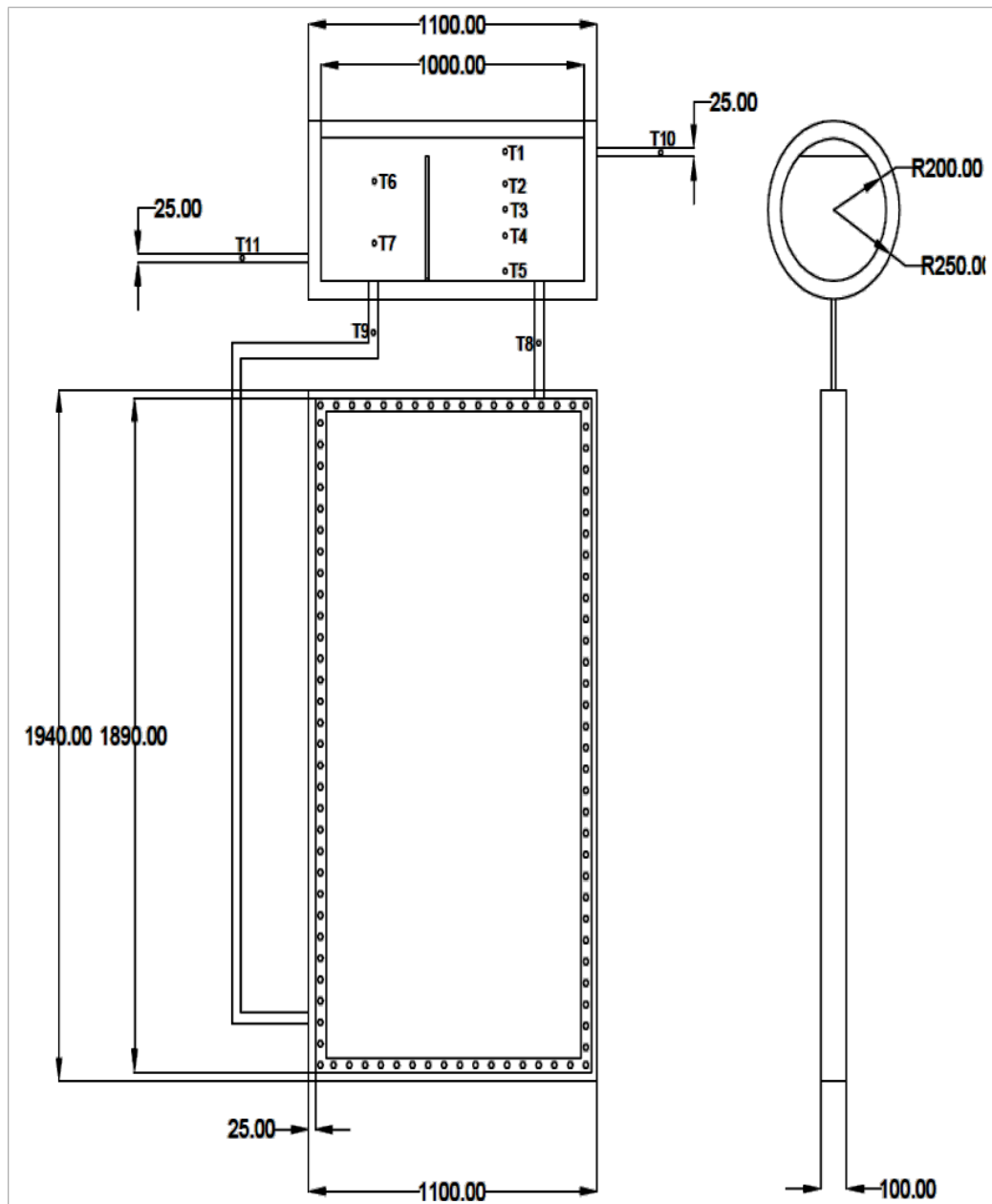

Fig 2 Modified Solar Water Heating System

III. EXPERIMENTAL WORK

Temperature sensors location:
Standard Solar Water Heating System

SENSOR	LOCATION	In ⁰ C
T ₁	Layer 1 (From Top)	71.2
T ₂	Layer 2	71.2
T ₃	Layer 3	71
T ₄	Layer 4	70.7
T ₅	Layer 5	69.8
T ₆	Collector Inlet	62.4
T ₇	Collector Outlet	62.7
T ₁₁	Tank Inlet	47.5
T ₁₂	Tank Outlet	71.1

Innovative Collector and Storage Tank

SENSOR	LOCATION	In ⁰ C
T ₁	Layer 1(From Top)(Hot Side)	73.3
T ₂	Layer 2 (Hot Side)	73.4
T ₃	Layer 3 (Hot Side)	73.1
T ₄	Layer 4 (Hot Side)	73.1
T ₅	Layer 5 (Hot Side)	70.5
T ₆	Layer 1 (Cold Side)	72.9
T ₇	Layer 2 (Cold Side)	70.2
T ₈	Collector Outlet	69
T ₉	Collector Inlet	69.7
T ₁₀	Tank Outlet	65
T ₁₁	Tank Inlet	47.5

IV. EXPERIMENTAL RESULTS

Result & Discussion:For Standard Collector System Efficiency and Maximum Temperature is found to be 26% and 71.2 °C. While for innovative collector it is found to be 29.77% and 73.3 °C. Also for Standard tank cooling rate is high in night while for innovative tank due to fiber reinforcement coating heat losses in night reduced so that cooling rate is low. It is found that for standard tank cooling temperature is reduced to about 9°C while in innovative tank cooling temperature is reduced to about 4°C.

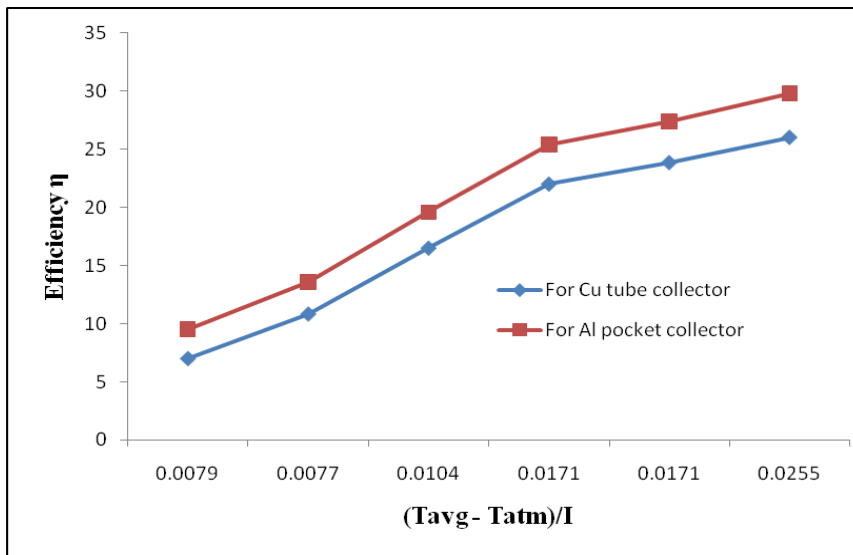

Fig 3 Hottel-Whiller Bliss curve

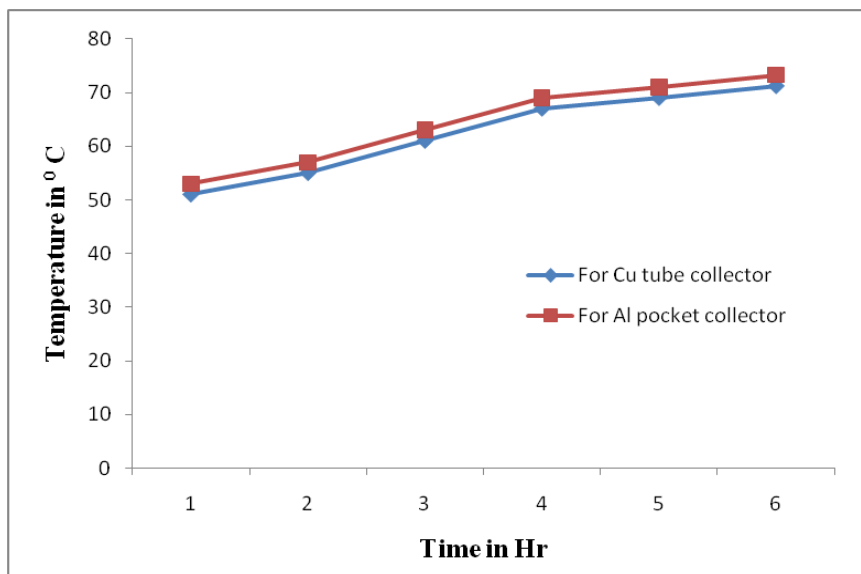

Fig 4 Water outlet temperature Vs Time

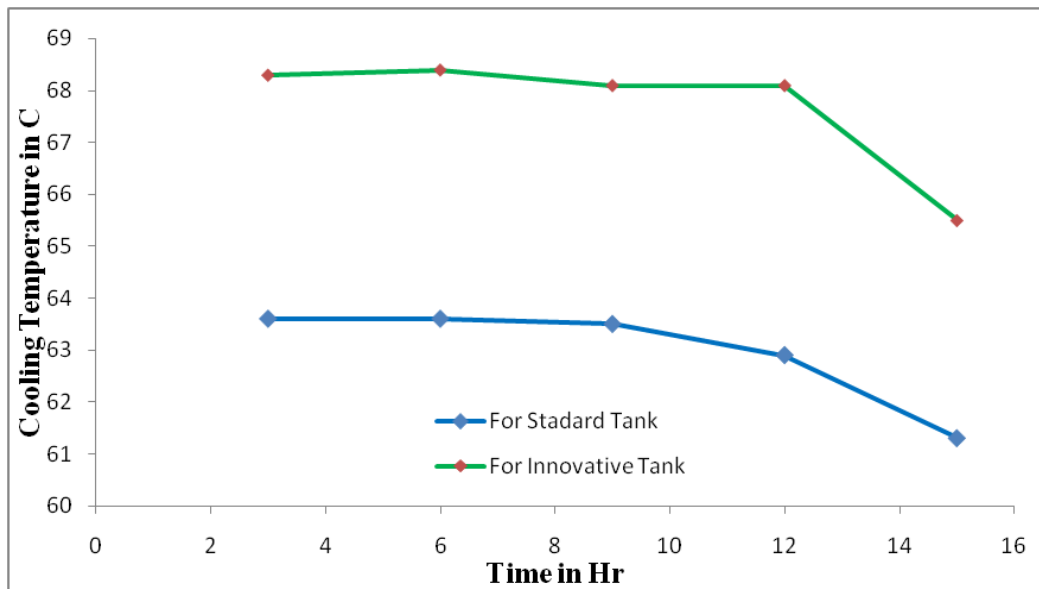

Fig 5 Night Cooling in Storage Tank

V. CONCLUSION

In this paper, a standard solar water heating system is compared with an innovative solar water heating system. In innovative system standard copper tube collector is replaced with aluminium pocket collector. Due to aluminium the copper tube cost is reduced. In innovative tank coated with fiber reinforcement plastic (FRP) due to this coating heat loss due to conduction and cooling rate is reduced. Also in innovative tank partition is given due partition mixing rate is reduced.

VI. FUTURE SCOPE

In this paper, while design innovative tank absorber black coated aluminium sheet is having thickness 1 mm. In future research scholar can vary this thickness. When thickness is reduced heat transfer rate through absorber is high but stiffness is reduced. While increase in thickness heat transfer rate through absorber is low but stiffness is increased. As decreasing thermal conductivity of storage tank material performance of storage tank increases. In this project innovative tank coated with fiber reinforcement plastic (FRP) due to this coating heat loss due to conduction and cooling rate is reduced. In future instead of inside coating research scholar can use low conductivity plastic as storage tank material.



REFERENCES

- [1] G.N.Kulkarni Optimization of solar water heating systems through water replenishment Energy Conversion and Management 50 (2009) pg 837–846
- [2] P. Armstrong*, D. Ager, I. Thompson, M. McCulloch Improving the energy storage capability of hot water tanks through wall material specification Energy 78 (2014) 128-140
- [3] Kulkarni G.N. Kedare SB, Bandyopadhyay S. Determination of design space and optimization of solar water heating systems. Solar Energy 2007;81(8):958–68.
- [4] Jianhua Fan, Simon Furbo, Hongqiang Yue Development of a hot water tank simulation program with improved prediction of thermal stratification in the tank Energy Procedia 70 (2015) 193 – 202.
- [5] Kulkarni G.N. Kedare SB, Bandyopadhyay S. Design of solar thermal systems utilizing pressurized hot water Solar Energy 82 (2008) 686–699
- [6] Ryan M. Dickinson*, Cynthia A. Cruickshank, Stephen J. Harrison The effect of discharge configurations on the thermal behaviour of a multi-tank storage system Energy Procedia 30 (2012) 215 – 224
- [7] ShuhongLi*, Yongxin Zhang, Kai Zhang, Xianliang Li, Yang Li, Xiaosong Zhang Study on performance of storage tanks in solar water heater system in charge and discharge progress Energy Procedia 48 (2014) 384 – 393
- [8] Wenfeng Gao, Tao Liu, Wenxian Lin, Chuanxu Luo Numerical Study on Mixing Characteristics of hot Water inside the Storage Tank of a Solar System with Different Inlet Velocities of the Supply Cold Water Procedia Environmental Sciences 11 (2011) 1153 – 1163
- [9] Yoram L. Shabtay, John R.H. Black Compact hot water storage systems combining copper tube with high conductivity graphite and phase change materials SHC 2013, International Conference on Solar Heating and Cooling for Buildings and Industry September 23-25, 2013, Freiburg, Germany
- [10] Sharma A, Tyagi VV, Chen CR, Buddhi D, Review of Thermal Energy Storage with Phase Change Materials and Applications, Renewable and Sustainable Energy Reviews 2009; 13:318 – 345.
- [11] H. P. Garg, J Prakash *Solar Energy* Fundamental and Application First Revised Edition, Tata McGraw-Hill.
- [12] S. P. Sukhatme, J. K. Nayak *Solar Energy* Principle of Thermal Collection and Storage third edition The McGraw-Hill Companies.
- [13] Dr. D S Deshmukh, Mr. M.V.Raolani and Mr. M.V. Kulkarni, “Design Considerations for Solar Water Heating System Techniques: A Critical Review” organized by ShramSadhana Bombay Trust’s College of Engineering & Technology, Bambhori, Jalgaon, International Conference on Advances in Energy Technology on March 29, 2013.
- [14] Mahesh V. Kulkarni, Dr.Dheeraj S. Deshmukh and Dipak C. Talele, “Solar Water Heater Collector Testing Methodology” at International Conference on Sustainable Development 2014, organized by S.S.B.T.’s, College of Engineering & Technology, Bambhori, Jalgaon, on dated 25th-26th February 2014
- [15] Mr. M.V. Kulkarni, and Dr. D.S. Deshmukh, “Improving Efficiency of Solar Water Heater Using Phase Change Materials” in Pratibha: International Journal of Science, Spirituality, Business and Technology (IJSSBT), ISSN (Print) 2277-7261 and ISSN (on-line):2278-3857, Page No. 39- 44, Volume 3, No.1, Dec., 2014.
- [16] M.V. Kulkarni, Dr. D.S. Deshmukh published a research paper entitled - Design of Experiment for Solar Water Heater Performance Analysis in Pratibha: International Journal of Science, Spirituality, Business and Technology (IJSSBT), ISSN (Print) 2277-7261 and ISSN (on-line):2278-3857, Page No. 55- 60, Volume 3, No.2, June
- [16] M.V. Kulkarni, Dr. D.S. Deshmukh published a research paper entitled - Investigation of Storage Tank Performance Using Phase Change Material in a Solar Water Heating System in Pratibha: International Journal of Science, Spirituality, Business and Technology (IJSSBT), ISSN (Print) 2277-7261 and ISSN (on-line):2278-3857, Page No. 24-29, Volume 4, No.1, November, 2015.