

Design and Failure Analysis of Flange Coupling with Uniform Strengthen Bolts

Kondru Nagendra Babu¹, Syed Chandpasha², Khatroth.Dattaterya³, Kachve.Jathin⁴

Assistant Professor, Department of Mechanical Engineering, VNR Vignana Jyothi Institute of Engineering and
Technology, Bachupally, Hyderabad, India.¹,

B.Tech Students, Department of Mechanical Engineering, VNR Vignana Jyothi Institute of Engineering and
Technology, Bachupally, Hyderabad, India.^{2,3,4}.

ABSTRACT: A Coupling is a device used to make permanent or semi-permanent joint for two rotating shafts to each other. It is used to join two pieces of rotating equipment while permitting some degree of misalignment and for the purpose of transmitting power and torque. Rigid flange couplings are designed for heavy loads or industrial equipment's. The present study of this paper is to reduce the stress that acting on the bolts by making it uniform strengthen. The stress in the threaded part of the bolt will be higher than that in the shank. Hence a greater portion of the will be absorbed at the region of the threaded part which may fracture the threaded portion because of its small length. An axial hole is drilled at the centre of the bolt through the head as far as thread portion such that the stress in the bolt is uniformly distributed along the length of the bolt.

KEYWORDS: CATIA, ANSYS Workbench 15.0, Rigid Flange Coupling, Finite Element Method (FEM).

I. INTRODUCTION

Flange couplings are widely used for heavy power transmission at low speeds. A flange coupling usually applies to a coupling having two separate cast iron flanges. The flange consists of two cast iron hubs keyed to the two shafts. The hubs extended into flanges whose faces are brought and held together by a series of bolts, arranged concentrically about the shafts so that their axes are parallel to the shaft axes. To ensure correct alignment, one of the hub has a circular projection which fits into a corresponding depression in the other hub. The bolts transmit torque from one flange to the other flange, and then to shaft. Design of flange coupling includes the design of hubs, flanges, key and bolts [4]. The strength of the members in flange coupling are should be good enough for applied load [7]. Replacing the bolts, maintenance cost increases [1] so as to decrease it and to increase strength of bolt we introduced uniform strengthened bolts.

II. MATERIAL AND PROPERTIES

Rigid flanges are usually manufactured by casting process technique. The commonly used material for flange coupling grey cast iron (ferrous metal carbon % between 2.5 to 4) which is characterized by graphite flakes microstructure to have a grey appearance because it has a good damping capacity compare to other ferrous metals. The composition of grey cast iron are 2.5-4% carbon, 1-3% silicon and the rest is iron by weight proportion. It has less tensile strength and good shock resistance as compared to its compressive strength. It's mechanical Properties are controlled by the size of the graphite flakes which it has good wear resistance and damping capacity. It also has less solidification shrinkage than other cast iron that does not easily form graphite microstructure while grain growth during solidification. The silicon promotes good corrosion resistance and increase fluidity while casting.

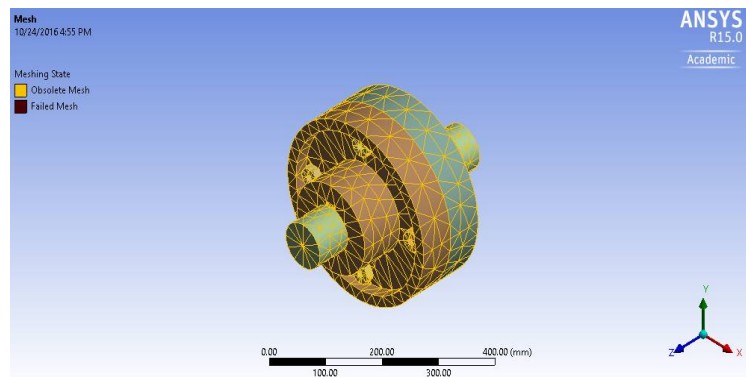

Table.1. Material Properties

Items Name	Material
Flange	Grey Cast Iron
Shaft	Mild Steel
Key, Nuts and Bolts	Mild Steel

II. OBJECTIVE

The main objective is to reduce the crushing stress that acting in the bolts by making it uniform strengthen. The stress in the threaded part of the bolt will be higher than that in the shank. Hence a greater portion of the will be absorbed at the region of the threaded part which may fracture the threaded portion because of its small length.

III. DESIGN AND CALCULATION

Input Parameters

Material: Mild Steel for shaft, key, Nut and Hexagonal bolt

Power transmit: 80 kW at running at 200 rpm

Allowable shear stress in shaft τ : 45 N/mm²

Allowable shear stress for key material τ : 45 N/mm²

Crushing stress for bolt and key: 160 N/mm²

Shear stress for bolt material τ : 30 N/mm²

Shear stress for cast iron τ : 8 N/mm²

CALCULATIONS

I) Design torque T_d = Torque X service factor

Assume service factor as 1.35 then design torque

$$\text{Torque} = \frac{\text{power in watts} \times 60}{2\pi \times \text{speed in rpm}}$$

$$= \frac{80 \times 1000 \times 60}{2\pi \times 200} = 3819.71 \text{ N-m}$$

$$\text{Design torque} = 3819.71 \times 1.35$$

International Journal of Innovative Research in Science, Engineering and Technology

(An ISO 3297: 2007 Certified Organization)

Website: www.ijirset.com

Vol. 6, Issue 1, January 2017

$$= 5165.6085 \text{ N-m}$$

$$\text{Torque transmitted by a shaft } T = \frac{\pi \times d^3 \times \tau}{16}$$

$$d = \sqrt[3]{\frac{5165.6085 \times 16 \times 10^3}{45 \times \pi}} = 83.616 \text{ mm} \approx 85 \text{ mm}$$

II) DIMENSIONS OF HUB FOR SHAFT

A) Hub diameter $D = 2 \times d = 2 \times 85 = 170 \text{ mm}$

B) Length of hub $= 1.5 \times d = 1.5 \times 85 = 127.5 \text{ mm} \approx 130 \text{ mm}$

C) Key dimensions $b = 22 \text{ mm}$; $h = 14 \text{ mm}$ (from reference table)

D) Flange thickness $t_f = 0.5d = 0.5 \times 85 = 42.5 \text{ mm}$

E) Design for hub $\tau_{\text{hub}} = \frac{16 \times \text{Torque} \times D}{\pi(D^4 - d^4)} = \frac{16 \times 5165.6085 \times 10^3 \times 170}{\pi(170^4 - 85^4)} = 5.711 \text{ N/mm}^2 \leq 8 \text{ N/mm}^2$

Hence the design is safe. Since the induced shear stress for the hub material cast iron is less than permissible value.

III) DESIGN FOR KEY

Width of key = 22mm; thickness of key = 14mm; length of key = 130mm

$$\text{Induced shear stress in the key material } \tau_{\text{key}} = \frac{2T}{lwd} = \frac{2 \times 5165.6085 \times 10^3}{130 \times 22 \times 85} = 42.49 \text{ N/mm}^2 \leq 45 \text{ N/mm}^2$$

$$\text{Crushing stress in the key material } \sigma_{\text{key}} = \frac{4T}{ltd} = \frac{4 \times 5165.6085 \times 10^3}{130 \times 14 \times 85} = 133.57 \text{ N/mm}^2 \leq 160 \text{ N/mm}^2$$

IV) Design for Bolts (4 bolts for shaft diameter from 40 to 100mm)

$$\text{Force on the bolts} = \frac{\text{Torque}}{\frac{D_s}{2}} = \frac{5165.6085 \times 10^3}{1.5 \times 85} = 40514.50 \text{ N}$$

$$\text{Force on each bolt } F_{\text{tb}} = 10128.62 \text{ N}$$

Shear failure for bolts

$$F_{\text{tb}} = \frac{\pi}{4} \times d_b^2 \times \tau_{\text{bolt}}$$

$$d_b = \sqrt{\frac{10128.62 \times 4}{\pi \times 30}} = 20.733 \approx M24$$

$$\text{Crushing stress } \sigma_c = \frac{F_{\text{tb}}}{t_f \times d} = \frac{10128.62}{42.5 \times 24} = 10.832 \text{ N/mm}^2 \leq 160 \text{ N/mm}^2$$

V) FAILURE OF FLANGE BY SHEARING FROM HUB

$$T_d = \pi D t_f \tau \times \frac{D}{2}$$

$$5165.60 \times 10^3 = \pi \times 170 \times 42.5 \times \tau \times \frac{170}{2}$$

$$\tau = 2.667 \text{ N/mm}^2 \leq 8 \text{ N/mm}^2$$

OTHER PROPORTIONS OF FLANGE

$$D_o = 4d = 4 \times 85 = 340 \text{ mm}$$

$$t_p = 0.25d = 0.25 \times 85 = 21.25 \text{ mm} \approx 22 \text{ mm}$$
 Where t_p Thickness of protective circumferential flange

DIAMETER OF AXIAL HOLE IN BOLT

$$d_h = \sqrt{d^2 - d_c^2} = \sqrt{24^2 - 20.320^2} = 12.770 \text{ mm} \approx 13 \text{ mm}$$

Part specification	Dimensions in mm.
Hub diameter (d_h)	170
Hub length (l_h)	130
Bolt circle diameter (D)	24
Flange thickness (t)	42.5
Web thickness	22
Outside diameter flange (D_o)	340

International Journal of Innovative Research in Science, Engineering and Technology

(An ISO 3297: 2007 Certified Organization)

Website: www.ijirset.com

Vol. 6, Issue 1, January 2017

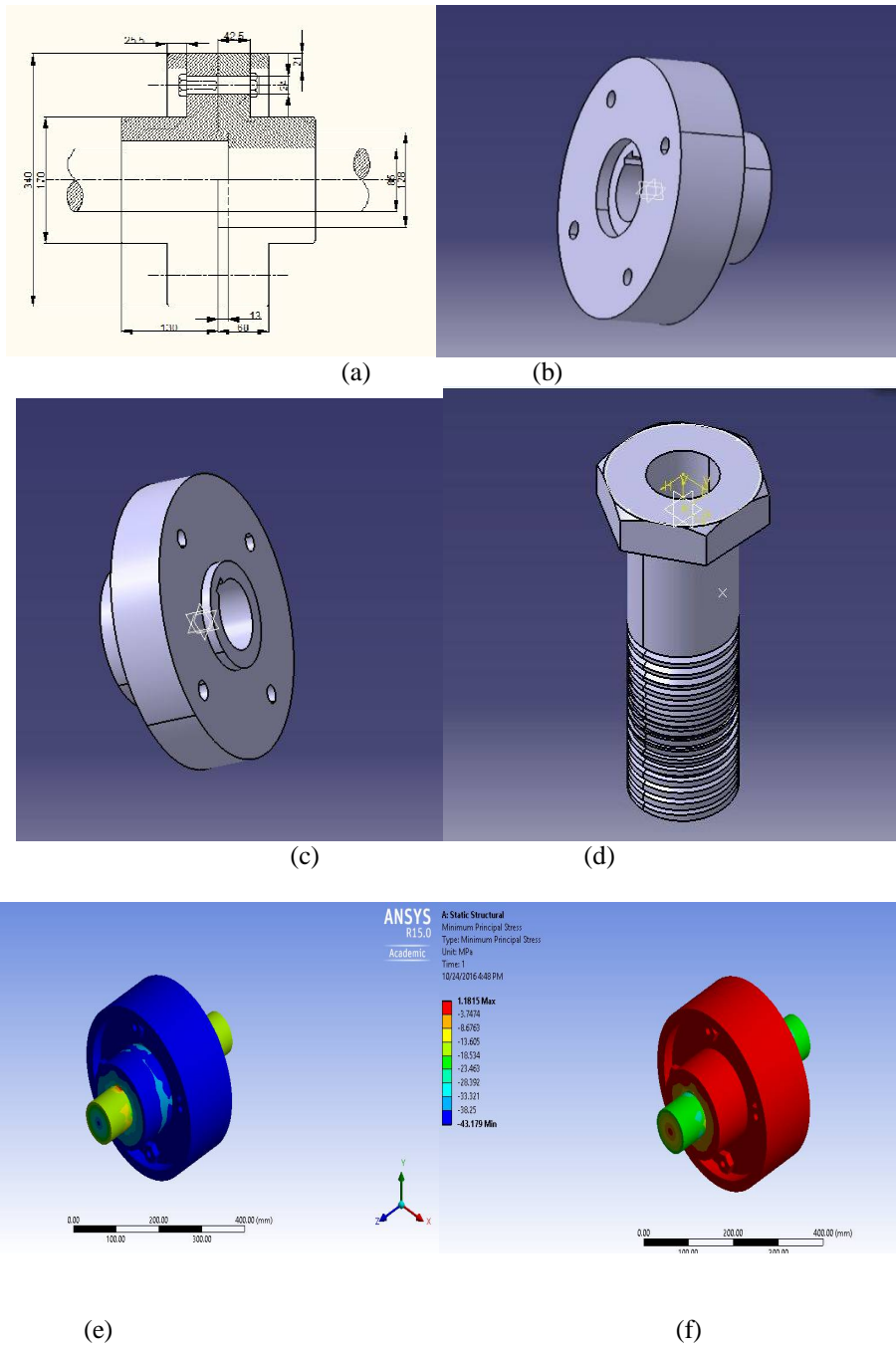
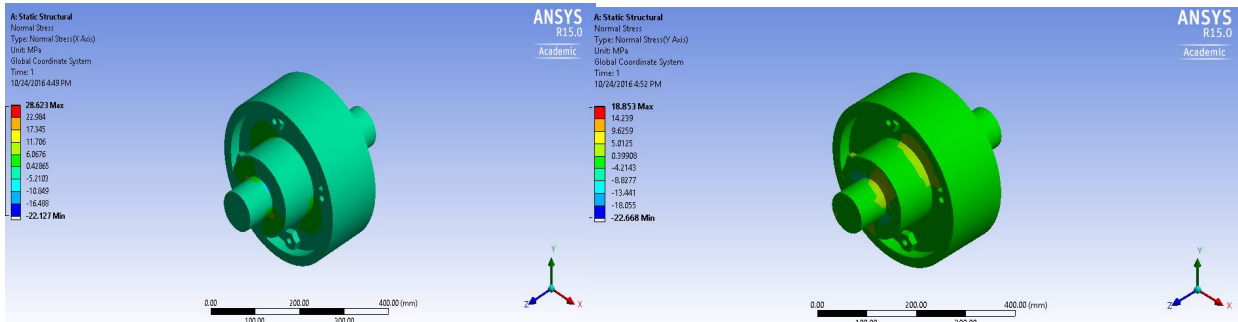
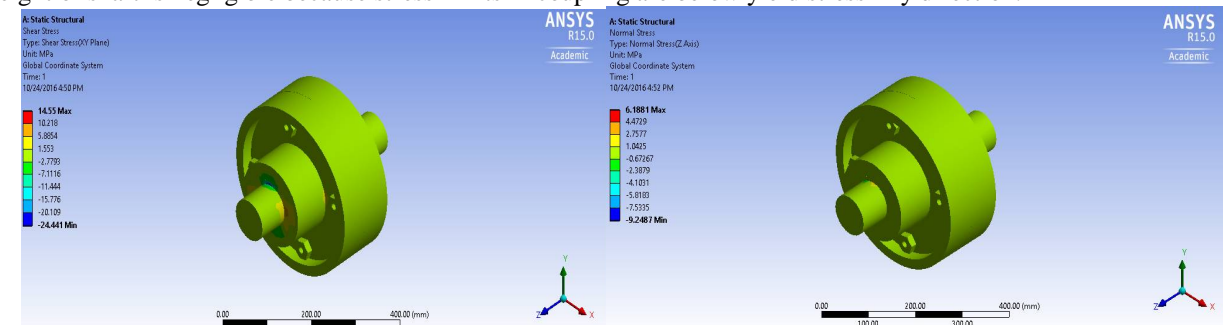

FIG 1 (a) Autocad 2-D (b) LHS View (c) RHS View (d) Hexagonal Bolt (e).maximum principal stress (f).minimum principal stress



(a) The normal stress in X axis varies from -5.2103 to 6.0676 Mpa. And hence the shearing of bolts doesn't take place in X- direction.

(b) The normal stress in Y axis varies from -4.02143 to 5.0125 Mpa. here deflection caused in coupling due to weight of shaft is negligible because stress limits in coupling are below yield stress in y direction.



(c) Though the shear load and radial load acting in XY plane, the total loads acting are in permissible limit.

(d) The thrust load acting on Z axis there is no relative movement between shaft and hub.

FIG 3. (a).Normal stress X-Axis :

(b) Normal stress Y-Axis

(c) Normal stress Z-Axis

(d) Shear stress XY Plane

IV. ANALYSIS

There are several methods for analysing. In this project we are using Ansys software for analysing. Ansys is a leading finite element analysis software developed by Ansys inc. it is widely used worldwide graphical user interface package. In a linear static we determine the stresses, displacements, strain. Static analysis deals with computation of displacement and stress due to static loads refers to loading but doesn't cause inertial or damping effects. The material used for coupling is grey cast iron, the Poisson's Ratio of material is 0.28 and the Young's Modulus is $1.1 \times 10^{11} \text{ N/mm}^2$.

International Journal of Innovative Research in Science, Engineering and Technology

(An ISO 3297: 2007 Certified Organization)

Website: www.ijirset.com

Vol. 6, Issue 1, January 2017

V. RESULTS

State	Fully Defined	
Scope		
Scoping Method	Geometry Selection	
Geometry	2 Faces	1 Face
Definition		
Type	Fixed Support	Moment
Suppressed	No	
Define By	Components	
Coordinate System	Global Coordinate System	
X Component	0. N·mm (ramped)	
Y Component	0. N·mm (ramped)	
Z Component	5.1656e+006 N·mm (ramped)	
Behaviour	Deformable	
Advanced		
Pinball Region	All	

Table: 2 Results comparison between Analytical and Theoretical values

Parameters	Theoretical	Analytical
Crushing stress of bolt	160 N/mm ²	110.26 N/mm ²
Shear stress of bolt	30 N/mm ²	14.55 N/mm ²
Crushing stress of key	160 N/mm ²	28.623 N/mm ²
Shear stress of key	45 N/mm ²	34.119 N/mm ²
Shear stress of hub flange	8N/mm ²	9.61 N/mm ²

MATERIAL DATATABLE-3

Mild steel> Isotropic Elasticity

Temperature C	Young's Modulus MPa	Poisson's Ratio	Bulk Modulus MPa	Shear Modulus MPa
	2.1e+005	0.3	1.75e+005	80769

TABLE-4

Grey cast iron> Isotropic Elasticity

Temperature C	Young's Modulus MPa	Poisson's Ratio	Bulk Modulus MPa	Shear Modulus MPa
	1.1e+005	0.28	83333	42969

VI.CONCLUSION

The result obtained from the analysis of the bolts and keys of a rigid-flange coupling using ANSYS workbench is better than that of calculation using analytical method. It was found that the crushing stress for bolts and shear stress in bolts, keys obtained from the Ansys software is slightly less than the crushing and shear stress obtained in the theoretical calculation. Hence the results obtained from Ansys matches theoretical calculations so the design is safe. From this comparison we can conclude that the design of coupling done using CATIA is more suitable and safe.

REFERENCES

- [1] Kondru Nagendra Babu "Failure analysis of flange coupling with two different materials". (IJERT), Vol. 4 Issue 04, April-2015, ISSN: 2278-0181
- [2] Coupling Wikipedia, <https://en.wikipedia.org/wiki/Coupling>



ISSN(Online) : 2319-8753
ISSN (Print) : 2347-6710

International Journal of Innovative Research in Science, Engineering and Technology

(An ISO 3297: 2007 Certified Organization)

Website: www.ijirset.com

Vol. 6, Issue 1, January 2017

- [3] V.B. Bhandari, Design of Machine Elements, ISBN: 0-07-0681791-1 (978-0-07-068179-8)
- [4] Machine design by R.S.Khurmi, ISBN:978-81-219-2537-2
- [5] mild steel: <http://saajsteel.com/>
- [6] Cast iron: https://en.wikipedia.org/wiki/Cast_iron,
- [7] V. G. Vijaya “Analysis of rigid flange coupling”. (IJIRSET), ISO 3297: 2007, Vol. 2, Issue 12, December 2013, ISSN: 2319-8753
- [8] Rabindra Nath Barman Design and Stress-Analysis of a Rigid Flange Coupling using FEM (IJIRSET),ISO3297:2007 Vol. 4, Issue 10 October 2015
- [9] V.B. Bhandari, Machine Design Data Book, ISBN: 93-5134-284-0 (978-93-5134-284-7) Chapter 9.6 Coupling.
- [10] PSG College of Technology, “DESIGN DATA BOOK OF ENGINEERS” April 2010
- [11] Design and stress-Analysis of a Rigid Flange Coupling using FEM by Saurav Rajgadia Vol. 4, Issue 10, October 2015 ISSN(Online) :2319-8753.