

International Journal of Innovative Research in Science, Engineering and Technology

(An ISO 3297: 2007 Certified Organization)

Website: www.ijirset.com

Vol. 6, Issue 6, June 2017

IoT Platform Based Intelligent Medicinebox

Ninu P.J.¹, Varun Kesav M.N.²

M.Tech Student, Department of ECE, Vidya Academy of Science and Technology, Thrissur, Kerala, India¹

Assistant Professor, Department of ECE, Vidya Academy of Science and Technology, Thrissur, Kerala, India²

ABSTRACT: Most of the elders have multiple chronic diseases, and they use medicines to stabilize their health conditions. Pharmacists Association advised that the family should be more concerned on medication safety of the elders. Most patients with chronic diseases need to take medications over a lengthy period of time in order to stabilize their health conditions. Confirming that the patients consume the right medication at the proper time becomes crucial. An IoT-based intelligent home-based health care platform, which perfectly connects smart sensors attached to the human body for biological monitoring and intelligent medical packaging for daily medication management. The system can give timely reminders to patients about their medication, and exactly control the type and amount of prescribed medicines, thus avoiding medication misuse and abuse. When a patient consults a doctor, his/her details including medicine prescription will be uploaded to the webserver. From the remote physician's perspective, it is very convenient to make or update a prescription for a particular patient.

KEYWORDS: Health monitoring, Intelligent medicine box, IoT module

I. INTRODUCTION

Medication compliance (adherence) describes the degree to which a patient correctly follows medical advice. The definition by Cramer et al.: Adherence "refers to the act of conforming to the recommendations made by the provider with respect to timing, dosage, and frequency of medication taking." [2]. According to the study of Times of India, over 20% of the India's population suffers from at least one of the non-communicable diseases (NCDs), which are estimated to cost India \$6.2 trillion during the period 2012-2030 (Times of India). As per the data from World Health Organization (WHO), non-communicable diseases or chronic diseases, such as cancer, heart ailments, respiratory diseases and diabetes, 38 million people dies in every year. The aging of the population increases the prevalence of chronic diseases. According to Frost & Sullivan, in Europe a total of 50% of the hospital bed occupancy is by patients suffering from chronic illnesses such as diabetes and COPD (chronic obstructive pulmonary disease). This places a huge strain on the health care infrastructure [3].

In order to track the physical status of the elderly and in the meanwhile keep them healthy, the following two daily tasks are essential: 1) real-time monitoring and analysing vital signs to early detect or predict life-threatening adverse events, 2) checking whether they are following their prescribed treatment, including taking their prescribed medicine on time. However, with rapidly aging populations, these daily tasks have brought great pressure and challenges to global health care systems. One review estimates that about 25% of the adult population does not adhere to their prescribed medication, which may lead to poor health outcomes and increased mortality. Poor medication adherence is a major problem for both individuals and health care providers. Technology improvements in health care facilities and services are highly desirable to meet the requirements of this giant group.

A complete solution for in-home health care is still missing. A desirable system should be capable of taking care of the patients from all aspects, covering personalized medication, vital signs monitoring, on-site diagnosis and interaction with remote physicians. In addition, the existing systems rarely integrate new materials or apply new manufacturing approaches, which are always the key elements for bringing new devices or solutions into healthcare fields. By taking

International Journal of Innovative Research in Science, Engineering and Technology

(An ISO 3297: 2007 Certified Organization)

Website: www.ijirset.com

Vol. 6, Issue 6, June 2017

the above-mentioned issues into consideration, an intelligent home-based healthcare IoT system, iHome Health-IoT, is proposed.

Recent technological advances in sensors, low-power integrated circuits, and wireless communications have enabled the design of low-cost, miniature, lightweight, and intelligent physiological sensor nodes. These nodes, capable of sensing, processing, and communicating one or more vital signs, can be seamlessly integrated into wireless personal or body networks for health monitoring. These network promise to revolutionize health care by allowing inexpensive, non-invasive, continuous, ambulatory health monitoring with almost real time updates of medical records via the Internet [1].

To resolve these issues, developing an intelligent medicine box equipped with medication reminders and IoT module focusing on problems faced by the elderly required to take medication. The system consists of three parts, health monitoring part, medicine box and IoT module. The sensors attached with the person and monitor the real time data and sends to the medicine box. By comparing these values with normal values, if any abnormalities are present in the values a text message will be sent to the doctor/relatives through the embedded GSM module. The medicine box compares the time with real time clock and opens the each medicine slot according to the prescribed medicine time. The doctor can reset the medicine time through IoT module.

When a patient consults a doctor or hospital, his/her details including medicine prescription should be uploaded to the web server and each patient gets a unique user ID. The information about the patient is given to cloud. So at any time the doctor or relative can visit the web page and can follow the current status of the patient. According to the value of sensors the doctor can provide on-line prescription. That is he can reschedule the time of each medicine. The system automatically reset the time schedules according with the new prescription.

The rest of the report is organized as follows. In second chapter, the related works of this paper are discussed. Chapter three describes the Methodology of the medicine box. The result and analysis of the project is presented in more details in chapter four. Finally, chapter five concludes the work and also talks about the future scope of the work.

II. RELATED WORK

In order to stabilize the condition of the patient, it is necessary for the patient to take medications regularly as per the prescribed dose and duration. Traditional plaid based medicine boxes were widely used, and many modifications on the traditional medicine box have been proposed previously.

Gomes and Benjamim et.al, proposed a system which used visual features matching in the identification of medicine boxes for visually impaired people. It uses a camera device, available in devices like computers, televisions and cell phones, to identify relevant features on medicine box. After the medicine box detection, related audios are played to inform about dosage, indications and contra indications of the medication. For each medicine separate audios are recorded. This vision system can help many visually impaired people to take the right medicine at the right time prescribed by the doctor. Experiments with 15 blind folded volunteers demonstrated that 93% of them believe that the system was useful to identify the medicine box [4].

Huai-Kuei Wu et.al, proposed pill box, where the camera is placed in inner side of the box to detect the matrix barcode and the medicine bag. A hardware module above the box was used to provide pill reminding and alarm functions. After visiting a doctor and returning home, a patient need only scan the matrix barcode using the camera of the pillbox, and all medicine related information will be loaded into the pill box. After the matrix barcode is scanned, the patient places the medicine bags in the pill box without dispensing the medicine in to the cell. This method is suitable for the elderly who do not have access to the internet as well. Furthermore, because private medical

International Journal of Innovative Research in Science, Engineering and Technology

(An ISO 3297: 2007 Certified Organization)

Website: www.ijirset.com

Vol. 6, Issue 6, June 2017

information is not transmitted via the internet, the risk of information theft is greatly reduced. Moreover, if an internet connection does exist, then patients can search for their medicine information from the hospital database [5].

Brianna Abbey et al. proposed the smart pill box in 2012. The purpose of this system was to develop a medication device that increased medication compliance, monitored medication taking behaviour, and communicated with pharmacists. The device consists of 28 chambers that are placed in seven columns made up of four rows. Each column represents each day of a week. The 4 rows represent four distinct dosage times in a day. The LED light located behind each chamber provides the light source for the patients. The light also used as the indication for the ambient light sensor which is used to detect the light when the pills are removed from the chamber [6].

Shih-Chang Huang et.al, proposed a system where the infrared sensors are fixed at the entering where the patients take the medicine package. The detection of medicine taken will be delivered to the back-end control system and record to SQL server via the wireless serial port. The time to take the medicine package away will be recorded. The motor controls the spring which is used to put the medicine packages shown as figure. A base board is installed under the spring. As the motor rotates, the packages will be pushed forward. A package drops to the entrance when it moves out of the range of the board. There is disadvantage that the number of motors increased with number of medicine type [7].

III. METHDOLOGY

The proposed system contains three section, health monitoring section, intelligent medicine box and cloud section. The Intelligent Medicine Box platform is built based on the integration of the medicine package and smart sensors via various wireless links. The focus is to regulate and optimize the accessibility of medical drugs and efficiently provide home-based health care services. The developed IoT system connects the individual home environment with hospital, emergency centre and other medical facilities and provides remote prescription and medication non-compliance service.

The health monitoring part consists of number of sensors for real time monitoring of the health parameters like blood pressure, ECG, heart rate etc. The sensors are placed on the body of the patient. The sensor output may be analog or digital. The measured values are given to the micro-controller. The RF data modem transmits the sensor values to medicine box. The block diagram of health monitoring part is shown in the Figure 1.

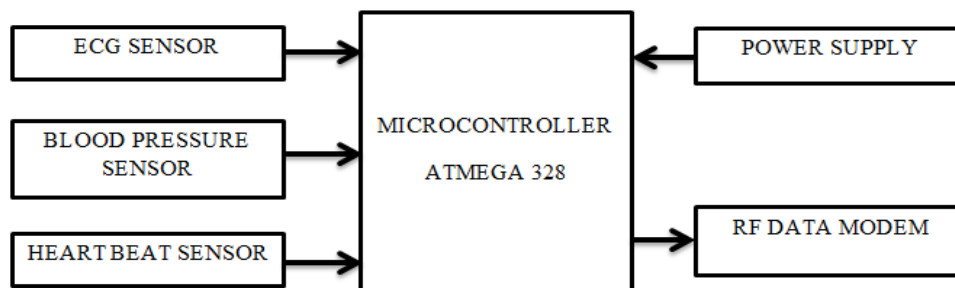

Fig.1. Health monitoring part

Biological signals, such as ECG and blood pressure and heart beat, are the most commonly used parameters for monitoring patient's physical condition. For measuring these parameters ECG sensor, blood pressure sensor and heart

International Journal of Innovative Research in Science, Engineering and Technology

(An ISO 3297: 2007 Certified Organization)

Website: www.ijirset.com

Vol. 6, Issue 6, June 2017

beat sensors are used. The data is converted to serial form and transmitted through RF module and these values of the patients are displayed on the LCD display present in the medicine box.

ECG sensor (piezoelectric sensor) is a device that piezoelectric effect to measure pressure, acceleration, strains or force by converting them to an electrical signal. Heart beat sensor measures the change in volume of blood through any organ of the body which causes a change in the light intensity through that organ. The Blood Pressure Sensor is a non-invasive sensor designed to measure human blood pressure. It measures systolic, diastolic and mean arterial pressure utilizing the oscillometric technique.

The block diagram of medicine box is shown in the figure 2. The health parameter from the transmitter section is received by a RF data modem. Generally RF modem works in half duplex mode. In the health monitoring part it act as a transmitter and in the medicine box it is used as a receiver. The EEPROM card contains the information of the patient.

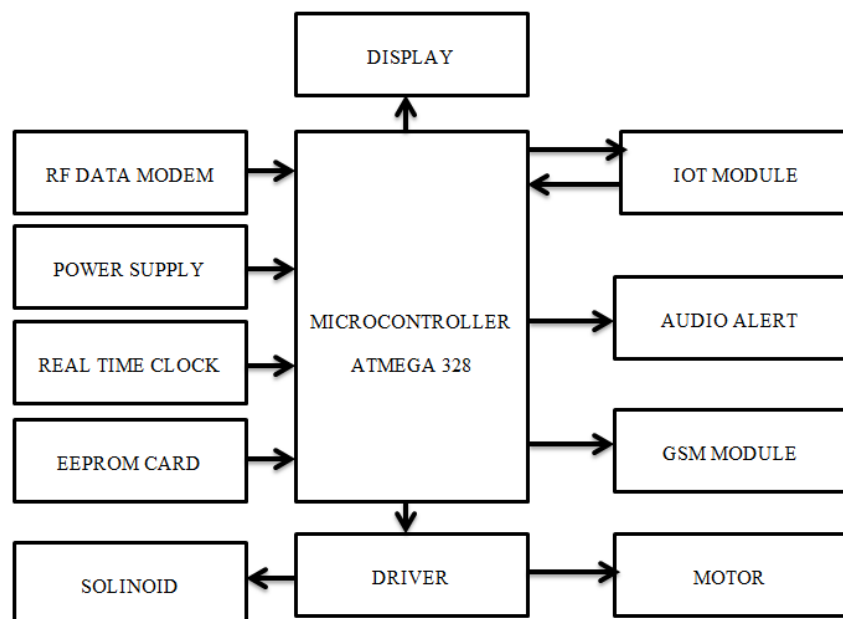

Fig.2. Intelligent medicine box

The received parameters compares with the stored threshold values, if any variation present in the measured values then a message is sent to registered number through the GSM module. All the comparison and comparing functions are done by the microcontroller. When the medicine time has been set, the medicine box will remind users or patients to take pills using sound and message. A real time clock is provided for updating the time. During the scheduled time, medicines are put forward by using a mechanical structure with two motors. The parameter from the health monitoring part is stored in a webpage using IoT module. The doctor can update the medicine time using this webpage.

International Journal of Innovative Research in Science, Engineering and Technology

(An ISO 3297: 2007 Certified Organization)

Website: www.ijirset.com

Vol. 6, Issue 6, June 2017

IV. EXPERIMENTAL RESULTS

The hardware of health monitoring section is shown in Figure 3. The three sensors, ECG, Blood pressure sensor and heartbeat sensor serially connected to the microcontroller. The values of three sensors are sends to the medicine box through the RF data modem.

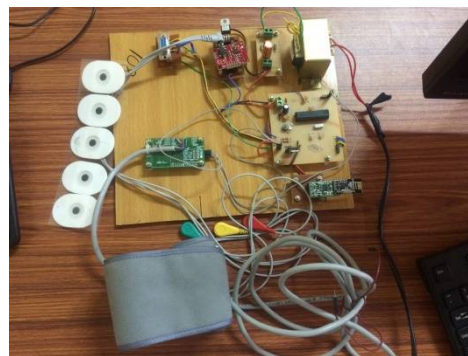

Fig.3. Hardware of health monitoring part

Blood pressure is usually expressed in terms of the systolic pressure (maximum during one heart beat) and diastolic pressure. Normal resting blood pressure in an adult is approximately 120 mmHg systolic, and 80 mmHg diastolic, abbreviated "120/80 mmHg". For a normal reading, blood pressure needs to show systolic pressure between 90 and 120, and diastolic pressure between 60 and 80.

The normal resting adult human heart rate ranges from 60 – 100 bpm. The digital pulses from the sensor are given to a microcontroller. The heart beat sensor gives the electrical pulses as output with a pulse frequency F. Then calculating the heart beat rate in BPM using the formula:

$$\text{BPM(Beats per minute)} = 60 * f$$

Where f is the pulse frequency from heart beat sensor.

Table1. Cost analysis

	Medbox with computer vision technology	Medbox with Matrix barcode	Medbox with IR sensor	Medbox with CDM technology	Implemented system
Components	24000	10000	7000	15000	12000
Software	5000	3000	1000	1000	0
Implementation	1000	5000	1000	7000	2000
Total cost	30000	18000	9000	23000	14000

Table 1. shows the different values of the sensor. If the sensor values above or below the normal values a message is send to the registered number. In the GSM module the user can store more than one numbers. Then the message will be send to all these registered numbers. The sensor values from the health monitoring part are received and displayed on LCD and stores in web-page.

International Journal of Innovative Research in Science, Engineering and Technology

(An ISO 3297: 2007 Certified Organization)

Website: www.ijirset.com

Vol. 6, Issue 6, June 2017

The hardware of medicine box is shown in figure 4. It consists of microcontroller unit, GSM module, APR module etc. The system checks patient's EEPROM card and if it is valid, the system starts to operate and LCD displayed a message "VALID CARD". Then it displayed information related to the patient like name, sensor values. This message also showed when security card is put on the reader.

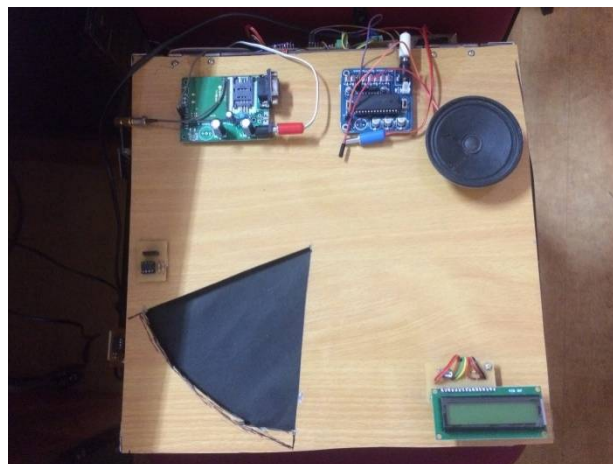

Fig.4. Hardware of medicine box

Once the boxes are emptied after medicine consumption by the patient, and then refill the boxes with the medicines. For that a EEPROM card is used. If the card is valid the medicine box will be open and the user can refill the medicine. Once the card is removed system automatically going to locked stage. During scheduled time of medicine the LCD displayed the medicine slot number.

As per the number of slots/sections in the medicine box the degree of rotation of motor varies. For example if 3 types of medicine present then each 180 degree servo motor rotates 60, 120 and 180 degree for medicine section 1,2 and 3 respectively. After this rotation the tray motor rotates according to the size of each slot. Here each section divided into 3 slots representing 3 times of a day. After a 1 minute delay the tray motor rotates anticlockwise and the servo motor rotates opposite for reaching initial condition.

Atmega328 processor wired up on a circuit board with a 16 MHz crystal and a couple of 22 pF capacitors. Two of the capacitors are 0.1 uF for decoupling the power line (to reduce noise). There is also another 0.1 uF capacitor and a 10K resistor which provides a reset "pulse" when the RTS line is brought low during bootloading. There is also an optional LED and current-limiting resistor (about 120 ohm) for testing.

V. CONCLUSION

The intelligent medicine box and health monitoring and management system can effectively solve the error or negligence in the field of medications. The system consists of smart sensors attached to a human body for physiological monitoring and intelligent medicine packaging to the daily medicine management. The medical data collected from the sensors are stored in a webpage and history acquired for the patients are personal in nature. Hence the system ensures security of the highest order for the medical data on cloud storage.

International Journal of Innovative Research in Science, Engineering and Technology

(An ISO 3297: 2007 Certified Organization)

Website: www.ijirset.com

Vol. 6, Issue 6, June 2017

Medicine box offers a promising solution for the medication non-compliance problem by automatically reminding the user and providing a required amount of medicine on time. This helps in the swift transformation from Hospital-Centric medical treatment to Home-Centric health care and finally brings about ubiquitous and personalized health care. According to the on-line rescheduling option the doctor can reset the timing of medicines by analysing the sensor values present in a webpage. This system does not need any special training for operating thus it can be useful for common people, especially disabled and aged people.

The Health system can combine the health network, telemedicine, and emergency and medication management services. By improving the mechanical design of medicine box the amount of the medicines in the outlet can be controlled. The medicine name and the related disease can be displayed or play using LCD or APR module. Real time health monitoring system using ARDUINO can be implemented in hardware using different types of sensors to detect the health conditions of the patients in critical sites. The continuous monitoring of health can be improving the safety of the patient.

The implemented systems have a webpage that contains the list of medicines, which is currently used by the patient. There is no option for prescribe new medicine by online. If the medication list is given in the web-page, the doctor can choose new medicines according to patient's health condition. For accurate refilling, there is a possibility to add a keypad, for manually adding the number of medicine inside the box. A single system can be useful for more than one patient. Multiple users can access the system by using their own EEPROM card. For that the medicine box need to contain more number of sections and each section is utilized by particular user.

REFERENCES

- [1] Geng Yang, Li Xie, MattiMntysalo, Xiaolin Zhou,Zhibo Pang, Li Da Xu, Sharon Kao-Walter, Qiang Chen, LirongZheng, "A Health-IoT Platform Based on the Integration of Intelligent Packaging, Unobtrusive Bio-Sensor and Intelligent Medicine Box", IEEE Transactions on Industrial Informatics, 2013.
- [2] J.A.Cramer, A.Roy, A.Burrell, C.J.Fairchild, M.J.Fuldeore, D.A.Ollendorf, et al., "Medication compliance and persistence: terminology and definitions", Value Health: J IntSocPharmacoeconom Outcomes Res, 11 (1), pp. 4447, 2008.
- [3] Frost & Sullivan, "European Remote Patient Monitoring Market", Report B519-56, June 2005.
- [4] Xiankleber C. Benjamim, Rafael B. Gomes, Aquiles F. Burlamaqui, Luiz MarcosG, "Visual Identification of Medicine Boxes Using Features Matching", IEEE, 2012.
- [5] Huai-Kuei Wu, Chi-Ming Wong,et.al., "A Smart Pill Box with Remind and Consumption Confirmation Functions", IEEE 4th Global Conference on Consumer Electronics (GCCE), 2015.
- [6] B.Abbey, A.Alipour, C.Camp, C.Hofer, "The Smart Pill Box", in proceedings of the Rehabilitation Engineering and Assistive Technology Society of North America, 2012.
- [7] Shih-Chang Huang, Hong-Yi Chang, Yu-Chen Jhu, Guan-You Chen, "The Intelligent Pill Box - Design and Implementation", ICCE-Taiwan2014.