

# Dynamic Voltage Restorer for Mitigation of Voltage Sag and Swell

Mohammad Imran<sup>1</sup>, S.M.Kulkarni<sup>2</sup>, S.V. Murkute<sup>3</sup>

P.G. Student, Department of Electrical, Electronics and Power Engineering, PESCOE, Aurangabad, Maharashtra India<sup>1</sup>

Associate Professor, Department of Electrical, Electronics and Power Engineering, PESCOE, Aurangabad, India<sup>2</sup>

Associate Professor, Department of Electrical, Electronics and Power Engineering, PESCOE, Aurangabad, India<sup>3</sup>

**ABSTRACT:** The electrical energy is one of the easily used forms of energy. It can be easily converted to other forms of energy. However, the quality of power supplied is affected by various internal and external factors of the power system. The presence of harmonics, voltage and frequency variations deteriorate the performance of the system. In this paper the frequently occurring power quality problem and its mitigations is discussed.

**KEYWORDS:** Voltage sag, Swell, Interruption

## I. INTRODUCTION

Electrical energy is the most efficient and popular form of energy and the modern society is heavily dependent on the electric supply. The life cannot be imagined without the supply of electricity. At the same time the quality and continuity of the electric power supplied is also very important for the efficient functioning of the end user equipment. Most of the commercial and industrial loads demand high quality uninterrupted power. Thus maintaining the qualitative power is of most important. (Sandeepkumar report)

The quality of the power is affected if there is any deviation in the voltage and frequency values at which the power is being supplied. This affects the performance and life time of the end user equipment. Whereas, the continuity of the power supplied is affected by the faults which occur in the power system. So to maintain the continuity of the power being supplied, the faults should be cleared at a faster rate and for this the DVR system designed to operate without any time lag.

Faults at either the transmission or distribution level may cause voltage sag or swell in the entire system or a large part of it. Also, under heavy load conditions, a significant voltage drop may occur in the system. Voltage sag and swell can cause sensitive equipment to fail, shutdown and create a large current unbalance. The voltage dip magnitude is ranged from 10% to 90% of nominal voltage and with duration from half a cycle to 1 min and *swell* is defined as an increase in rms voltage or current at the power frequency for durations from 0.5 cycles to 1 min. typical magnitudes are between 1.1 and 1.8p.u.

## II. RELATED WORK

We came to know the detailed comparison of D-STATCOM & DVR which is done by comparing load voltage and load current waveforms. Various results were obtained by Matlab simulation and analysed by using three different types of short circuit faults. The controlling of and D-STATCOM & DVR is done. From the simulation result it is seen that compensated load voltage and load current waveforms by using DVR is much better than the compensated load voltage and load current waveforms by using D-STATCOM.

# International Journal of Innovative Research in Science, Engineering and Technology

(An ISO 3297: 2007 Certified Organization)

Website: [www.ijirset.com](http://www.ijirset.com)

Vol. 6, Issue 6, June 2017

Detail numerous reasons why DVR is preferred over other devices:

1. If compared with Static VAR Compensator, SVC has no ability to control active power flow.
2. DVR is less expensive compared to the UPS.
3. DVR has a relatively higher energy capacity and costs less compared to SMES device.
4. DVR is smaller in size and costs less compared to D-STATCOM
5. DVR is power efficient device compared to the UPS.

## Different Power Quality Issues

### Voltage Sags

A *sag* is a decrease to between 0.1pu and 0.9 pu in rms voltage or current at the power frequency for durations from 0.5 cycle to 1 minute (min) and common problems for such situation are system faults, addition of large load, etc.

### Swells

A *swell* is defined as an increase to between 1.1pu and 1.8 pu in rms voltage or current at the power frequency for durations from 0.5 cycle to minute (min). Common causes for voltage swell are switching off a large load, energization of a capacitor bank, etc

### Interruption

An *interruption* occurs when the supply voltage or load current decreases to less than 0.1 pu for a period of time not exceeding 1 min. Interruptions can be the result of power system faults, equipment failures. [1][2]

## DVR STRUCTURE:

Dynamic Voltage Restorer is one of custom power device specially used to maintain the load voltage constant in the distribution system. DVR will be in standby mode during normal operation and when the control circuit detects any disturbance in the supply voltage DVR will inject the required voltage. In-phase compensation technique is used to compensate the voltage sag/swell in which only voltage magnitude is compensated [3]. DVR consist of an injection transformer, Voltage Source Converter (VSC), harmonic filter, storage device and control system as shown in Fig.1

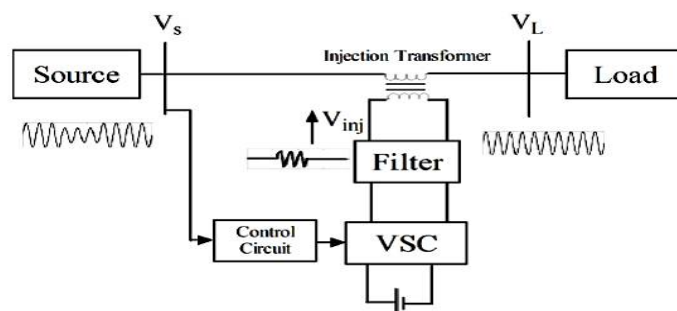

Fig: 1 Structure of DVR

## III. SYSTEM MODELLING

Dynamic Voltage Restorer is connected in between Distribution transformer and Sensitive load by means of a Series injection transformer, and works as a series compensating device. DVR consist of an injection transformer, Voltage Source Converter (VSC), harmonic filter, storage device and control system as shown in Fig:1[4]

# International Journal of Innovative Research in Science, Engineering and Technology

(An ISO 3297: 2007 Certified Organization)

Website: [www.ijirset.com](http://www.ijirset.com)

Vol. 6, Issue 6, June 2017

## *Injection Transformer*

Injection transformer is used to connect the DVR to the distribution network via High Voltage winding and injects the compensating voltage generated by VSC after the detection of any disturbance in supply voltage by control circuit. Another main task of injection transformer is that it will limit the coupling of noise and isolate VSC and control circuit from the system.[5]

## *Voltage Source Converter (VSC)*

VSC is a power electronic device used to generate the compensating voltage. Output voltage of VSC should be

- Pure sine wave and balanced
- Phase sequence as that of system
- Of required magnitude
- For required duration
- Practically instantaneous

## *Harmonic Filter*

The main task of harmonic filter is to keep the harmonic voltage content generated by the voltage source converters to the permissible limit.

## *Storage device*

It is basically used to supply the necessary energy to VSC to generate the compensating voltage. In this paper DC voltage source is used for this purpose

## *Control circuit*

Control circuit continuously monitors the supply voltage. The function of control system is to detect the disturbance in the supply voltage, compare it with the set reference value and then generate the switching pulses to the VSC to generate the DVR output voltages[6][7].

## IV. SIMULATION AND RESULTS

### **A) Simulation of DVR for Voltage Sag:**

A Simulation on DVR is been done in MATLAB environment as shown in fig:2. A 3-phase programmable voltage source is used as AC voltage source, which further is connected to the load with a series connection of injection transformer. This source is programmed to create a sag between the duration of 0.2 to 0.4 seconds. As shown in fig 2 DVR generates a voltage to compensate this voltage sag for specific period of fault, Voltage sag as shown in fig 2(a) The Magnitude of compensation injection voltage as shown in fig 2(b). Further fig.3(c) shows the Compensated load voltage with Fault cleared.

# International Journal of Innovative Research in Science, Engineering and Technology

(An ISO 3297: 2007 Certified Organization)

Website: [www.ijirset.com](http://www.ijirset.com)

Vol. 6, Issue 6, June 2017

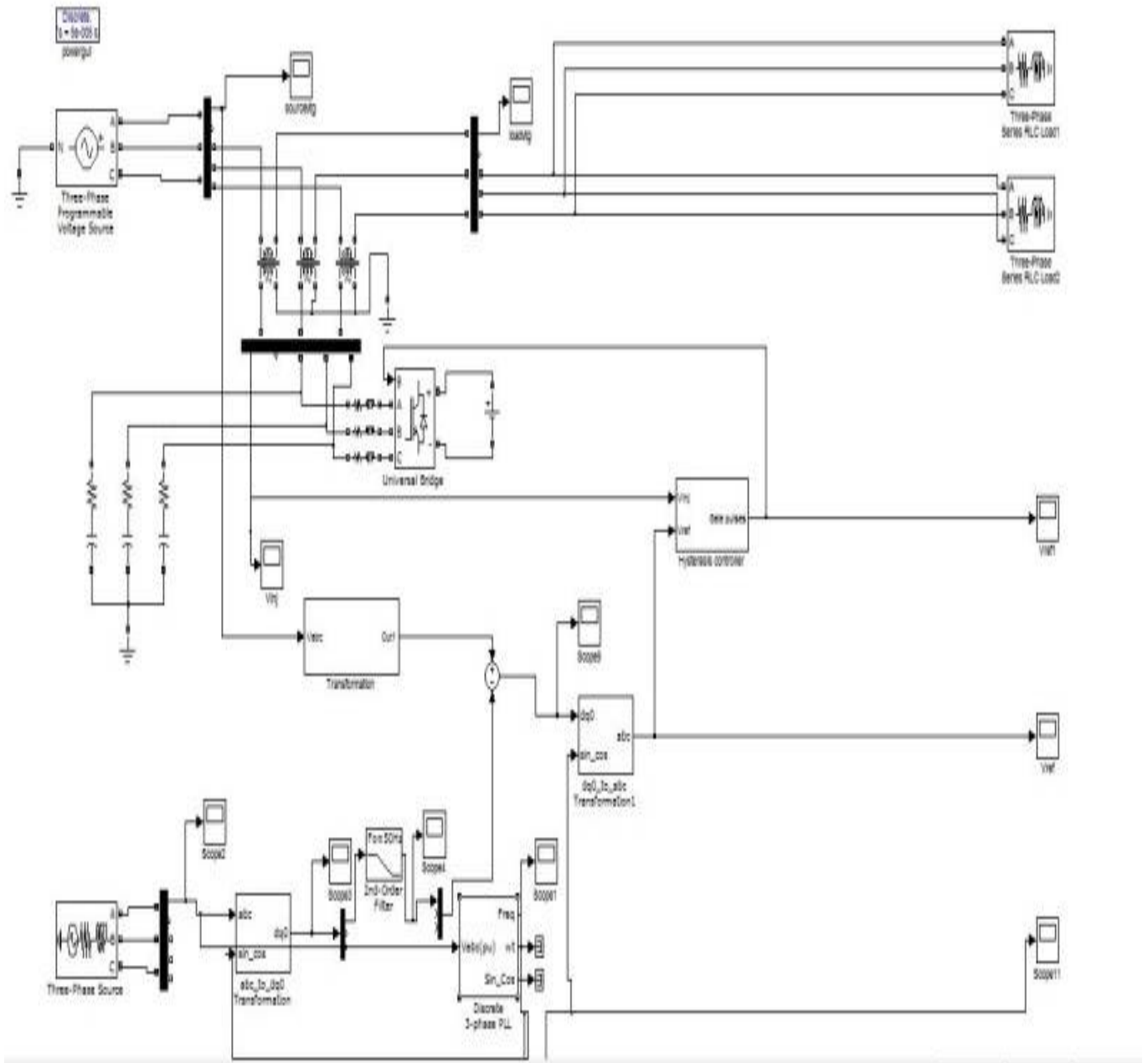

Fig: 2 Simulation of DVR for Sag and Swell

# International Journal of Innovative Research in Science, Engineering and Technology

(An ISO 3297: 2007 Certified Organization)

Website: [www.ijirset.com](http://www.ijirset.com)

Vol. 6, Issue 6, June 2017

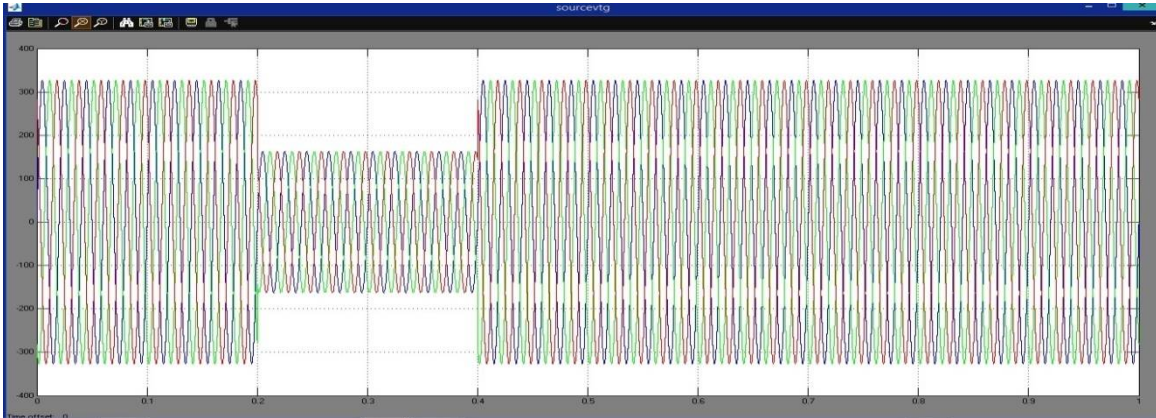

Fig:2(a)

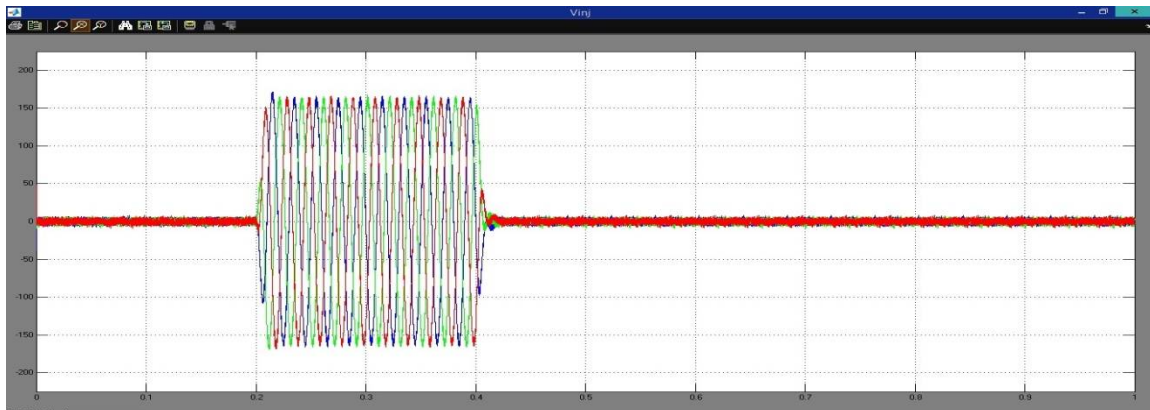

Fig:2(b)

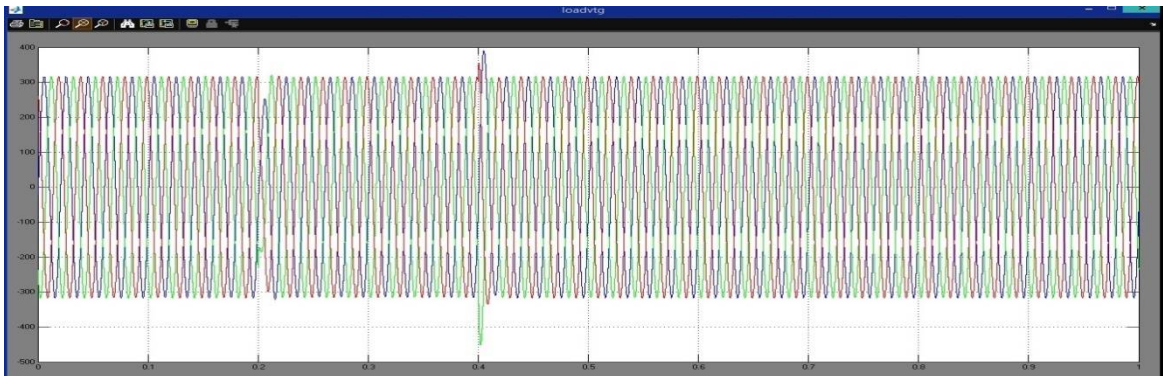

Fig:2(c)



## B) Simulation of DVR for Voltage Swell:

Fig: 2 show the diagram for Simulations under swell condition, in this case the three phase AC source is programmed to create a swell between the duration of 0.2 pu to 0.3 pu. Within this period of time the DVR absorbs the excessive swelled voltage from the transmission line via injection transformer. This absorbed voltage is used to charge the storage within DVR. Fig 2(d) shows the swell in source voltage, where 2(e) shows the compensation done by DVR which results in the steady load voltage as indicated in fig 2(f).

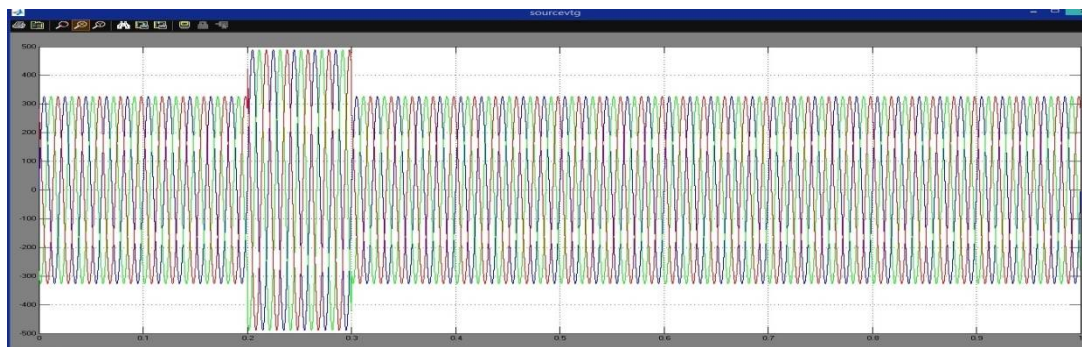

Fig: 2(d)

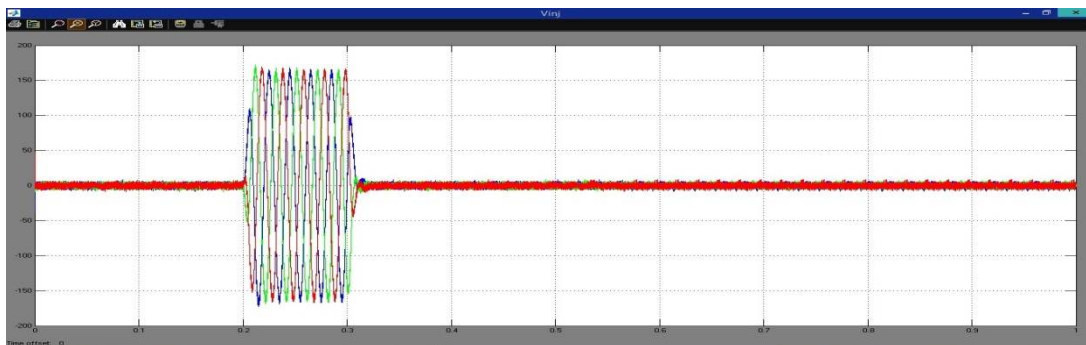

Fig: 2(e)

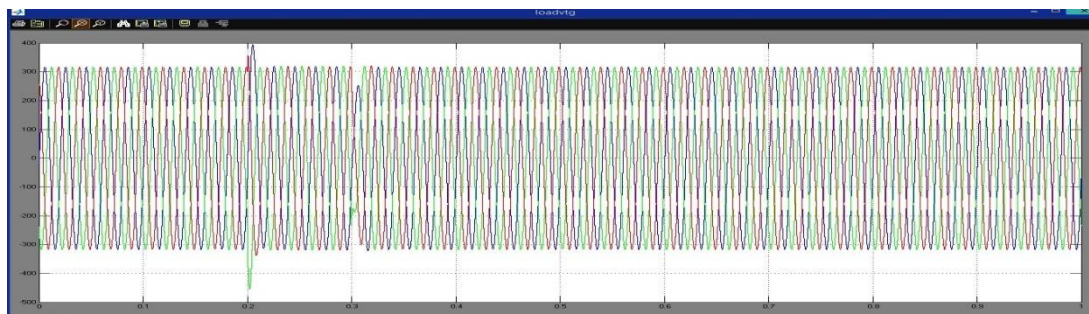

Fig: 2(f)

# International Journal of Innovative Research in Science, Engineering and Technology

(An ISO 3297: 2007 Certified Organization)

Website: [www.ijirset.com](http://www.ijirset.com)

Vol. 6, Issue 6, June 2017

## V. CONCLUSION

This paper describes the basic structure and principle of Dynamic Voltage Restorer (DVR) Different conditions are taken for creating voltage Sag/swell. Voltage sag and swell are created by programmable source leading to a three phase fault. Performance of DVR for these conditions is verified in MATLAB simulink. Results show that DVR is the best device to mitigate voltage sag/swell and thus maintains the load voltage constant.

## REFERENCES

- [1] IEEE Std. 1159-1995, "Recommended Practice for Monitoring Electric Power Quality".
- [2] Roger C. Dugan, Electrical Power Systems Quality, Editorial McGrawHill, 1996.
- [3] A. Ghosh and G. Ledwich, Power Quality Enhancement Using Custom Power Devices, Kluwer Academic Publishers, 2002.
- [4] Chellali Benachaiba, Brahim Ferdi, "Voltage Quality Improvement Using DVR," Electric Power Quality and Utilization, Journal Vol. XIV, No.1, 2008.
- [5] Himdari Ghosh, Pradip Kumar Shah and Gautam Kumar Panda, "Design and Simulation of a Novel Self Supported Dynamic Voltage Restorer (DVR) for Power Quality Improvement," International Journal of Scientific and Engineering Research, Volume 3, Issue 6, June-2012.(5)
- [6] Kantaria, R. A.; Joshi, S.K.; Siddhapura, K. R., "A novel technique for mitigation of voltage sag/swell by Dynamic Voltage Restorer (DVR)," Electro/Information Technology (EIT), 2010 IEEE International Conference on , vol., no., pp.1,4, 2010, May-2010.
- [7] Kong Shuhong; Yin Zhongdong; Shan Renzhong; Shang Weidong, "A Survey on the Principle and Control of Dynamic Voltage Restorer," Energy and Environment Technology,