

International Journal of Innovative Research in Science, Engineering and Technology

(An ISO 3297: 2007 Certified Organization)

Website: www.ijirset.com

Vol. 6, Issue 6, June 2017

Experimental Analysis and Performance Comparison between Evaporative Cooling System and Air Conditioning System

Sachin Tale¹, Amol Gawali²

P.G. Student, Department of Mechanical Engineering, Deogiri Engineering College, Aurangabad, Maharashtra, India¹

Assistant Professor, Department of Mechanical Engineering, P.E.S Engineering College, Aurangabad,

Maharashtra, India²

ABSTRACT: Air-conditioning plays an essential role in ensuring occupants thermal comfort. A standard air conditioning unit cools warm air it has taken from the rooms in your home by passing it over a set of coils that are filled with a refrigerant. The cooled air is then blown back into your home until the room or rooms reach the desired temperature. However, building's electricity bills have become unaffordable. Yet the commercially dominant cooling systems are intensively power-consuming ones, i.e. vapour compression systems. Now days due to energy crisis and harmful effect to environment, there is more and more urgent need of energy saving in air conditioning and water cooling demands in mainly consideration of all the free cooling techniques. This paper aims to review the recent developments concerning evaporative cooling technologies that could potentially provide sufficient cooling comfort, reduce environmental impact and lower energy consumption in buildings. Evaporative cooling is nothing but A swamp cooler is a relatively simple open system. A fan draws in air from the outside and forces it through a set of damp pads. These pads are moistened by a small pump that draws water from a pan below the unit. The air causes the water to evaporate, which in turn cools the air that is pushed into your home. Among them evaporative cooling is well known technique from long time which gives good results and wide number of applications in residential, commercial, agricultural, and institutional buildings to industrial applications like as spot cooling in power plants, foundries, etc. So in this paper the evaporative cooling, its potential, and different trends in evaporative cooling are studied, which are environment friendly as it uses only natural energy as latent heat of water

KEYWORDS: Adiabatic Cooling, Vapour compression cycle, Eco friendly, Power Saving.

I. INTRODUCTION

Evaporative cooling is the oldest form of air conditioning ever used. Evaporative cooling is a natural phenomenon that occurs when moving air passes over a wetted medium or water source, i.e. fountain, river, sea, shower, etc. The conversion of sensible heat to latent heat causes a decrease in the ambient temperature as water is evaporated providing useful cooling. Effective cooling can be accomplished by simply wetting a surface and allowing the water to evaporate. Evaporative cooling is an energy efficient and environmentally friendly air conditioning technology. The lower the relative humidity, the greater the cooling effect that is possible when moisture is added. This system contain the adiabatic cooling pad small fan and pump is required to circulate the water [1]. This all component produce the same evaporative effect as the vapour compression system is produce.

While vapour compression system in air conditioning utilise the phase change method of refrigeration rejects heat at the condenser and give the cooling effect at evaporator. Compressor, condenser, evaporator and expansion device is the some main component which produce the refrigerating effect to cool the air.[2] With the help of the humidifier it also add required amount of the humidity in air for human comfort. Refrigerating effect produce by the refrigeration system is .As we overlook, both system are made for comfort cooling of the human being but the main and identical difference between these two system is their variable working principle which shows one system i.e. adiabatic cooling is eco

International Journal of Innovative Research in Science, Engineering and Technology

(An ISO 3297: 2007 Certified Organization)

Website: www.ijirset.com

Vol. 6, Issue 6, June 2017

friendly while VCC mean Ac system contain greenhouse gases in it. In this research paper two systems performance compare on the basis of their cooling effect, relative humidity factor and power consumption and efficiency of the both system[1,2].

II. EVAPORATIVE COOLING SYSTEM

To understand the cooling effect produced by the Evaporative device i.e. dessert cooler it is necessary to understand the working principal of the same. Figure shows the basic principle of the evaporative cooling system and its working on the psychometric chart Fig 1b. This figure indicating the drop down of temperature with the help of the water and increase in humidity. While Fig.1c showing the actual setup of evaporative cooling setup. This setup contain the cellulose pad, fan having 36 cm in diameter and one water pump which continuously keep wet to the cellulose pad. To get the evaporation effect honeycomb pad of evaporative pad is used who's efficiency up to the 90%. Fig.1b showing the psychometric chart in which the temperature of air is decreasing from with the difference of 8 degree to 10 degree Celsius with lower wet bulb temperature. This system to able to increase the humidity up to 70% while its advantages and disadvantages are given below.

Advantages of the evaporative cooling system

1. The main advantages of evaporative coolers are their low cost and high effectiveness.
2. Permitting a wide range of applications and versatility in the buildings, dwellings, commercial and industrial sectors and also direct evaporative devices act like filters, removing dust particles in air
3. It requires no special skill to operate and therefore is most suitable for rural application.
4. Highly efficient evaporative cooling systems that can reduce energy use, Less expensive to install and operate and It can be easily made and maintained[4,5,6]

Limitation of the evaporative cooling system. While discussing disadvantage it's not harmful or inefficient but it has certain limitation of working mansion as below

1. The water consumption associated to the operation of these systems, which is a scarce resource in dry and hot climates, where these systems best work. Water high in mineral content leave mineral deposits on the pads and interior of the cooler gets damaged
2. Direct Evaporative Cooling (DEC) is only suitable for dry and hot climates. In moist conditions, the relative humidity can reach as high as 80%, such a high humidity is not suitable for direct supply into buildings, because it may cause warping, rusting, and mildew of susceptible materials.[8]

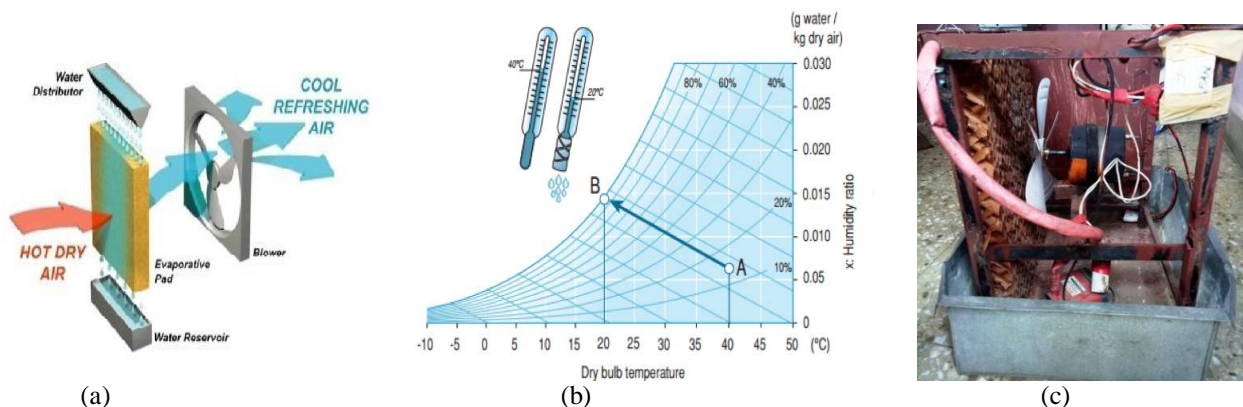

Figure 1 (a) Simple direct evaporative cooling system (b) Psychrometric process of Adiabatic Cooling (c) Actual Setup

International Journal of Innovative Research in Science, Engineering and Technology

(An ISO 3297: 2007 Certified Organization)

Website: www.ijirset.com

Vol. 6, Issue 6, June 2017

III. VAPOUR COMPRESSION SYSTEM

The most commonly used refrigeration cycle is the vapour-compression refrigeration cycle which involves four main components: a compressor is the heart of any refrigeration system which is shown in figure 2a. Its function is to compress the refrigerant at high pressure and temperature., a condenser, Condenser is heat transfer surface like evaporator. Heat from the hot refrigerant vapour passes through wall of condenser to condensing medium. As result of losing heat to the condensing medium., an expansion valve which lowers down the pressure of system and also lowers the temperature and an evaporator where the cooling effect is produced. This process is shown on T-s Diagram in figure 2b. The refrigerant enters the compressor as a vapour and is compressed to the condenser pressure. It leaves the compressor at a relatively high temperature and cool and down and condenses as it flows through the coils of the condenser by rejecting heat to the surrounding medium.[3,4] If then enters a capillary tube where its pressure and temperature drops drastically due to the throttling effect. The low temperature refrigerant then enters the evaporator, where it, evaporates absorbing heat from the refrigerated space. The cycle is completed as the refrigerant leaves the evaporator & re-enters the compressor. Figure 2.a showing the ideal vapour compression system used for the air conditioning while figure 2b shows the behaviour of refrigerant on ph chart .Figure 2c & d shows the actual setup used to find out result and effect .It containing the all vapour compression cycle part describe in the above paragraph.[6, 7]

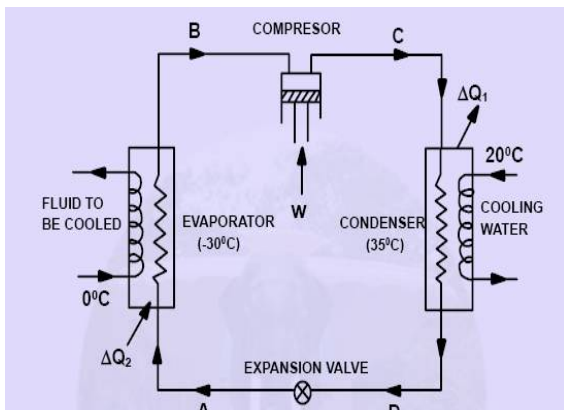

Figure 2(a) Vapour compression system

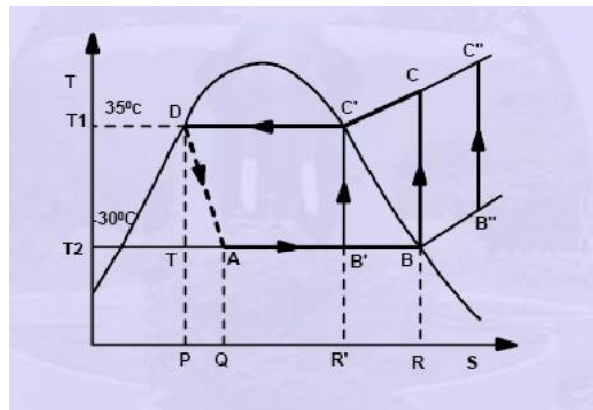

Figure 2 (b) T-S diagram of VCC



Figure 2 (c) Actual Setup front side



Figure 2 (d) Actual setup Backside

International Journal of Innovative Research in Science, Engineering and Technology

(An ISO 3297: 2007 Certified Organization)

Website: www.ijirset.com

Vol. 6, Issue 6, June 2017

IV. EXPERIMENTAL RESULTS

Setup description and actual experimental setup is shown in figure 1. C and Figure 2.c. Experimental result is based on the power consumption by both system ,effect of system and efficiency of system while it is keep at mind system should provide more comfort to the human and working in the adverse condition. Evaporative coolers need almost half hour to cool 10 ×10 feet room while it is able to cool such a space with lower power consumption.

The humidity factor of evaporative cooling system mainly depend on the difference between dry bulb temperature and wet bulb temperature .As this difference is increases the amount of the cooling and humidity is increases which shows by the figure.3a on x axis time required for cooling is present while on y axis indicate the temperature..Similarly air condition system able to drop down the temperature of room within 10 to 15 minute with controlled humidity .The comparison of the temperature reduction with help of evaporative cooling and Air conditioning system given on graph.

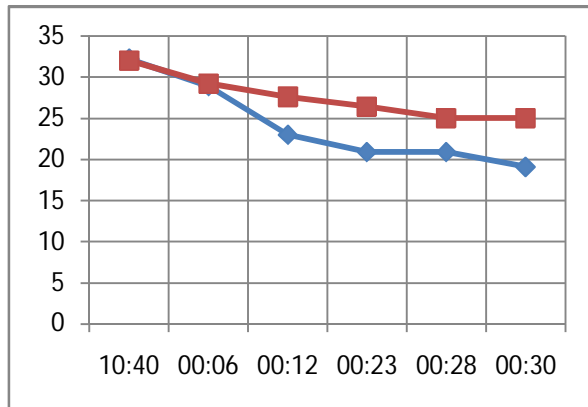
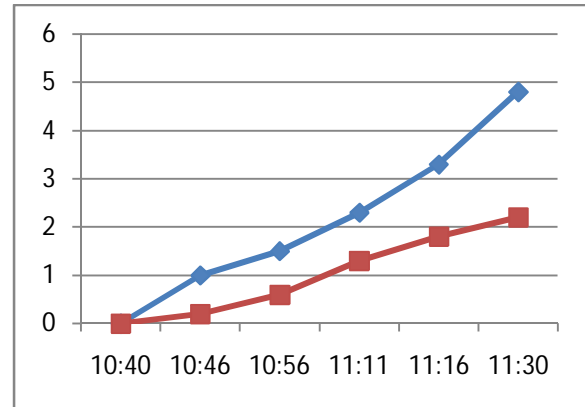

Figure 3 (a) Temperature vs Time graph



(b) Temperature vs Power consumption

Fig 3.a clearly shows that the time require to drop down room temperature in case of evaporative cooling is more than the air conditioning system. Here one more thing is need to pay attention that what is the temperature and humidity we are getting through the direct evaporative cooling is uncontrolled and we are not able to predict because of changing environmental condition.

Figure 3.b shows the graph in which power consumption given by the evaporative system and air conditioning system which clearly shows the power consumption is very low in evaporative cooling system while VCC is taking more power at same point and compressor and condenser fan, evaporator fan is main power consuming component.

V. CONCLUSION

As per the experiment and established studies present it is conclude that Evaporative cooling or Dessert coolers are efficient and eco friendly in the summer only while in other seasons it is less efficient. Also evaporative cooling system may not require much maintenance; some units do require regular service throughout the summer to maintain an optimal level of cooling. They also require seasonal maintenance. Evaporative cooling units use far less power than air conditioning units, but they do use more water. One more thing is noticeable here is that we can use this type of system in tropical regions where the difference between the dry bulb temperature and wet bulb temperature is more. In air conditioning case this type of system is used through the year by controlling the amount of the temperature and humidity. Power consumption is the drawback of this system and higher operating cost required to air conditioning.

International Journal of Innovative Research in Science, Engineering and Technology

(An ISO 3297: 2007 Certified Organization)

Website: www.ijirset.com

Vol. 6, Issue 6, June 2017

REFERENCES

- [1] Suvarna V.Mehere, Krunal P.Mudafale, Dr.Sunil.V.Prayagi, "Review of Direct Evaporative Cooling System With Its Applications", International Journal of Engineering Research and General Science,Volume 2, pp.995-997, 2014.
- [2] O. Amer, R. Boukhanouf, and H. G. Ibrahim, "A Review of Evaporative Cooling Technologies", International Journal of Environmental Science and Development, Vol. 6,pp.111-115, 2015.
- [3] Rajesh Maurya*, Dr. Nitin Shrivastav, Vipin Shrivastava, "Performance and Analysis of an Evaporative cooling System: A Review", International Journal of Scientific & Engineering Research, Volume 5,pp.1065-1069 2014.
- [4] J. R. Camargo, C. D. Ebinumab, and S. Cardoso Engenharia Térmica , " Three Methods To Evaluate The Use Of Evaporative Cooling For Human Thermal Comfort ,Vol. 5, pp.11-16 2006.
- [5] Sirelkhatim K. Abbouda*, and Emad A. Almuhanha, "Improvement of Evaporative Cooling System Efficiency in Greenhouses", Int. J Latest Trends Agr. Food Sci. Vol-2,pp.84-88,2012.
- [6] Rasika D Deshmukha , Samir Jdeshmukhb ,Dipak A Warkec, "Theoretical Analysis on Heat and Mass Transfer in a Direct Evaporative Cooler", International Journal of Innovative and Emerging Research in Engineering Volume 2, pp.152-156,2015.
- [7] B.G Jahun1, S.A. Abdulkadir, S. M. Musa, Huzaifa Umar , " Assessment of Evaporative Cooling System for Storage of Vegetables International Journal of Science and Research"vol.5 issue 1.pp.1197-1200,2015.
- [8] .N. Lechner, "Heating, Cooling, Lighting: Sustainable Design Methods for Architects", New Jersey, U.S.A,Wiley, 2009.