

**International Journal of Innovative Research in Science,
Engineering and Technology**

(An ISO 3297: 2007 Certified Organization)

Website: www.ijirset.com

Vol. 6, Issue 6, June 2017

Solar PV Fed DC Motor Speed Control Using Microcontroller Based Power Electronic Controller

Sneha M. Dalavi, Prof. Shubhangi S. Landge

ME Student, Department of Electrical Engineering, All India Shri Shivaji Memorial Society, Institute of Information
Technology, Kennedy Road, Pune, India

Professor, Department of Electrical Engineering, All India Shri Shivaji Memorial Society, Institute of Information
Technology, Kennedy Road, Pune, India

ABSTRACT: In this paper an attempt is made to design and fabricate IC MPPT algorithm using PIC microcontroller for PV array, so that it will extract maximum available solar power used for charging the battery. Incremental conductance MPPT using direct control method is used in such a way that duty cycle of boost converter is adjusted inside the algorithm. Thus, there is no need to use any other control loop. Incremental Conductance (IC) gives a better performance, faster tracking time and has no oscillation. The hardware makes use of Solar panel, boost converter, battery, PIC 16F877A microcontroller, speed sensor and MOSFET for speed control of PMDC motor using electronic armature voltage control method. Motor is tested for set speed of 500- 1500RPM under load and no load conditions. It has been seen that PI controller will maintain the speed of motor up to given set speed by increasing or decreasing voltage applied across armature of motor.

KEYWORDS: MPPT, DC Motor, Incremental Conductance, PV array.

I. INTRODUCTION

Photovoltaic PV energy conversion is now recognized to be the most widely accepted method of using renewable energy sources to benefit society, especially in developing countries like India and remote areas. PV arrays provide direct conversion of solar energy into electrical energy without producing environmental pollution. Recognizing these facts, extensive research and development efforts are devoted to photovoltaic. Especially in countries like India where the government imports oil from other countries, Harvesting PV energy which is available in abundance throughout the year will be very important. One of the most popular applications of the PV array utilization is the water pumping system using DC motor as drive. However to utilize PV power more efficiently, load matching between PV array and DC motor as an intermediate matching circuitry is essential. Utilization of boost converters has been considered for this purpose. Solar energy is one of the potential renewable energy sources and it offers replacement to depleting fossil fuels. The main disadvantages of PV are it needs high installation cost and it has low efficiency. To improve its efficiency, a PV must work at maximum power point which always changes and depends on sun irradiation and temperature. Changing temperature and irradiation shifts the maximum power point and reduce the PVs efficiency. Generally the maximum power point tracking (MPPT) is implemented by a power electronic circuit which provides an interface between PV and load. Here boost converter is used as interfacing circuit between solar panel and PMDC motor. Different MPPT techniques are used such as constant voltage control, perturb and observe incremental conductance, fuzzy logic and neural network. Perturb and observe method is easy to implement but it offers increased oscillations at maximum power point area and not suitable for environment suffering from rapid changes of temperature and irradiations. Fuzzy logic has complex fuzzy rules design and neural network require understanding of learning process. Among these methods, Incremental Conductance (IC) offers a better performance, faster tracking time and has no oscillation. A DC to DC converter is required for implementing MPPT. The DC-DC converter delivers the maximum power from solar panel to load i.e. motor by adjusting the duty cycle and able

International Journal of Innovative Research in Science, Engineering and Technology

(An ISO 3297: 2007 Certified Organization)

Website: www.ijirset.com

Vol. 6, Issue 6, June 2017

to distribute a maximum power. Some common DC-DC converter topologies for implementing MPPT are Buck converter, Boost converter, Cuk converter and Buck Boost converter.

The paper is organized as follows. Section II presents Incremental conductance MPPT method in detail. Section III presents block diagram of solar PV fed DC motor speed control using microcontroller based power electronic controller. Section IV presents simulation and results of solar PV fed DC motor speed control system. Section V presents hardware implementation and results of solar PV fed DC motor speed control system. In section VI conclusions and future scope are summarized.

II. INCREMENTAL CONDUCTANCE MPPT

PV arrays voltage-current characteristics are non linear, at one unique point the power produced is maximum. This point depends on the temperature of the solar panel and on the irradiance conditions. Both conditions change throughout the day and are also different depending on the seasons in the year. Further irradiation can vary rapidly due to changing atmospheric conditions like clouds. It is important to find the maximum power point precisely under all possible atmospheric conditions so that the maximum power can be obtained. To produce maximum power out of photovoltaic modules MPPT (Maximum power point tracking) system is used. MPPT is an electronic system which varies the electrical operating point of PV modules so that the PV modules are capable of delivering maximum available power.

Incremental Conductance was designed based on an observation of P-V characteristic curve as shown in fig 2.1 below. IC tries to improve the tracking time and to produce more energy on a vast irradiation changes environment. This method is based on the fact that slope of the PV array power curve is zero at the MPP, increasing on the left of the MPP and decreasing on the right hand side of MPP.

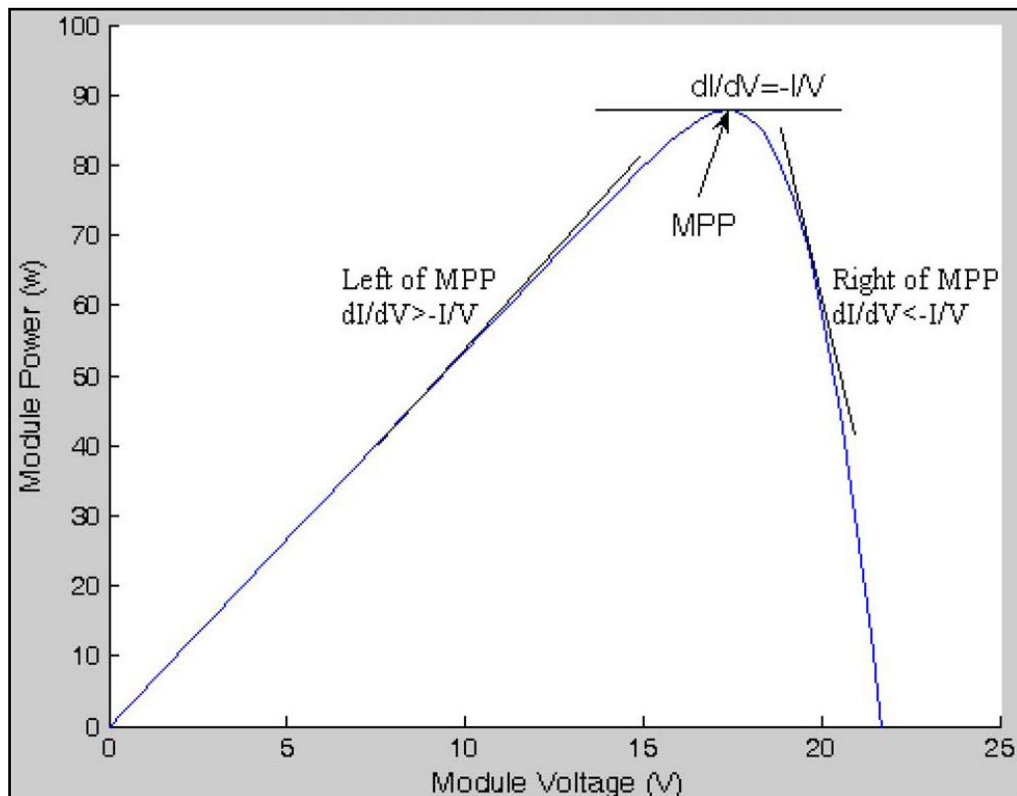

Fig2.1: PV curve of solar panel for Incremental conductance algorithm

International Journal of Innovative Research in Science, Engineering and Technology

(An ISO 3297: 2007 Certified Organization)

Website: www.ijirset.com

Vol. 6, Issue 6, June 2017

The flowchart of incremental conductance algorithm is shown in Fig2.2 below. The algorithm starts by taking present values of $I(k)$ and $V(k)$ and using previous values stored at the end of the prior cycle, $I(k-1)$ and $V(k-1)$, then verify whether the voltage variable is zero, if it is zero then verify whether the current variable equals zero. If the current variable is also zero, then it means that PV is operating at the maximum power point, so the conductance should remain same and there is no need to change duty cycle

Two other verifications are included to detect whether a control action is required when the array was not operating at the maximum power point; in this case the change in the atmospheric conditions is detected using ($dI \neq 0$). Now the control signal adjustment depend on whether dI is positive or negative, if the incremental change in current is positive, the duty cycle should be increased, otherwise it should be decreased.

On the other hand if there is a condition where the voltage variable is not zero, thus verification is carried out by comparing dI/dV with $-I/V$. According to the result of this verification, the control reference signal adjusted in such a way that array terminal voltage can be moved towards maximum power point voltage. At the maximum power point when dI/dV equal to $-I/V$, no control action is needed. If dI/dV is greater than $-I/V$ then duty cycle should be increased, otherwise it should be decreased.

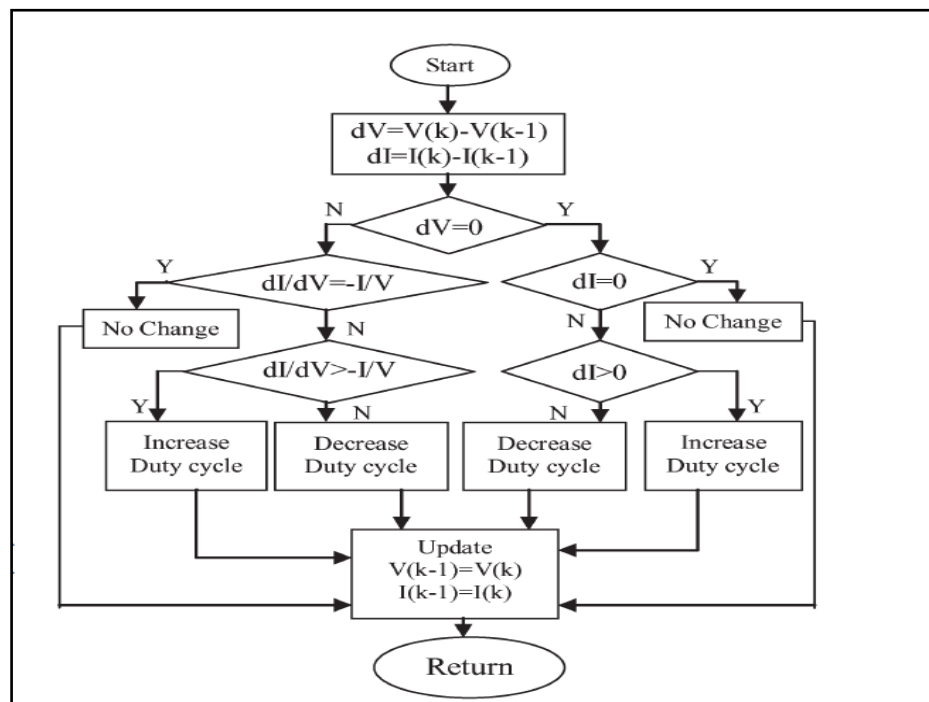

Fig 2.2: flowchart of incremental conductance algorithm

III. BLOCK DIAGRAM OF SOLAR PV FED DC MOTOR SPEED CONTROL SYSTEM

Fig3.1 below shows the block diagram of solar PV fed DC motor speed control using microcontroller based power electronic controller

International Journal of Innovative Research in Science, Engineering and Technology

(An ISO 3297: 2007 Certified Organization)

Website: www.ijirset.com

Vol. 6, Issue 6, June 2017

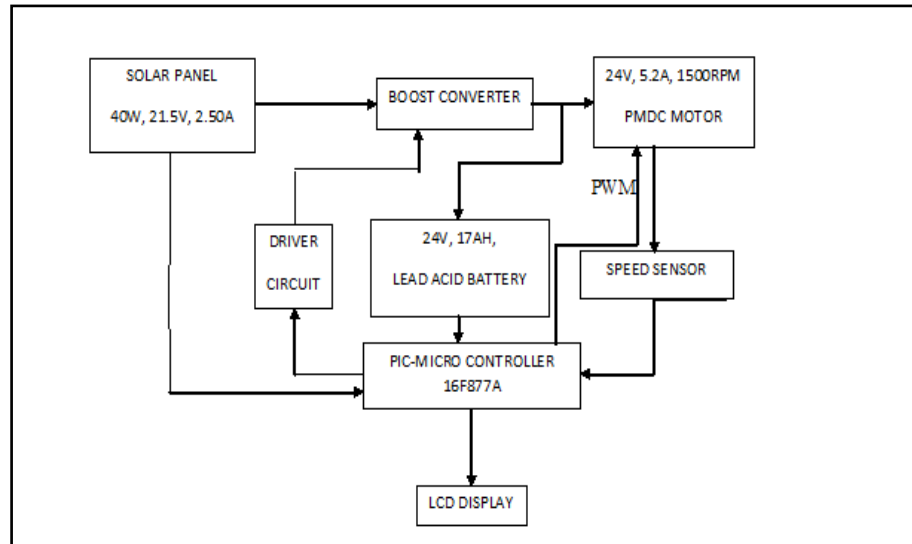

Fig 3.1: Block diagram of solar PV fed DC motor speed control system

Solar panel output is given to the boost converter, so that boost converter will boost the input DC voltage to 24V DC to charge the batteries. Now the battery output is given to PMDC motor. The duty cycle of boost converter is changed by using IC MPPT algorithm. The algorithm is written in the microcontroller programming. This MPPT will allow the maximum available solar power to the boost converter for battery charging purpose.

The PMDC Motor is connected to the DC drive. This DC drive is connected to the PIC microcontroller which is connected to the Diode-Transistor Optocoupler for speed sensing. The Optocoupler provides the rpm feedback to the controller. Controller compares the set speed with actual speed and produces the error signal. The PI controller will make this error zero by increasing or decreasing the voltage across the armature of motor. If the actual speed is greater than the set speed, the PI controller will decrease the firing angle of the MOSFET resulting in decrease in armature voltage. If actual speed is less than the set speed, then the PI controller will increase the firing angle resulting in increase in voltage across the armature, so that the desired set rpm can be achieved. The display shows set speed, actual speed, V_{slr} , I_{slr} , V_{batt} , I_{batt} . The firing angle of MOSFET is controlled by the driver circuit.

IV. SIMULATION AND RESULT OF SOLAR PV FED DC MOTOR SPEED CONTROL USING MICROCONTROLLER BASED POWER ELECTRONIC CONTROLLER

The simulation of solar PV fed DC motor speed control using microcontroller based power electronic controller using MATLAB/ Simulink is discussed in this section. Simulations are performed to see the effect of varying irradiation and temperature is assumed fixed at 25°C. The simulink diagram is shown in Fig 4.1 below:

International Journal of Innovative Research in Science, Engineering and Technology

(An ISO 3297: 2007 Certified Organization)

Website: www.ijirset.com

Vol. 6, Issue 6, June 2017

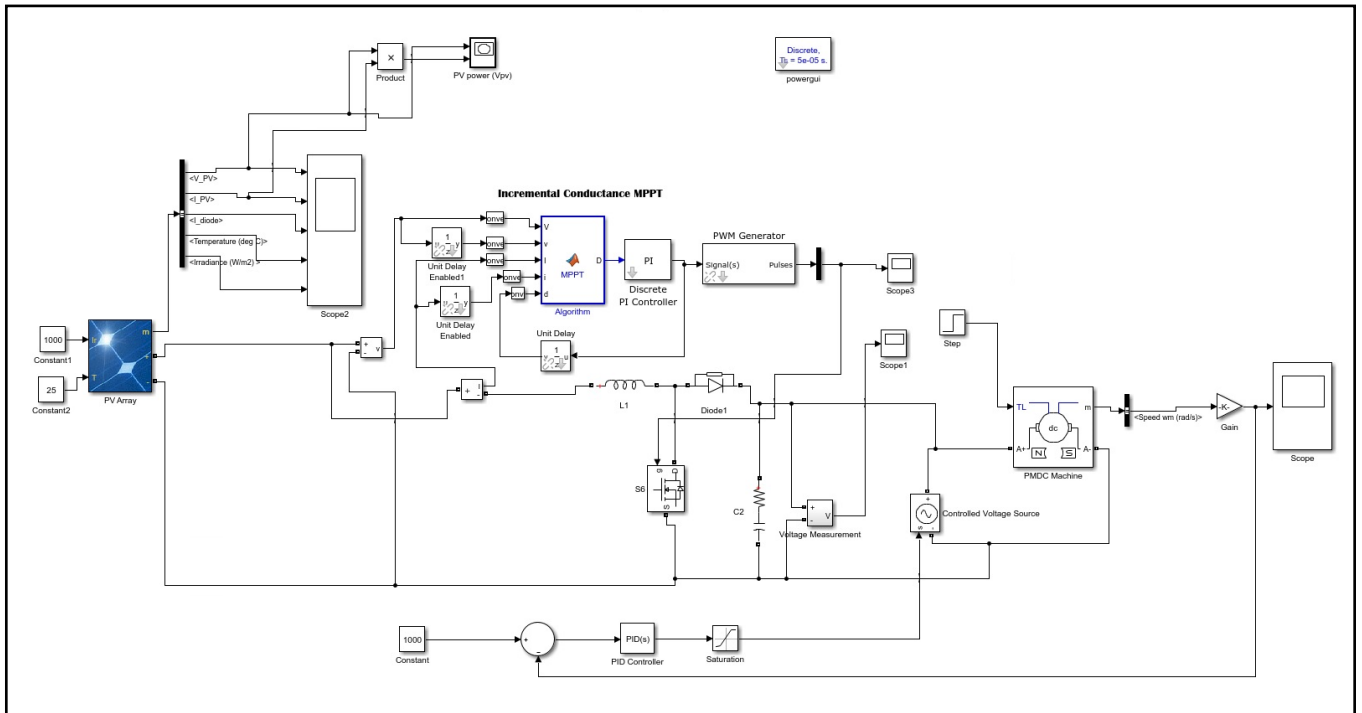

Fig 4.1: The Simulink diagram of solar PV fed DC motor speed control system

First irradiation 800W/m^2 is given to solar array, gives the boost output as 23.93V and duty cycle as 0.56, where on time of MOSFET is $493.085\mu\text{s}$. It is shown in fig 4.2 and fig 4.3 respectively.

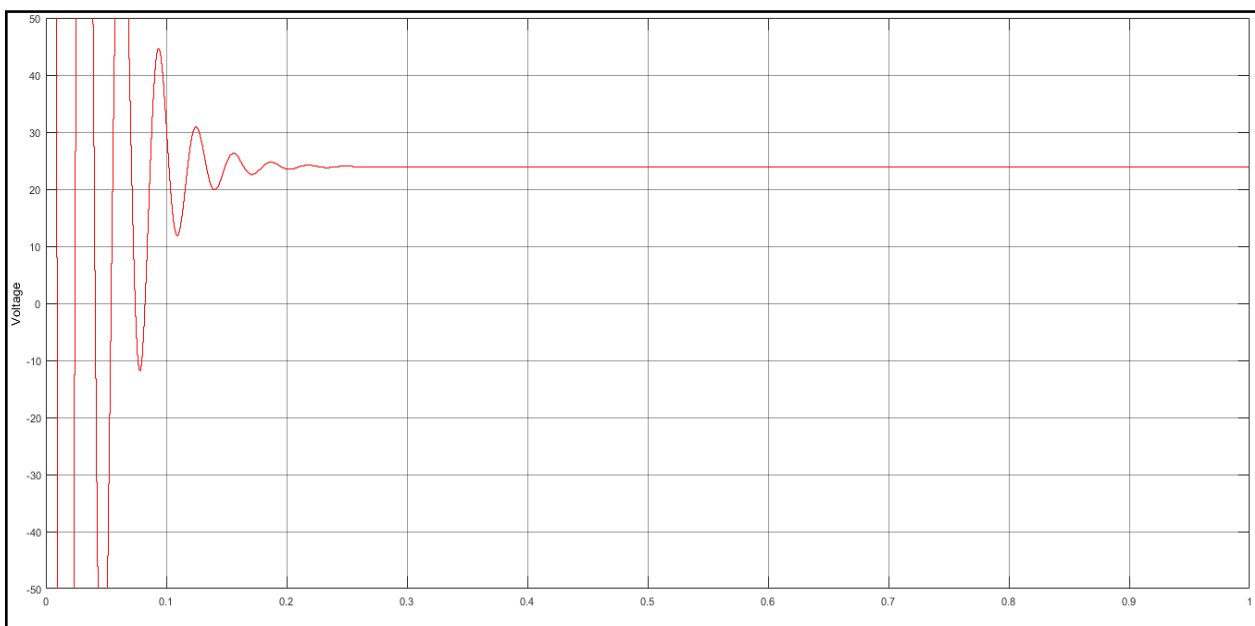

Fig 4.2: Boost converter output voltage when input solar irradiation is 800W/m^2

International Journal of Innovative Research in Science, Engineering and Technology

(An ISO 3297: 2007 Certified Organization)

Website: www.ijirset.com

Vol. 6, Issue 6, June 2017

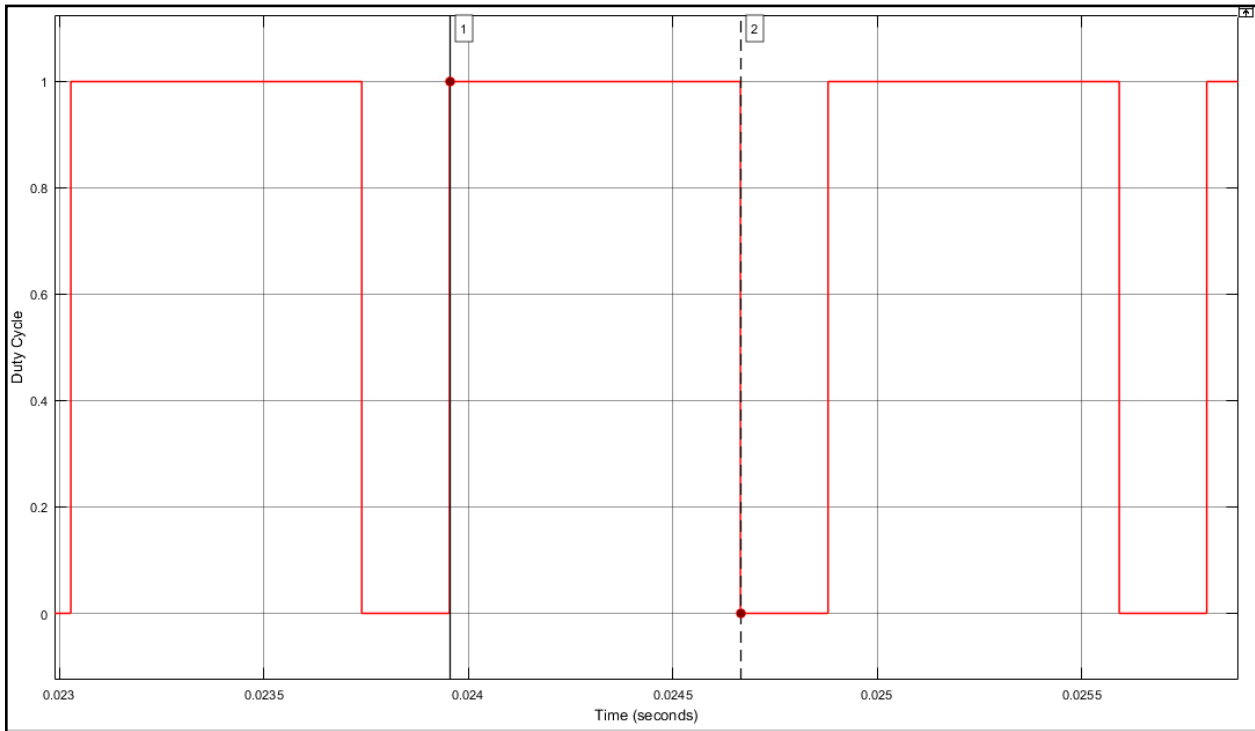

Fig 4.3: Duty cycle of boost converter when solar irradiation is 800 W/m^2

Then irradiation 1000 W/m^2 is given to solar array, gives the boost output constant as 23.93 V and duty cycle as 0.57 , where on time of MOSFET is $711.002 \mu\text{s}$. It is shown in Fig 4.4 and Fig 4.5 respectively

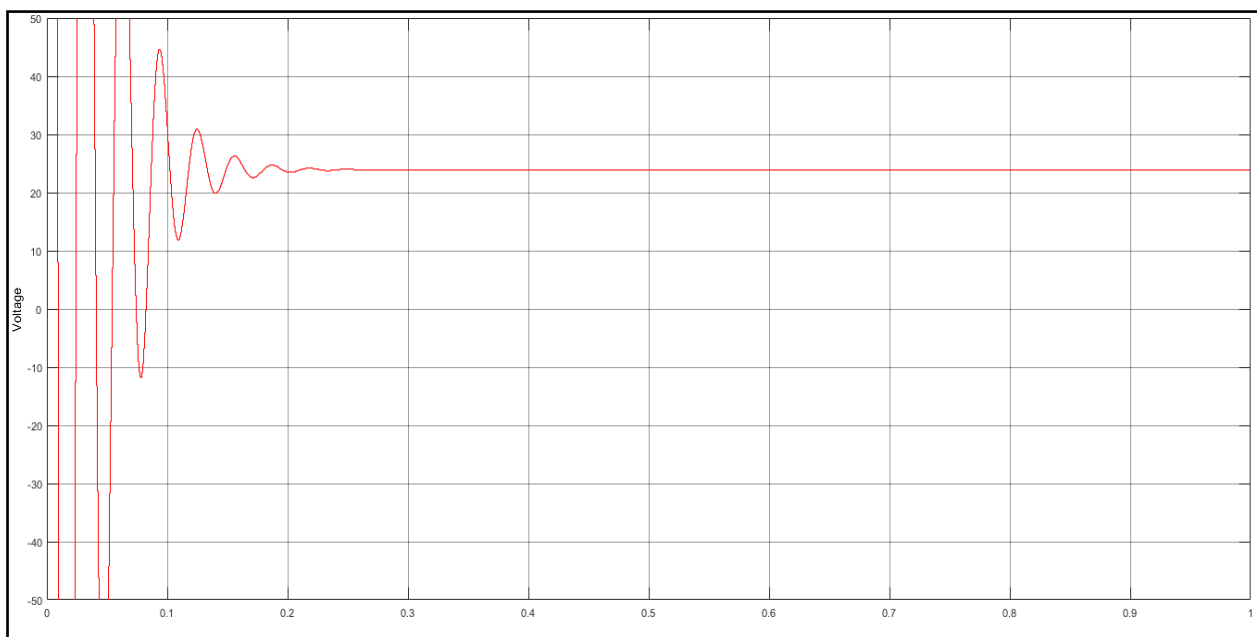

Fig 4.4: Boost converter output voltage when input solar irradiation is 1000 W/m^2

International Journal of Innovative Research in Science, Engineering and Technology

(An ISO 3297: 2007 Certified Organization)

Website: www.ijirset.com

Vol. 6, Issue 6, June 2017

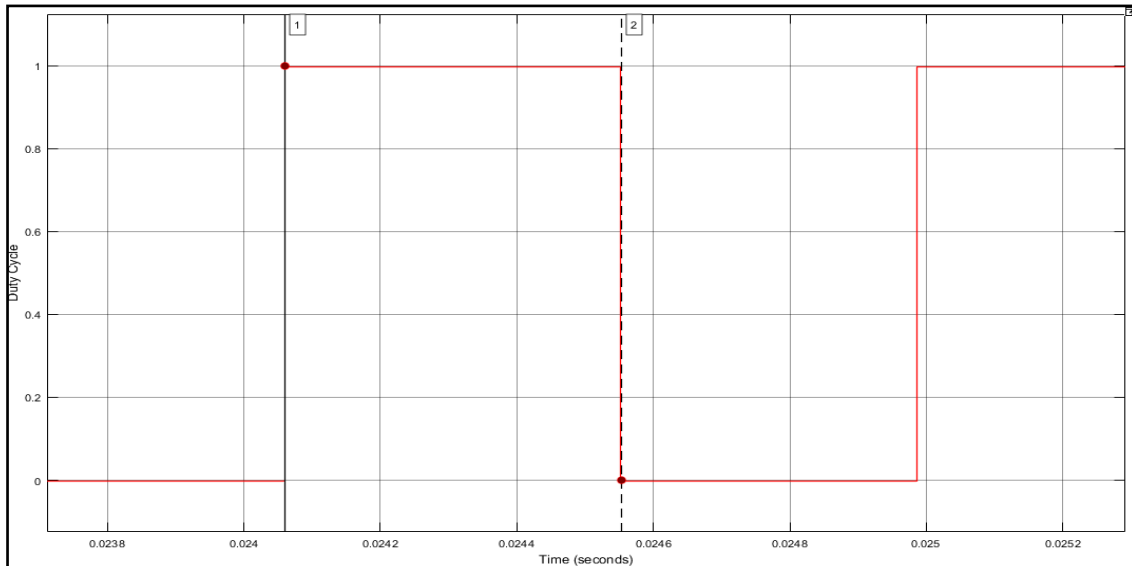

Fig 4.5: Duty cycle of boost converter when solar irradiation is 1000 W/m^2

From above simulation results it is clear that Incremental conductance algorithm adjusts the boost converter duty cycle as the solar irradiation changes to give constant 24V DC to charge the battery. Also duty cycle is increased as solar irradiation increases from 800 W/m^2 to 1000 W/m^2

V. HARDWARE IMPLEMENTATION AND RESULTS OF SOLAR PV FED DC MOTOR SPEED CONTROL SYSTEM

This section discusses about hardware implementation and its results. The circuit diagram of hardware setup for solar PV fed DC motor speed control is shown in Fig 5.1 below. The hardware makes use of Solar panel, boost converter, battery, PIC 16F877A microcontroller, speed sensor and MOSFET for speed control of PMDC motor using electronic armature voltage control method. The display shows set speed, actual speed, V_{slr} , I_{slr} , V_{batt} , I_{batt} . The firing angle of MOSFET is controlled by the driver circuit. The hardware set up is shown in fig 5.2

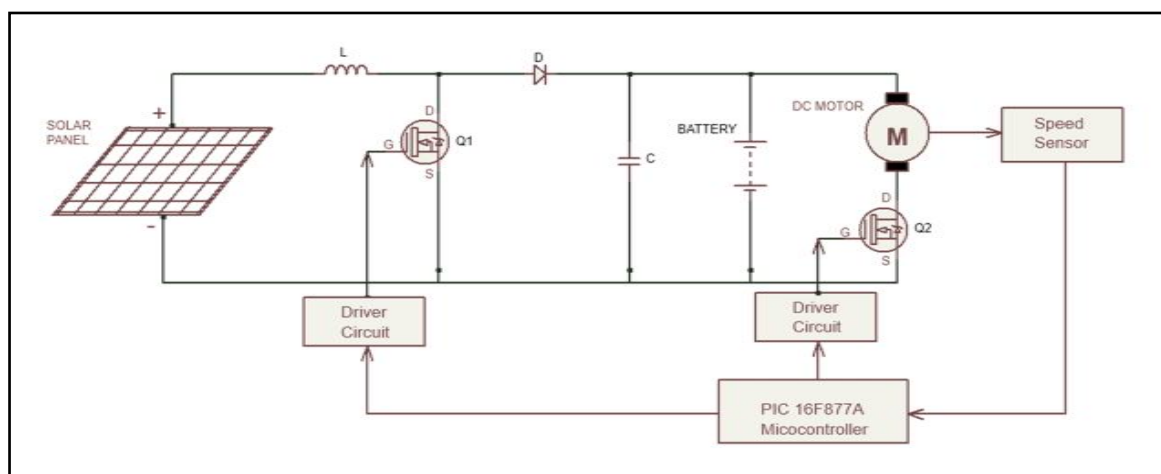

Fig 5.1: Circuit Diagram of solar PV fed DC motor speed control system

International Journal of Innovative Research in Science, Engineering and Technology

(An ISO 3297: 2007 Certified Organization)

Website: www.ijirset.com

Vol. 6, Issue 6, June 2017



Fig 5.2: Hardware set up for solar PV fed DC motor speed control using microcontroller based power electronic controller

A procedural detail of hardware working is as follows:

- Set speed and values of proportional and integral constant is fed in to the PIC through its programming. We can set the values of speed and values of proportional and integral constant by using INC (increment) and DEC (decrement) keys.
- Once these values fed into the PIC16F877A, solar panel output is given to the battery through boost converter as well as motor. During day period, when sunlight is available, PV output will charge the battery as well as feeds the motor. During the night period, solar panel and boost converter are isolated from circuit and battery will feeds the motor.
- Incremental conductance MPPT is used to optimize the solar panel output power. Its algorithm is written in PIC microcontroller programming. According to this algorithm, duty cycle of boost converter is modified through driver circuit.
- Boost converter will boost the I/P solar voltage from 17-17.5V to 28V and thus charges the battery. The MOSFET is used to control the supply voltage to the motor. The speed of the motor is sensed by the speed sensor i.e. Diode Transistor optocoupler. A rectangular bar is attached to the shaft of the motor. As the bar passes through the optocoupler, the signal pulse is generated which is given as a feedback to the PIC16F877A.
- The controller compares the set speed with actual speed and generates the error signal. The error is then minimized by the PI action of controller and accordingly the output is given to the driver circuit of MOSFET. Thus the MOSFET get fired and by controlling its on time, off time; the voltage applied to motor armature is controlled to get desired value of speed.

The experimental observations of the battery charging are as follows:

Time	Vslr (V)	Vboost (V)	Islr (A)	Iboost (A)	D
7.30AM	17.2	23	0.02	0.13	0.049
8.30AM	17.2	23.4	0.28	0.14	0.287
9.30AM	17.3	23.5	0.54	0.24	0.316
10.30AM	17.3	23.6	0.69	0.34	0.319
11.30AM	17.1	23.6	0.75	0.39	0.319
12.30PM	17.1	23.6	0.85	0.44	0.319
01.30PM	17.1	23.7	0.95	0.50	0.326
02.30PM	17.2	23.7	1.04	0.55	0.325

Table5.1: Experimental observations of battery charging

International Journal of Innovative Research in Science, Engineering and Technology

(An ISO 3297: 2007 Certified Organization)

Website: www.ijirset.com

Vol. 6, Issue 6, June 2017

Below DSO screenshots shows the duty cycle waveforms of boost converter at different times of a day.

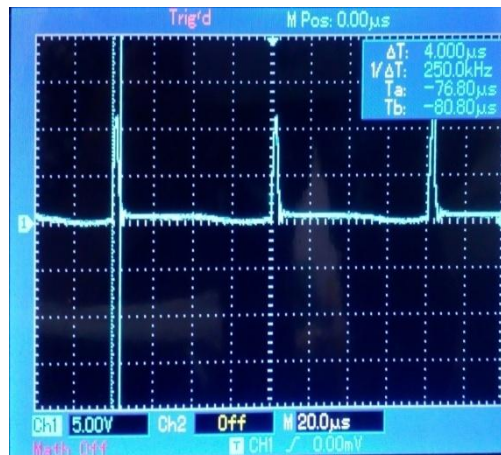

Fig 5.3: Duty cycle of boost converter at time 7.30AM

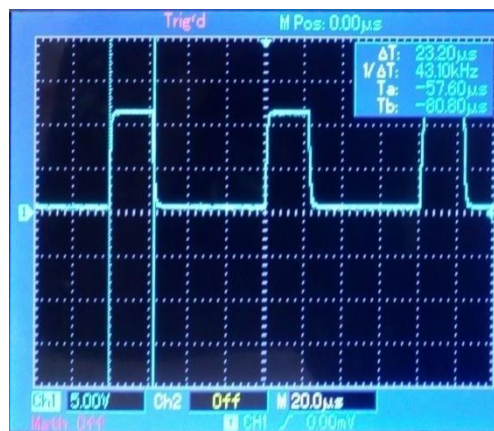

Fig 5.4: Duty cycle of boost converter at time 8.30AM

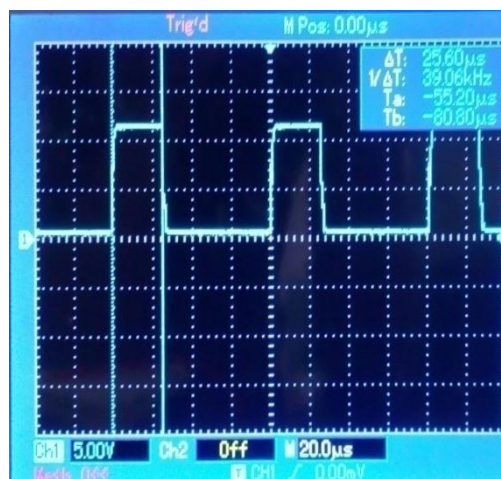

Fig 5.5: Duty cycle of boost converter at time 9.30AM

International Journal of Innovative Research in Science, Engineering and Technology

(An ISO 3297: 2007 Certified Organization)

Website: www.ijirset.com

Vol. 6, Issue 6, June 2017

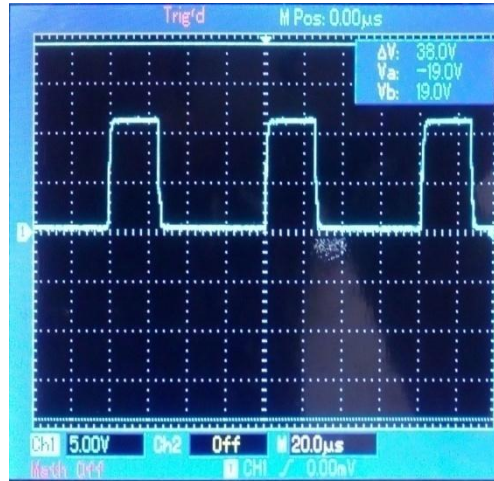

Fig 5.6: Duty cycle of boost converter at time 1.30PM

The experimental observations of the speed control are as follows:

The values of K_p and K_i selected are: $K_p=0.5$

$K_i=0.25$

The motor is tested for different values of set speed as shown in Table 5.2 below. The input voltage to motor is varied and corresponding speed of motor is noted down after PI action. The motor is tested under no load condition.

Set RPM	Actual RPM	DC Voltage across armature	DC battery voltage applied
600	630	3.9	22.28
700	720	4.55	20.22
800	840	5.50	24.44
900	880	5.86	23.44
1000	990	6.18	22.47
1100	1170	7.44	24.8
1200	1230	7.42	24.73

Table 5.2: Experimental results of speed control of motor on no load

VI. CONCLUSION

In this paper an attempt is made to design and fabricate IC MPPT algorithm using PIC microcontroller for PV array, so that it will extract maximum available solar power used for charging the battery. Incremental conductance MPPT using direct control method is used in such a way that duty cycle of boost converter is adjusted inside the algorithm. Thus, there is no need to use any other control loop. The proposed MPPT method and speed control technique is investigated through simulations and validated experimentally on a laboratory prototype.

VII. FUTURE SCOPE

1. A fuzzy logic control (FLC) can be used to control the maximum power point tracking (MPPT) for a photovoltaic (PV) system.
2. Tachogenerator can be employed in place of Diode Transistor optocoupler to increase the accuracy of speed feedback.
3. A PID controller can be used for controlling the speed of the motor.

International Journal of Innovative Research in Science, Engineering and Technology

(An ISO 3297: 2007 Certified Organization)

Website: www.ijirset.com

Vol. 6, Issue 6, June 2017

REFERENCES

1. HabbatiBellia, Ramdani Youcef, Moulay Fatima, "A detailed modeling of photovoltaic module using MATLAB," NRIAG Journal of Astronomy and Geophysics (2014) 3, 53–61
2. A Safari, S. Mekhilef, "Implementation of Incremental Conductance method with Direct Control," TENCON 2011, 2011 IEEE
3. RatnalkaPutria, Sapto Wibowob, Muhamad Rifa, "Maximum power point tracking for photovoltaic using incremental conductance method," 2nd International Conference on Sustainable Energy Engineering and Application, ICSEEA 2014
4. M.Lokanadham,K.VijayaBhaskar, "Incremental Conductance Based Maximum Power Point Tracking (MPPT) for Photovoltaic System," International Journal of Engineering Research and Applications (IJERA) Vol. 2, Issue 2, Mar-Apr 2012
5. Aleck W. Leedy, LipingGuo, Kennedy A. Aganah, "A Constant Voltage MPPT Method for a Solar Powered Boost Converter with DC Motor Load," 2nd International Conference on Sustainable Energy Engineering and Application, ICSEEA 2014
6. PongsakorTakun, SomyotKaitwanidvilai, ChaiyanJettanasen, "Maximum Power Point Tracking using Fuzzy Logic Control for Photovoltaic Systems," Proceedings of the International MultiConference of Engineers And Computer Scientists 2011 Vol II, IMECS 2011, March 16- 18, 2011, Hong Kong
7. Lalam S. Sindhura, KalpanaChaudhary, "Artificial Neural Network Implementation for Maximum Power Point Tracking of Optimized Solar Panel," International Journal of Computer Applications (0975–8887) Volume 78–No.10, September 2013
8. S.Krithiga, N.AmmasaiGounden, "A Microcontroller based Power Electronic Controller for PV assisted DC motor Control," 2013 6th International Conference on Industrial and Information Systems, ICIIS 2013, Aug. 16-19, 2013, Sri Lanka
9. Aruna. K, Pravin. M. R, Ramachandran. J, Sudheer. S ,Sathiyasekar. K , "Design and Implementation of PI Controller for the Speed Control of DC Motor in Cooling System," International Journal of Engineering Trends and Technology (IJETT)– Volume 9 Number 5 - Mar 2014
10. RupaliNazar, "Improvement of Efficiency of Solar Panel using different methods," International Journal of Electrical and Electronics Engineers, Volume 07, Issue 01, Jan- June 2015
11. <http://www.autospectator.com/cars/files/images/Photovoltaic-Cell.jpg>
12. http://en.wikipedia.org/wiki/Photovoltaic_array
13. Theodore Wildi, "Electrical Machines Drives, and Power Systems," Prentice Hall, Ohio, 2006.