

Self-Coherent OFDM with Undersampling Down-Conversion for Wireless Communication

Abbas Kadri¹, Dr. Mukund Wani²

^{1,2}Department of Electronics and Telecommunication Engineering, Dr. D.Y. Patil School of Engineering & Technology, Charholi Budruk Lohegaon, Pune, India.

ABSTRACT: OFDM is a frequency-division multiplexing (FDM) plot utilized as a digital multi-carrier modulation strategy. OFDM has formed into a well-known plan for wideband digital communication, utilized in applications such as digital television and audio broadcasting, DSL Internet access, wireless networks, power line networks, and 4G mobile communications. OFDM is a frequency-division multiplexing (FDM) scheme utilized as a digital multi-carrier modulation technique. A large number of closely spaced orthogonal sub-carrier signals are utilized to convey information on a few parallel information streams or channels. Each sub-carrier is modulated with a conventional modulation scheme (such as quadrature amplitude modulation or phase-shift keying) at a low symbol rate, keeping up aggregate information rates similar to conventional single-carrier modulation schemes in the same bandwidth. We adopt a under sampling down-conversion strategy in conjunction with self-intelligible OFDM. We demonstrate that with the self-intelligent demodulation, the extra PN presented by under inspecting down-change can be essentially lessened. We think about diagnostically the framework execution of self-coherent OFDM utilizing under sampling down-conversion with two other conventional OFDM frameworks: one with super-heterodyne recipient and the other with under sampling down-conversion. We demonstrate theoretically and by simulations that both in AWGN and frequency selective fading channels, self-coherent OFDM with under sampling down conversion outperforms the two conventional OFDM frameworks notwithstanding when intermarried interference (ICI) compensation schemes are applied.

KEYWORDS: non-coherent, OFDM, self-coherent, phase noise, multipath fading, low-complexity receivers, under sampling down conversion.

I. INTRODUCTION

An extensive number of firmly dispersed orthogonal sub-transporter signals are used to pass on information [1] on a couple of parallel data streams or channels. Each sub-transporter is tweaked with an ordinary adjustment design, (for instance, quadrature sufficiency regulation or stage move scratching) at a low image rate, keeping up total data rates like customary single-bearer balance plots in a similar transmission capacity. The basic great position of OFDM over single-transporter designs is its ability to adjust to genuine channel conditions (for instance, constriction of high frequencies in a long copper wire, narrowband impedance and recurrence specific blurring due to multipath) without complex leveling channels. Channel balance is rearranged on the grounds that OFDM may be viewed as using many step by step adjusted narrowband flags instead of one quickly regulated wideband flag. The low picture rate makes the use of a monitor interim between images reasonable, making it conceivable to wipe out intersymbol impedance (ISI) and utilize echoes and time-spreading (on simple TV these are noticeable as ghosting and obscuring, separately) to accomplish an assorted qualities pick up, i.e. a flag to-clamor proportion change. This segment in like manner energizes the arrangement of single recurrence systems (SFNs), where a couple of adjacent transmitters send a comparable flag

International Journal of Innovative Research in Science, Engineering and Technology

(An ISO 3297: 2007 Certified Organization)

Website: www.ijirset.com

Vol. 6, Issue 6, June 2017

all the while at a similar recurrence, as the signs from different far off transmitters might be consolidated productively, as opposed to meddling as would normally happen in a conventional single-transporter structure.

II. METHODOLOGY

Orthogonal frequency division multiplexing (OFDM) is a well-known strategy that brings the benefits of high spectral efficiency, strength to intersymbol obstruction, straightforward channel adjustment and proficient execution utilizing Fast Fourier Transform (FFT). It is realized that the intermarried interference (ICI) is a major issue in customary OFDM because of Doppler frequency drift, phase offset, local oscillator frequency drift, and sampling clock offset. For high frequencies, utilized as a part of millimeter-wave and terahertz communications, high level residual phase noise (PN) because of hazards of oscillators and blenders of the coherent reception can be severe. Hence, new OFDM strategies that are strong to ICI and equipped with low complexity transceiver structures are needed to implement millimeter-wave wireless communication.

IV. LITERATURE SURVEY

Qianyu Jin et. al. [1] “Self-Coherent OFDM for Wireless Communications” In this paper, we introduce self-reasonable OFDM, a well-known non-coherent strategy in optical communications, for wireless RF communications. utilizing a straightforward RF front-end receiver and to provide a significantly higher spectral efficiency than self-het OFDM, which utilizes at most 50% of the available spectrum for communications. we show the execution investigation of self-cognizant OFDM over additive white Gaussian noise (AWGN) and frequency selective fading channels. We introduce the execution investigation of self-coherent OFDM over AWGN and frequency selective fading channels. We demonstrate that self-coherent OFDM achieves better spectral efficiency and BER execution than self- het OFDM; and preferable BER execution over conventional OFDM when phase noise presents.

Nirmal Fernando et. al. [2] “Self-Heterodyne OFDM Transmission for Frequency Selective Channels” Self-heterodyne OFDM (self-het OFDM) is known to provide complete immunity against frequency-offset and phase noise, with a much lower RF frontend complexity, when contrasted with routine OFDM procedures. Self-het OFDM is considered to be a promising physical layer innovation for millimeter-wave RF communications, where the usage of low complexity stable oscillators is technically difficult. Although self-het OFDM has awesome potential, it has just been considered for added substance white Gaussian noise and two-ray channel models. In this paper, we consider an and break down the execution of self-het OFDM over frequency selective channels. We find that the standard self-het OFDM undergoes an outage if the local carrier signals experiences deep fading. This outcomes in a huge execution misfortune (diversity order less than one), when compared to conventional OFDM with super-heterodyne structures.

S. Adhikari et. al. [3] “ Self- Coherent Optical OFDM: An Interesting Alternative to Direct or Coherent Detection ” Recently, coherent optical orthogonal frequency division multiplexing (CO-OFDM) has been considered for the next generation 400-Gb/s whole deal information transmission. For whole deal transmission frameworks intelligible location is helpful compared to direct detection as it provides higher sensitivity. In this paper, we have looked onto different possible methods for accomplishing self-coherent optical detection. We have delved in deeper into self coherent detection with IQ demultiplexing with the utilization of FP-TF for extricating the optical transporter. Due to its high Q-value, the bandwidth of the guardband between the carrier and OFDM signal can be relaxed.

Robert C et. al. [4] “60 GHz Wireless Communications: Emerging Requirements and Design Recommendations” Various GHz of universally accessible, unlicensed spectrum surrounding the 60 GHz carrier frequency has the ability to accommodate high-throughput wireless communications. While the size and availability of this free spectrum make it very attractive for wireless applications, 60 GHz implementations must overcome many difficulties. For example, the high attenuation and directional nature of the 60 GHz wireless channel as well as constrained pick up enhancers and extreme stage noise in 60 GHz transceivers are express usage challenges. The extensive amount of unlicensed

International Journal of Innovative Research in Science, Engineering and Technology

(An ISO 3297: 2007 Certified Organization)

Website: www.ijirset.com

Vol. 6, Issue 6, June 2017

bandwidth internationally available at 60 GHz provides framework architects with a large number of alternatives for remote communications application.

Changhua Cao et. al. [5] "Millimeter-Wave Voltage-Controlled Oscillators in 0.13-microm CMOS Technology" This paper depicts the plan of CMOS millimeter-wave voltage controlled oscillators. Varactor, transistor, and inductor outlines are upgraded to lessen the parasitic capacitances. Millimeter-wave VCOs working close to 60 and 100 GHz are exhibited. Decreasing the metal parasitic capacitances of varactors, inductor and transistors is the key for accomplishing the wide tuning range (6 GHz) at 60 GHz and operation close to 100 GHz utilizing a mass CMOS handle.

Tetsuya Miyazaki et. al. [6] "PSK Self-Homodyne Detection Using a Pilot Carrier for Multibit/Symbol Transmission With Inverse-RZ Signal" Phase-shift-keying (PSK) self-homodyne modulation and demodulation utilizing a polarization-multiplexed pilot-carrier with an inverse-return-to-zero (RZ) intensity modulation signal for 2-bit/symbol transmission at 20 Gb/s was illustrated. PSK homodyne detection utilizing a pilot carrier created at the transmitter side and an integrated pilot-carrier polarization rotator at the receiver side was shown in 2-bit/image operation with a backwards RZ motion at 20 GB/s. This is because of the way of homodyne detection using a balanced receiver to decrease intensity noise. Although automatic polarization control is required in the receiver side for fiber transmission experiments, the proposed pilot-carrier homodyne scheme is expected to offer a basic arrangement in transmission frameworks with a higher number of bits per symbol.

Ryan Aet. al. [7] "BER ANALYSIS OF SELF-HETERODYNE OFDM TRANSMISSION SCHEM" A self-heterodyne framework is power inefficient compared to a conventional coherent framework, yet it has the preferred standpoint that basic, low-cost, receivers can be built that are completely immune to any phase noise or frequency offset contributed by the transmitter's RF carrier: This is of particular significance to multicarrier plans, for example, OFDM, that are a great deal more sensitive to frequency and phase errors than single-carrier schemes. The target of this paper is to examine the execution of self heterodyne recipients expecting OFDM is the modulation scheme. This paper analyzed the probability of bit error performance of the self-heterodyne receiver assuming OFDM is the chosen modulation scheme. It was proven that self-heterodyne receivers are approximately 5dB worse than coherent receivers in AWGN channels.

YozoShoji et. al. [8] "60 GHz Band 64QAM/OFDM Terrestrial Digital Broadcasting Signal Transmission by Using Millimeter-Wave Self-Heterodyne System" This paper describes the first time experimental studies on 60-GHz band transmissions of terrestrial digital broad-casting signals (ISDB-T) with 64-QAM modulations on coded orthogonal frequency division multiplexing (COFDM) format. It has been an exceptionally troublesome analysis to achieve on the grounds that it requires exceptionally steady and low stage commotion oscillators in the millimeter-wave band. We prevail with regards to transmitting a 64-half quart QAM/OFDM digital terrestrial broadcasting (ISDB-T) signal in the 60-GHz frequency band by using our proposed millimeter-wave self-heterodyne framework. We exhibited that utilizing the proposed framework overcomes the problems of phase noise and frequency offset resulting from the millimeter-wave transmission link.

Miguel Calvoet. al. [9] "Phase Noise and Sub-Carrier Spacing Effects on the Performance of an OFDM Communication System" This letter analyzes the phase noise effects on an orthogonal frequency division multiplexing (OFDM) signal and its dependence with the sub-carrier spacing. Pilot-based channel estimation, which has been suggested as a means of combating the channel effects, can also correct the phase noise effects under some circumstances, which are investigated. OFDM has been proposed and is being tested for the dTTb with the aim of combating multipath and making an efficient utilization of the available bandwidth. Pilot-based channel estimation has been suggested as a means of combating the channel impacts. This procedure can likewise rectify the stage noise effects under some circumstances, as we have seen.

V. PROPOSED SYSTEM

A. Self-coherent OFDM over AWGN Channels A block diagram of a self-coherent OFDM communications system is shown in Fig. 1(a), where B_g is the frequency gap between the RF carrier and the first OFDM subcarrier, and B_s is the bandwidth of the effective OFDM subcarriers. Different from self-coherent OFDM we can have $B_g \leq B_s$. However, B_g should be large enough to accommodate the filter transition bands. Let $\Delta f = 1/T$ represent the subcarrier spacing, T the symbol period, $N_g = B_g/\Delta f$ be the number of guardband subcarriers, $N_s = B_s/\Delta f$ denote the number of OFDM subcarriers used to encode information. Let $N = N_s + N_g$ be the size of Fast Fourier Transform (FFT), f_c be the RF carrier frequency, and T_s be the sampling clock period at the receiver. At the transmitter, information bits are first mapped into QAM symbols X_k , $k = N_g, \dots, N-1$ and located over the last N_s OFDM subcarriers, while the remaining N_g OFDM subcarriers are set to zero. Through IFFT, parallel-to-serial conversion, addition of cyclic prefix (CP), digital-to-analogue conversion (DAC), and up-conversion, the time-domain OFDM symbol without CP.

B. Self-Coherent OFDM over Frequency Selective Channels Let $h(t)$ be the frequency selective channel impulse response. Using the same settings as above, the received signal $r(t)$ is given by $r(t) = h(t) * x(t) + n(t)$, where $x(t)$ is given in (1). The PSD of $r(t)$ is represented by $G_r(f)$ which is given by $G_r(f) = \Lambda(f_c) + |H(f)|^2 G_s(f) + G_n(f)$, where $H(f)$ denotes channel response.

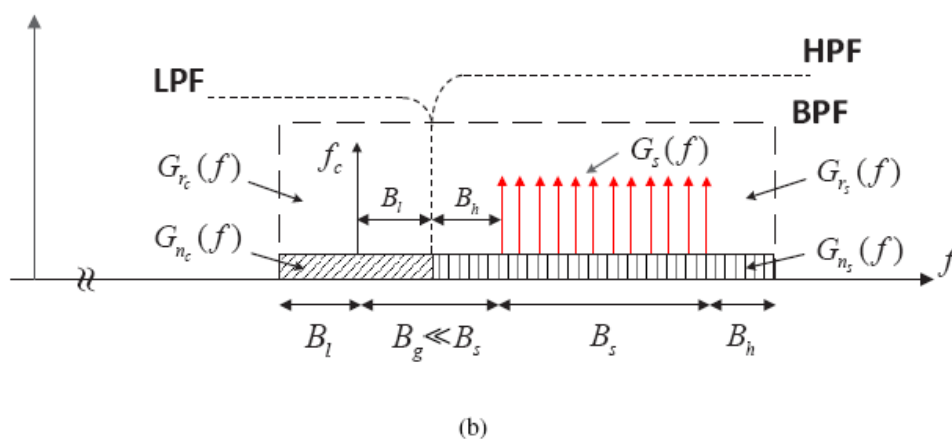
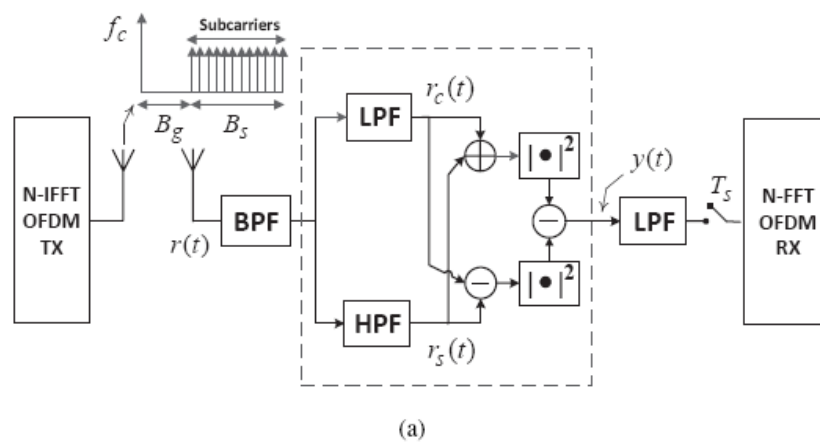

International Journal of Innovative Research in Science, Engineering and Technology

(An ISO 3297: 2007 Certified Organization)

Website: www.ijirset.com

Vol. 6, Issue 6, June 2017

VI. EXPERIMENTAL RESULT

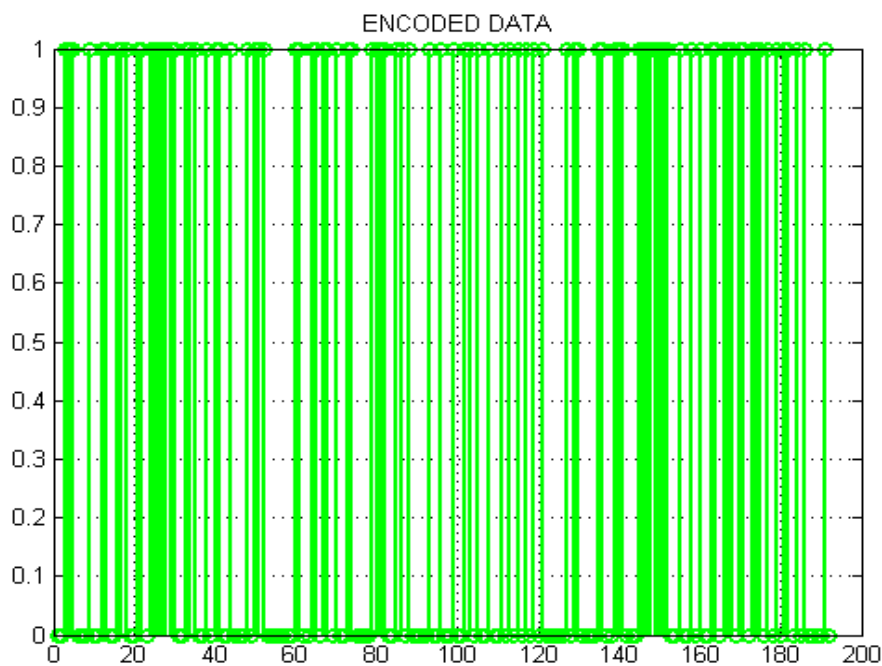
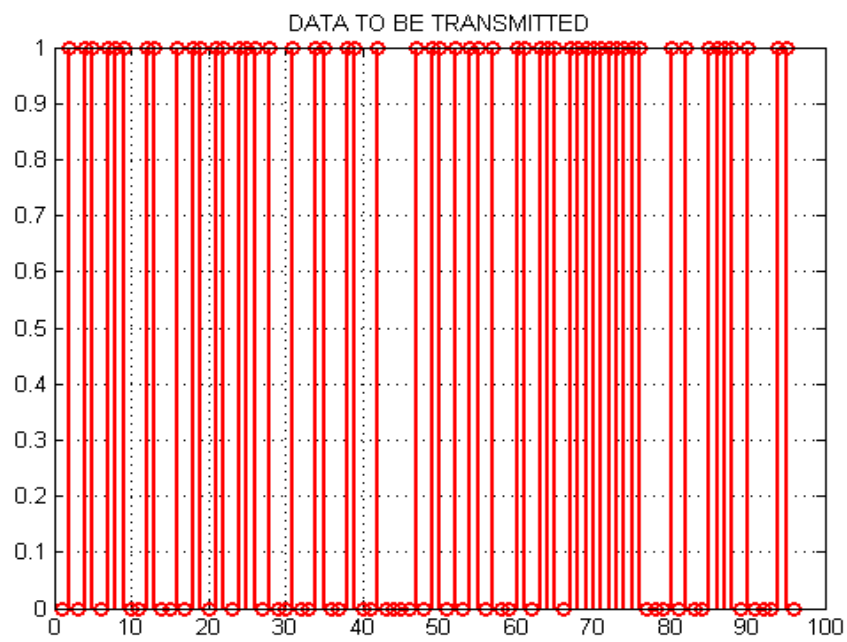

International Journal of Innovative Research in Science, Engineering and Technology

(An ISO 3297: 2007 Certified Organization)

Website: www.ijirset.com

Vol. 6, Issue 6, June 2017

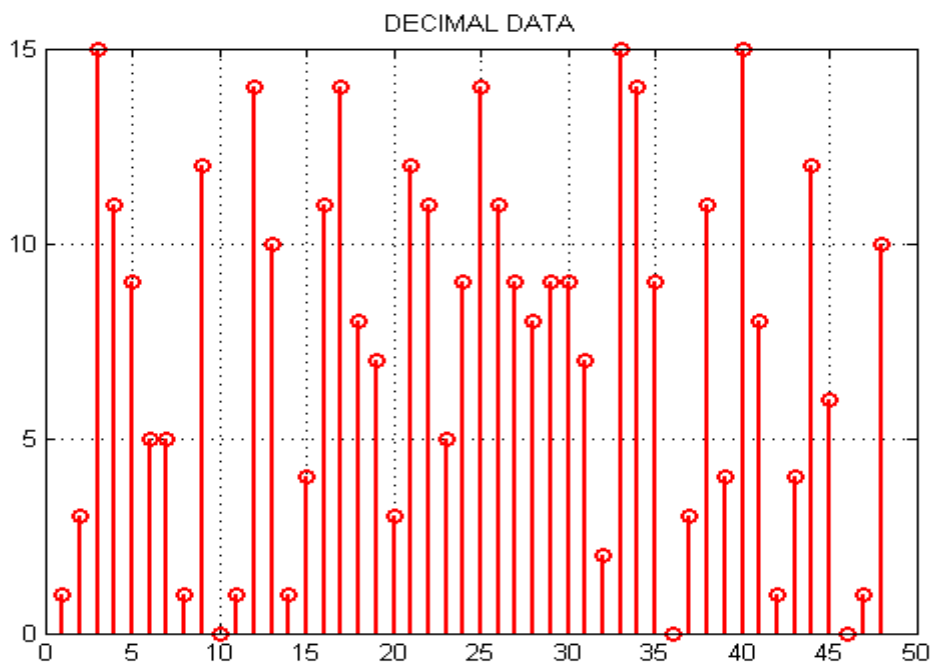
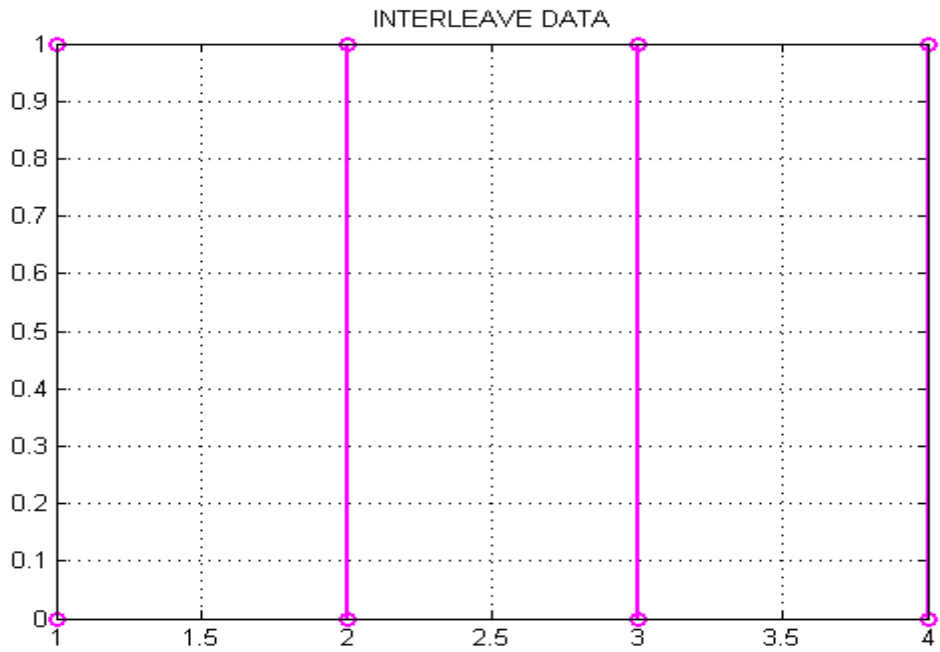

International Journal of Innovative Research in Science, Engineering and Technology

(An ISO 3297: 2007 Certified Organization)

Website: www.ijirset.com

Vol. 6, Issue 6, June 2017

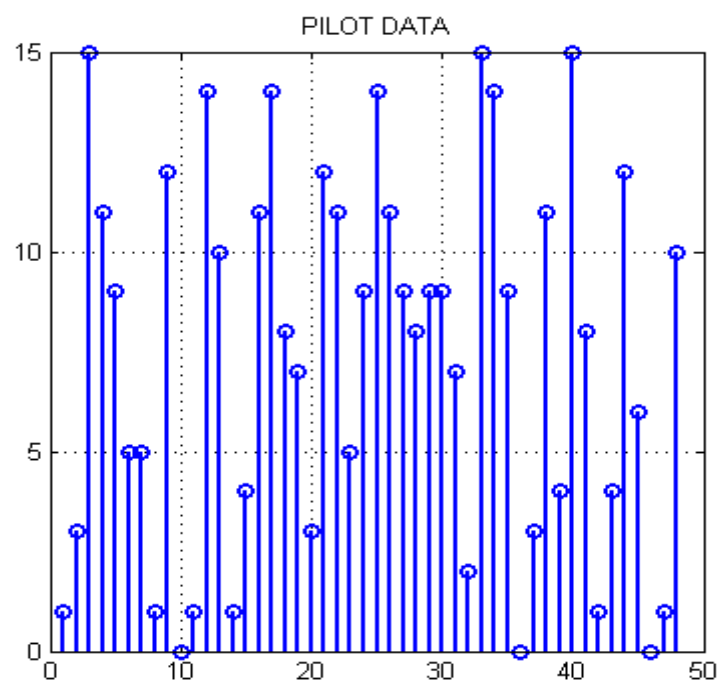
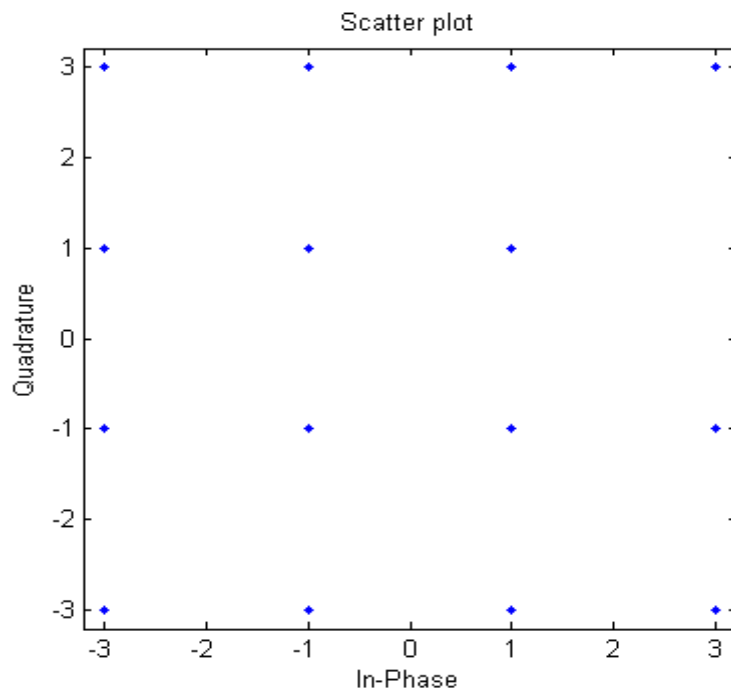

International Journal of Innovative Research in Science, Engineering and Technology

(An ISO 3297: 2007 Certified Organization)

Website: www.ijirset.com

Vol. 6, Issue 6, June 2017

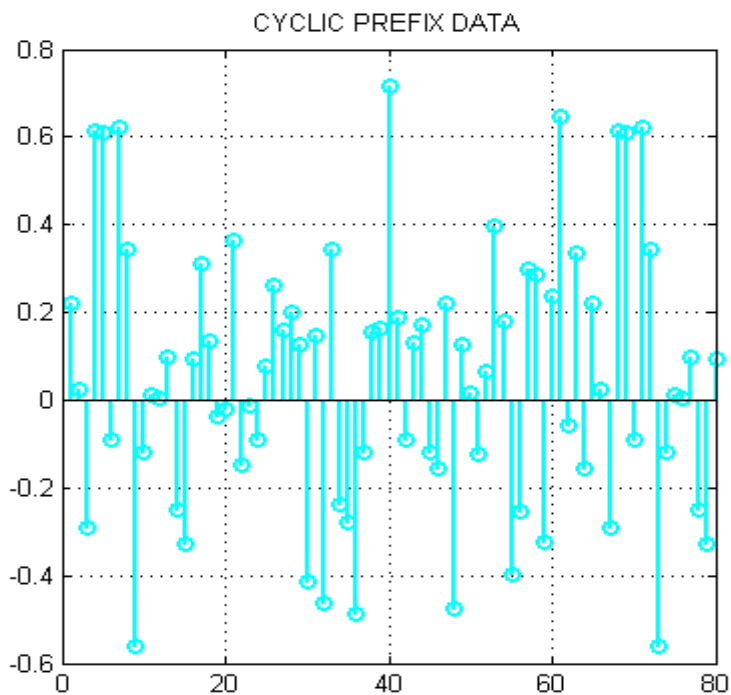
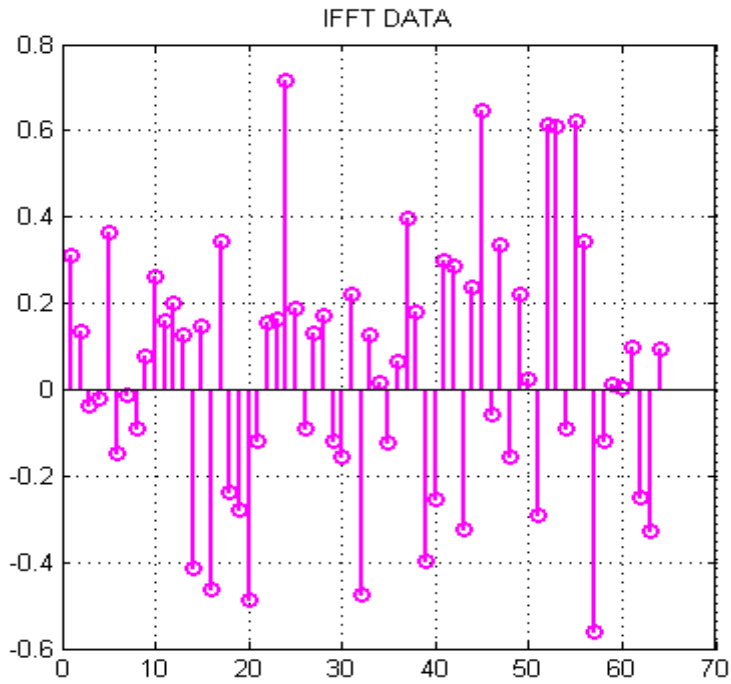

International Journal of Innovative Research in Science, Engineering and Technology

(An ISO 3297: 2007 Certified Organization)

Website: www.ijirset.com

Vol. 6, Issue 6, June 2017

VI. CONCLUSION

We have adapted the self-coherent OFDM strategy, initially utilized in optical communications, to wireless communication frameworks. We have analyzed its performance in terms of BER over AWGN and frequency selective fading channels. We have found that self-coherent OFDM accomplishes better ghostly proficiency and BER execution than self-het OFDM.

REFERENCES

- [1] Q. Jin, Y. Hong and E. Viterbo, "Self-coherent OFDM for wireless communications," 2015 IEEE International Conference on Communications (ICC), pp. 4303-4308, London, June 2015.
- [2] N. Fernando, Y. Hong, and E. Viterbo, "Self-heterodyne OFDM transmission for frequency selective channels," IEEE Transactions on Communications, vol. 61, no. 5, pp. 1936-1946, May 2013.
- [3] S. Adhikari, S.L. Jansen, M. Alfiad, B. Inan, V.A.J.M. Sleiffer, A. Lo-bato, P. Leoni, and W. Rosenkranz, "Self-coherent optical OFDM: an interesting alternative to direct or coherent detection," 13th IEEE International Conference on Transparent Optical Networks (ICTON), pp. 1-4, Stockholm, Sweden, June 2011
- [4] R.C. Daniels and R.W. Heath, "60 GHz Wireless Communications: Emerging Requirements and Design Recommendations," IEEE Vehicular Technology Magazine, vol. 2, no. 3, pp. 41-50, Sept. 2007.
- [5] C. Cao and K.K. O, "Millimeter-wave voltage-controlled oscillators in 0.13-microm CMOS technology," IEEE Journal of Solid-State Circuits, vol. 41, no. 6, pp. 1297-1304, June 2006.
- [6] T. Miyazaki and F. Kubota, "PSK self-homodyne detection using a pilot carrier for multibit/symbol transmission with inverse-RZ signal," IEEE Photonics Technology Letters, June 2005, vol. 17, no. 6, pp. 1334-1336.
- [7] R.A. Pacheco and D. Hatzinakos, "BER analysis of self-heterodyne OFDM transmission scheme." IEEE Canadian Conference on Electrical and Computer Engineering, vol. 4, pp. 1953-1956, May 2004
- [8] Y. Shoji, M. Nagatsuka, K. Hamaguchi, and H. Ogawa, "60 GHz band 64 QAM/OFDM terrestrial digital broadcasting signal transmission by using millimeter wave self-heterodyne system," IEEE Transactions on Broadcasting, vol. 47, no. 3, pp. 218-227, Sept. 2001
- [9] A.G. Armada and M. Calvo, "Phase noise and sub-carrier spacing effects on the performance of an OFDM communication system," IEEE Communications Letter, vol. 2, no. 1, Jan. 1998, pp.