

# Innovative Design Principles of Old Stone Bridges as Part of the Road Network of Greece

Nikolaos Alamanis<sup>1</sup>, Grigorios Papageorgiou<sup>2</sup>, Nikolaos Barelie<sup>3</sup>

Applications Professor, Department of Civil Engineering, Technological Educational Institute of Thessaly,  
Larissa, Greece<sup>1</sup>

Adjunct Lecturer, Department of Civil Engineering, Technological Educational Institute of Thessaly, Larissa, Greece<sup>2</sup>

P.G. Student, Department of Civil Engineering, Technological Educational Institute of Thessaly, Larissa, Greece<sup>3</sup>

**ABSTRACT:** In the Greek geographical area, there are many hundreds of arched bridges, which have been constructed with traditional methods and materials, from antiquity to the period of the interwar, when the generalized use of reinforced concrete began in the technical works. Most of the stone bridges are no longer used; some are located in remote and inaccessible mountainous locations, while few are still offering their services for the passage of people, animals and vehicles over rivers and streams.

The technique of bridges has been developed in Greece since ancient times, with a different but every-time style of construction. In Crete and the Peloponnese (mainly in Argolida), stone bridges are preserved from the Minoan and Mycenaean periods, respectively, which are structured with the freestanding system, ie with stone walls, leaving a triangular shaped hole with the top upwards. The passage of water. The construction of the circular arc to bridging the gap between two vertical structural elements is not an unknown technique in ancient Greece. However, few stone arched bridges from the Classical and Hellenistic periods are preserved in the Greek space.

**KEYWORDS:** Road network, Stone bridges, Building techniques.

## I. INTRODUCTION

The Romans, wicked builders of technical works, were particularly distinguished for their performance in bridge construction. They improved the building art by introducing the cast stones and established the bridges to use the full semicircular arc, that is, the arch that forms a perfect semicircle. The Roman bridges were distinguished for their solidity and were part of the famous Roman road network, which was built for military purposes. However, even from the Roman period, few examples of such bridges are preserved in the Greek space.

Some typical cases of bridges from ancient and Roman times in Greece are the Mavrouzouna bridge in MeligalaMessinia, the bridge of Aggitis, also known as Kantim of Kipro, near the village of ContlioSerres, a saved arch from a large bridge in Pinios between Omolio and In Pyrgetos of Larissa, whose first construction dates back to antiquity, the bridge in Xirokambi of Lakonia and others.

It seems that the remarkable Roman know-how in bridges did not improve during the Byzantine period. In Greece, only a few samples of Byzantine road construction survive to this day. A representative type of post-Byzantine bridge is the five (first) bridge of Karytaina Arcadia in the Alfios River.

Most of the bridges that were preserved today were built during the Ottoman domination. Some bridges of this period bear not a semicircular, but pointed arch. The style of the arctic arch features mainly Islamic eastern art, although it was known to the Byzantines and Western Europeans from much earlier. Indicative examples of such bridges are the bridge of Kokkoris in the river of Lousios in Gortynia, the bridge of Tsipianis in eastern Zagori, the bridge between Zerma and

# International Journal of Innovative Research in Science, Engineering and Technology

(An ISO 3297: 2007 Certified Organization)

Website: [www.ijirset.com](http://www.ijirset.com)

Vol. 6, Issue 6, June 2017

Drosopigi of Konitsa, the bridge of Kiupri of Edessa, the bridge of Agistas in the river Aggitis of Serres and others. At the end of the 19th century, and especially in the first half of the 20th century, many stone bridges with the most advanced technology of the arched arc, namely the arc that is smaller than a semicircle, were built in the Greek area and give the arch of the bridge a face that resembles an elliptical part Arc. Since the Ottoman domination, most of the long arc lengths and heights, the bridges or monotocks, are the stone bridges of the Greek area.

The construction of the bridges is connected with many legends that the verbal tradition has saved. Others refer to the drowning of people in the raging waters of the rivers, which became the cause or the reason for the construction of a bridge, and others, the most well-known, refer to the stakes, that is, to the embankment of humans or animals, in order to secure the bridge. The legends of the element are linked to the collapse of the bridges during their construction or completion, and are part of a wider cycle of beliefs for human sacrifices, with the aim of defeating evil spirits in the construction of a technical work that have a pan-European or worldwide spread from The ancient years until recently. It is characteristic that the legend of the mantship on the bridge of Arta can be found in Greece in 333 different variants. The tradition for the sacrifice of his wife, the mastermaster, refers to other large and well-known bridges of Greek space, such as the bridge of Kyra in the Peloponnese and the bridge of Pasha in Western Macedonia.

Regarding the geographical distribution of the surviving stone bridges in Greece, their density is higher in Western Greece than in the East. The most intense terrain and most of the rainfall observed in Epirus and West Central Greece are the reasons that in these areas there are, in proportion to their extent, more bridges than in Macedonia, Thessaly, EasternSterea in Thrace and in Peloponnese. It is indicative that the student of the Epirus stone bridges Spyros Mantas identified 367 bridges in the area of Epirus, of which 140 in the region of Zagori. The most representative examples of the species are the legendary bridge of Arta and the monotonous bridges of Konitsa in Aaos and Plaka in Arachthos, with an arc of about 36m and 39m, respectively. However, the largest bridge opening in the whole Greek area and probably in the Balkan area had the Korakosbridge in Acheloos with an arc opening of 45 meters, which was exploded in 1949. A multitude of small usually bridges exist in eastern Macedonia, while small stone arched bridges exist even on islands such as Lesbos, Lemnos and Crete.

Most of the stone bridges in Greece today have significant wear and tear over time. These are mainly due to weather conditions (frosts, rains) and are presented either as a subsoil of foundations and as the erosion of foundation soil due to water action, or as debris of stones and mortars, but also in other forms.

## II. RELATED WORK

Several researchers have studied old stone bridges in Greece. NitsaSiniki-Papakosta[1] presented the old stone bridges of the prefecture of Ioannina, Spyros Mantas [2], EviBeligianni[7] and ArgyrisDimitrakis[3] dealt with bridges of the whole Greek territory, Spyros Mantas [8, 5, 4] presented the Epirus prefecture old bridges and Aristides Schichmen[6] wrote a book recording the Arachthosregion constructions.

## III. RETROSPECTION OF BRIDGE CONSTRUCTION

Sometimes an image may contain text embedded on to it. Detecting and recognizing these characters can be very important, and removing these is important in the context of removing indirect advertisements, and for aesthetic reasons.

The development of bridges followed the development of road construction and, by extension, transport. Although this evolution was continuous, three distinct phases can be distinguished by the introduction of the processed stone by the Romans around 200 AD as a dividing point. And cast iron in the late 18th century.

- Phase 1: 4000 BC - 200 BC

Use of raw or slightly processed materials such as large slabs, boulders, logs and large branches of trees etc.

- Phase 2: 200 BC - 1780 AD

Use of partially processed materials such as carved stones and wooden beams of various shapes and sizes.

- Phase 3: 1780 AD - today

# International Journal of Innovative Research in Science, Engineering and Technology

(An ISO 3297: 2007 Certified Organization)

Website: [www.ijirset.com](http://www.ijirset.com)

Vol. 6, Issue 6, June 2017

Use of fully processed materials such as iron, steel and reinforced concrete.

Analytically:

Phase 1: 4000 BC - 200 BC

The first bridges were made of materials provided by nature with minimal human processing. People used either tree trunks or large stone slabs to bridge streams and small rivers (Figs. 1, 2).

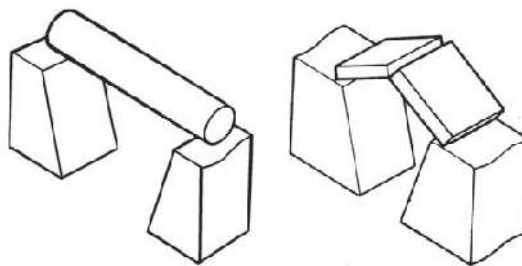

Fig. 1. Bridge with tree trunks      Fig. 2. Bridge with stone slabs

A remnant of these bridging bridges is the "lessia" or "liassa", which is still found today over small rivers of the Greek countryside. "Lessia" is the most typical case of crafted and exclusively wooden bridging, which is made with broken but deserted tree branches, is not supported by pediments rather than riparian healthy trees or massive rocks and is constructed quickly and easily and at a low cost (Figs. 3, 4).



Fig. 3. Lessia in Acheloos river



Fig. 4. Lessia in Kalamas river

In attempting to build a safer bridge, two or four parallel tree trunks were placed on stone plinths and above them fixed the wooden deck vertically, as shown in Figures 5 to 8.

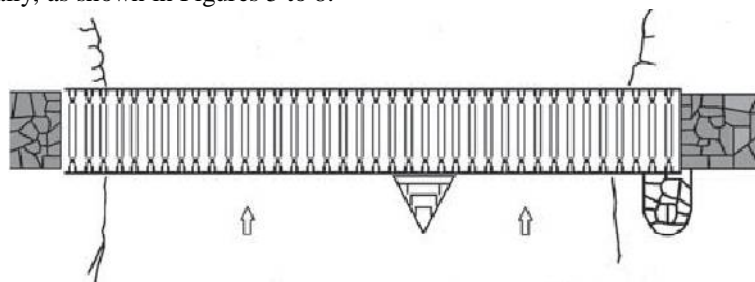

Fig.5. Bridge with stone pedestals and wooden deck

# International Journal of Innovative Research in Science, Engineering and Technology

(An ISO 3297: 2007 Certified Organization)

Website: [www.ijirset.com](http://www.ijirset.com)

Vol. 6, Issue 6, June 2017



Fig. 6. Sarantaporos river

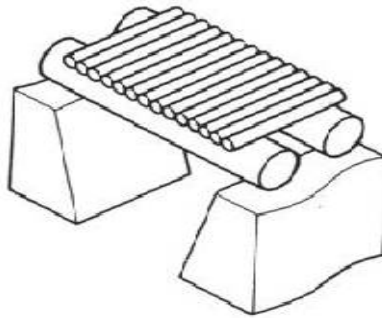

Fig.7. Wooden deck on tree trunks



Fig.8. Stone pedestals

Herodotus reports that for the Euphrates bridge in Babylon, they built every 9 m of 9 m thick stone gutters and supported wooden beams on them, some of which were removed at night for safety.

Wooden beams have been used not only in the bodies, but also several times in the gutters.

Such a bridge with three wooden galleries and a wooden carrier existed on the Aaos river between Vrysochori and Palioseleio - Paedons in the region of Konitsa, Ioannina, which was burned by the retreating Hellenic Army on 31/10/1940, as described in the written testimony of Mr. Giorgis Oikonomou, resident of Vrysochorion, who then served as a cavalier of the Independent Order of Konitsa of the legendary 8th Infantry Division (Petronotis, 2001).

Hundreds of years ago, the Chinese had built a special bridge (Fig. 9), which was based on wooden canopies, that is to say, a series of three successive wooden beams resting on one end only.

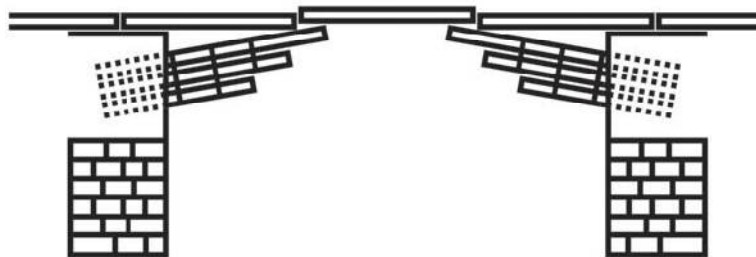

Fig. 9. Wooden bridge over wooden cantilevers

In 2000 BC, the Chinese built floating bridges (Figure 10). In 515 BC Samos Mandrocklis built a floating bridge in the Bosphorus for the Persian Darius. In the Second World War, the bridge was widely used.

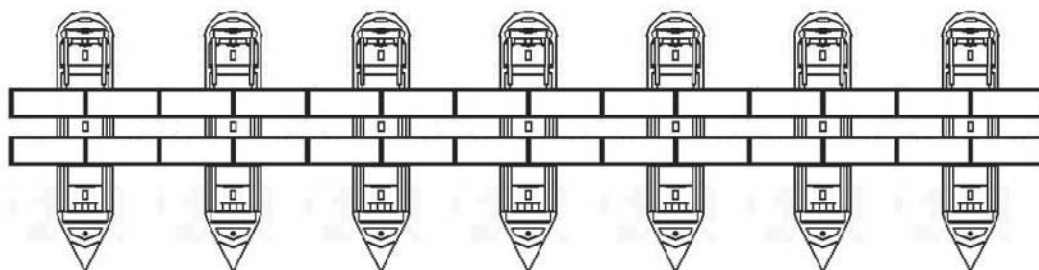

Fig.10. Bumblebee Bridge of World War II

## International Journal of Innovative Research in Science, Engineering and Technology

(An ISO 3297: 2007 Certified Organization)

Website: [www.ijirset.com](http://www.ijirset.com)

Vol. 6, Issue 6, June 2017

In 1500 BC, Mycenae built bridges with a large and horizontal stone beam (Figure 11) covering the gap between the opposite walls. Such is the bridge in Draconera in the northwest of the Acropolis of Mycenae. Gradually the Mycenae bridges were based on the freight construction system. The cover of the openings was made of masonry and each upper layer protruded from the lower one, creating stone headings (Figure 12). The Mycenaeans further developed the bridges bridge construction system by building converging arcs that meet in the acute peak with a vertical joint, thus creating pseudo-ends with triangular apertures (Figure 13).

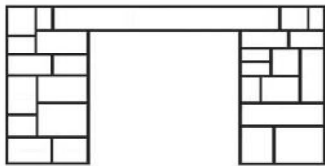

Fig. 11. Mycenae bridge type I

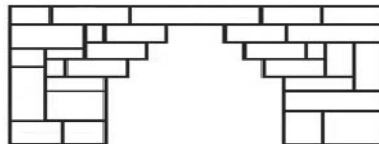

Fig. 12. Mycenae bridge type II

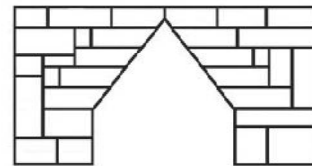

Fig. 13. Mycenae bridge type III

### Phase 2: 200 BC - 1780 AD

The Roman engineers are the first to understand and develop since the 2nd century BC, the potential of the genuine semicircular arc and the dome. The arches are thin and the pedestals are too thick (Fig. 14). In addition to the arched bridges the Romans and later the Byzantines built water bridges for water supplying cities. On Justinian, a water bridge (Fig. 15) was constructed for the water supply of Constantinople with a length of 240 meters and a height of 33 meters! In 14 AD, on Agrippa, the water bridge of Gard was built near Nim, France, and in 100 AD, on the Trajan, the bridge was built on the Alcantara River in Spain (Fig. 16).

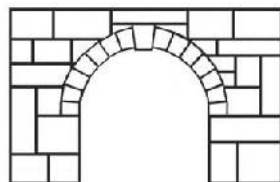

Fig. 14. Roman arch

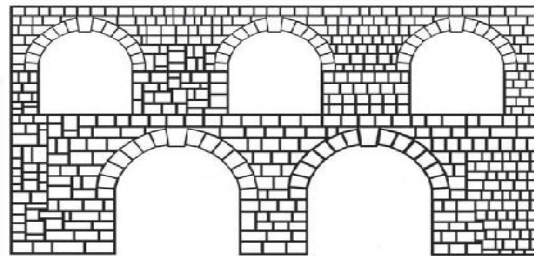

Fig. 15. Water bridge with two friezes

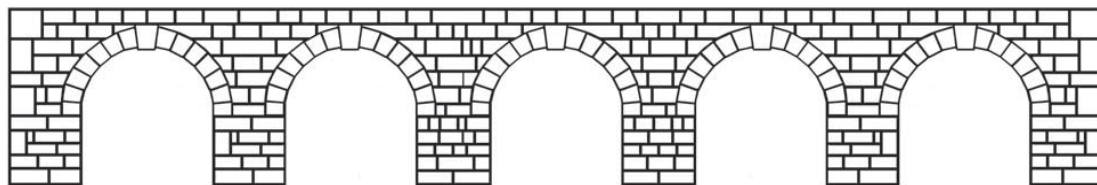

Fig. 16. Pentathodbridge from the Roman Empire

Until 1700 AD, the Roman tradition in the construction of bridges either continues with the semicircular arc (Fig. 17) or is influenced by the eastern rhythm with the oxygonal fracture of the arc. This second arc is called a scissor or a pinhole (Fig. 18).

# International Journal of Innovative Research in Science, Engineering and Technology

(An ISO 3297: 2007 Certified Organization)

Website: [www.ijirset.com](http://www.ijirset.com)

Vol. 6, Issue 6, June 2017

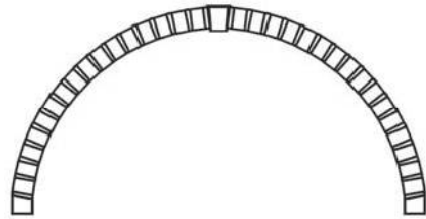

Fig. 17. Semi-circle arc

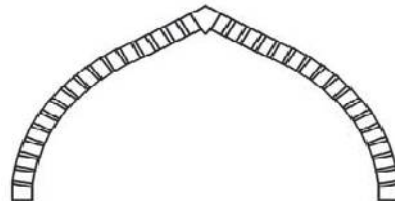

Fig. 18. Oval arc

Phase 3: 1780 AD until today

In the 18th and 19th centuries, folk art of the construction of stone arched bridges reaches its peak with fine arcs, durable pedestals, material economy, unsurpassed strength and high aesthetics.

## IV. MAIN TYPES OF STONE BRIDGES

The main types of stone bridges are:

- With horizontal beams
- With conveyor system
- With arched construction

### 1. With horizontal beams

Such constructions were used during prehistoric times, when they fell vertically into the streams, tree trunks facilitated their passage. This created the first "coupling" by placing a tabletop on two strong bases (pillars or pedestals). Such a kind of bridge we find in the western gate of Eretria in Evia (the second half of the 5th century BC).

### 2. With conveyor system

The freight system was used in prehistoric times. There are at least twenty relics of prehistoric bridges in the Mycenaean area, from which is drawing valuable information on the expertise that the Mycenaean technicians have developed over the kind of these bridges. Evidence for the use of this ecological system is the bridge located in Eleftherna, Crete (in the first half of the 4th century BC), in which the apertures have an opening of 3.83 m, covered with a dome vault of 1.85 m height.

### 3. With arched construction

The arched structure was known in the Classical and Hellenistic times and was used to cover mainly gates or vaulted tombs, but specialists of the time hesitated to use it for the construction of stone bridges. The arched bridges are semicircular to elliptical. There are the acute-pointed arcs, which are of the Eastern and Gothic type and are more easily constructed than the semi-circular ones. The engineer of the Roman years, in their effort to make shorter roads for the transport of troops and the movement of mail, goods and citizens, used the arched form for the construction of bridges.

There are the following forms of arched construction:

- In the heavy construction, dating from the ancient, classical to the early Roman era, the turquoise stones, the stones that make up the arch, are 40 cm long, 50 cm high and 15-25 cm wide and cone-shaped. Their facades are built with the isodomous system, ie with horizontal joints, with chiseled stones that are 70 cm long, 40 cm wide and 40 cm high. Another feature was the large stone slabs measuring approximately 90 cm long, 17 cm of thickness and 40 cm in width, placed on the deck of the stone bridge and protruding at least 10 cm from the rest of its body. A typical example of the heavy construction is the arches at the bridge of Syntolis.
- With light construction, dating back to the late Roman, Byzantine, Ottoman times until the modern Greek and early 20th century. All other bridges were built. Tholites have a length and a height of 30 cm and a width of 15 cm, while the remaining stones, which form the main body of the bridge, have a height and a width of 15 cm and a length of 35 cm. It is worth noting that a second arch embraces the first as a wreath from the top and protrudes at least 5 cm from the top

# International Journal of Innovative Research in Science, Engineering and Technology

(An ISO 3297: 2007 Certified Organization)

Website: [www.ijirset.com](http://www.ijirset.com)

Vol. 6, Issue 6, June 2017

of the first. This protrusion protects the bridge, because if the water passes through the joints, in the event of freezing, ice is created and a crack is created on the bridge.

## V. CONSTRUCTION METHODS OF STONE BRIDGES

- The location where the bridge will be built

The location and width of the river were the ones that would determine the shape of the bridge, ie whether it would be a single, two-or three-dimensional bridge, but also its dimensions, i.e. the length, width and opening of the arch. The most common preference for craftsmen was to lay the spikes on a rock to keep the foundations of the bridge stronger so that they are not in danger of being swept away by the rapids of the river during a downpour.

They also chose the narrowest rivers of the river to make small openings to be robust and safe and to withstand heavy loads passing over their deck. If there was rock in the bed of the river, they were rocking on the rock and making more arches that were smaller and safer. Otherwise, the position of the piers would be in shallow water.

- The construction of the arc

The most difficult and unpredictable task was the construction of the arch. The building of the arc started from the bottom upwards from the two edges, with two workshops working at the same time, and when they resumed at the top, they wedged the last stone (swollen) called the key. The name was symbolic because it locked the arch. The key to some bridges protruded above the deck of the bridge, giving the impression of a crown. Tholites were the stones with which they made the arc, and they were usually chiselled when they were made of porosity, natural, if they were granite. Their length and height were about 30 cm, reaching up to 45 cm, while the width from 15 to 20 cm. In some bridges, just above the arch, the craftsmen placed a second bow for more solid construction. The turrets of the second arc existed from those of the first; giving a different aesthetics to the whole image of the bridge, while protecting the joints of the first arc from the rain. At the Alistrati bridge there is a third arc just above the second arc.

- Choice of season

The best time to build bridges was in the summer and specifically from June to September. The biggest nightmare for the mastermind when building the vault was the flood of a sudden downpour, because during its construction, it was based on wooden columns that slid across the riverbed. As ArgyrisPetronotis characteristically states, the Omolios Petroleum Bridge was dulcimented by a downpour on AgiaSotira (August 6th) in 1811. In order to avoid the demonstrators of this type of destruction, they were trying to support the wooden columns on the rocks; otherwise they were setting anchorages directly on the stone pedestal of the bridge.

- The Foundation in the Plains

The foundations of the bridges in the rocky mountainous terrain were simple, while in the lowland and alluvial and sludgy soils it was very difficult because their stabilization was required, a technique known to our ancient ancestors, but was also used by the Romans in various foundations. For the stabilization of the soil they used wooden oak or chestnut piles, which were superficially slightly burned to avoid rotting. After the placement of the wooden piles, which was done by pumping water and sludge, the construction of a headband with a grid of cross beams, on which the foundations of the pedestal were built, was followed. Today, the same method is followed, but the wooden piles replaced concrete ones (shafts, injectors, mills).

- The material

The materials consisted of stones that were selected from the round area. Usually they were limestone, shale, and granites that are the hardest rock. The stones used to construct the arc were wedge-shaped; they were called turquoise and were usually made of carved limestone. The outer face of the bridge was made of carved stones, while the rest of the body was made of various untreated stones, carefully chosen by the craftsmen. Plasters and mortar commonly used for coatings consisted of tile trimmings, broken lime, pumice and water. As reinforcing materials straw, goat hair and egg whites were used in the mortar, which had the capacity to increase the binding capacity of the tire. In many bridges they used ironworks that were nailed to the body of the bridge, reinforcing its masonry.

# International Journal of Innovative Research in Science, Engineering and Technology

(An ISO 3297: 2007 Certified Organization)

Website: [www.ijirset.com](http://www.ijirset.com)

Vol. 6, Issue 6, June 2017

## VI. CHARACTERISTICS OF STONE BRIDGES

- The shape of the bridge

The shape of the bridge, depending on the number of arches it carries, is characterized as one-to-one, two-way, etc., i.e. consists of one, two or more arches respectively. When choosing the right location, it was in the judgment of the master and his crew to decide whether the bridge would be made with one or more arches so that the river link would be solid and safe while the good and comfortable flow of the river below. From the bridge set the opening and the height of each vault.

- The pedestals

The pedestals also played an important role in supporting the arch and generally across the static of the bridge. Thus, in a usually rushing river in which the height of the water surface was uncontrollable after some rainfall, the construction of the single-legged bridge with an arch opening was chosen such that the pedestals were as far away as possible from the rushing waters of the stream and, if was possible, standing on a rock. Also, if there was a rocky rock in the river bed, they were building a pedestal on it, so that the arches would become more and smaller in the open and of course safer. The pedestals had to be reinforced, because in addition to the pressure they received from the rushing water there were also the deposited materials, such as the mud, the branches and the trunks of the trees, which were drifting after intense rainfall and, in many cases, stamped the passage of water, so that the water overcame the bridge, exerting huge pressure on it, with the immediate danger of its collapse. A special way of enhancing the strength of the bridges was to construct protrusions or beams in front of the pedestals.

- The projections

When the construction of a bridge required many plinths built vertically in the river, to reduce the pressure exerted by the water on them, they constructed special protrusions that better accommodated the flow of water so that it passed under the arches. The protrusions, which were triangular and in several bridges in semicircular form, were usually made in the front of the pedestal but also in the back, in order to prevent the formation of a vortex in the water that would undermine the foundations of the pedestal. The pedestals that were one on the one side of the bed and the other on the other are called boulders.

- Pentecostals or windows

Just above the pedestals, the section between the two arches and up to the deck of the bridge was completed with masonry to make the deck more even. To avoid the risk of the bridge collapse and to reduce the pressure exerted by the masonry on the vaults of the arch, they created large or small openings (depending on the size of the bridge) that had a semi-circular or rectangular shape. Thus, large cargoes could pass through the deck of the bridge, while at the same time, when the torrent waters bubbled dangerously and feared to cover the entire bridge, these openings facilitated the passage of water, often preventing unpleasant consequences. These openings are called pseudo-frames or windows.

- Reinforcing or flushing

The entrance and the exit of each bridge were protected right and left by a retaining wall, which led the way to the deck of the bridge, used to strengthen the pedestals on which the arches were supported, facilitated the flow of water and at the same time reduced the pressure exerted. This in the pedestals. These walls are known as flank doors.

- The inscriptions

Upon the bridges of many bridges, they placed marble inscriptions (usually built-in), in which the sponsor and the date on which the bridge was built. Unfortunately, some (mainly goldsmiths), thinking that some treasure might have been hidden beneath these plates, degraded them, resulting in missing valuable information on the bridges along with them.

- The pavement and the ascending treadmill

The construction of the pavement on the pedestrian bridges varies according to their shape. Usually the ascent corridor was paved with stones, thus forming a cobbled path. In some bridges, the treadmill was tilted so that the passers-by did not slip, and the animals placed vertically on the carriageway and at regular distances a series of carved stones that protruded slightly. When the slope of the corridor was large and steep, they placed one or more rows of slightly staggered terraces.



## International Journal of Innovative Research in Science, Engineering and Technology

(An ISO 3297: 2007 Certified Organization)

Website: [www.ijirset.com](http://www.ijirset.com)

Vol. 6, Issue 6, June 2017

- Arcades

To protect the passers-by over a bridge, they placed on both sides of the pavement the arcades, which were upright stones and served as protective benches (parapets) that provided security to the passers-by. Such arcs are found on the bridge of the village of Lakkos outside Serres and at the bridge of Kalogeros in Epirus.

- The bell

In several stone bridges, under the arch and in the middle there was a bell hanging.

### VII. IDENTIFICATION OF STONE BRIDGES IN GREECE

One could wonder why it is difficult to record the stone arched bridges in Greece. The question is not rhetorical and the main answer is that it is not easy to identify. It is generally accepted by all scholars that the quads are easier to locate and record, since they are fewer than single-hills, are very large and are located in lowland areas that are easily accessible. Indeed, there are not many times when many of them have been converted to road bridges of the modern road network (Figs. 19 and 20).

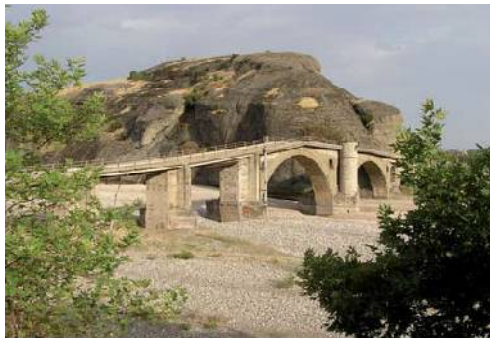

Fig. 19. Sarakina, Trikala



Fig. 20. River Aggitis, cave Maara

But the opposite is the case with the monotocks, which are medium or small in size and are located in the depths of inaccessible canyons, away from the roadways. In addition, the old paths that once led to them either are completely destroyed or closed or have been forgotten even by the locals. In addition, many have already been demolished or plunged into the artificial ponds of hydroelectric dams (Figs. 21 and 22).



Fig. 21,22. The Manolis bridge after a protracted drought 03/01/2007

# International Journal of Innovative Research in Science, Engineering and Technology

(An ISO 3297: 2007 Certified Organization)

Website: [www.ijirset.com](http://www.ijirset.com)

Vol. 6, Issue 6, June 2017

Therefore, the identification of monotonous stone bridges is a major problem that bridges researchers have to solve since it is possible to meet them literally anywhere. Of course, we can formulate some golden rules related to their search and say that stone arched bridges usually meet:

- in rivers that have a permanent and large flow of water such that their passage becomes impossible throughout the year.
- in mountainous areas and flats only if the bridge is near the final "exit" of the river from the narrow canyon to the open plain, as in the case of Konitsa, Ioannina, Trikala Gate, Portitses of the Grevena cave etc.
- in mountain settlements, through which a small or big river passes, such as Vovoussa Ioannina, DotsikosGrevena, Servia Kozani, EptahoriKastoria, MakrinitisaMagnisias, VourgareliArtas and elsewhere. In fact, in some cases there are more than one bridges in the same settlement, as in the case of Moustheni Kavala that there are four.
- on hiking routes that connect two nearby villages or on the old shopping streets to the major shopping centers of the area.
- at an altitude of less than 1,400 m, as higher sources and running waters are less and there are no rushing rivers, rather than small flowing streams.
- Just at the boundaries of mountainous settlements, when they are defined (usually on both sides) by the bed of a river, as in Syracuse, Ioannina, Makrinitisa and Tsagarada, Magnesia and many other cases.
- near some important buildings, such as a monastery (for example, Porta Panagia Bridge at Trikala Gate), a watermill (egChrysavgiKozani), a chapel, a fountain (a bridge at Syros, Ioannina), to which they must have Access to the inhabitants of all the neighboring villages
- the narrowest and rocky parts of the riverbed (egPaliokaryaTrikalon).
- near modern cement bridges, when the morphology of the river bed does not allow new bridging to a new location, as in the case of Politsa of Ioannina.

## VIII. CONSTRUCTION REPRESENTATION OF TRIPLE-ARC STONE BRIDGE IN TEN PHASES

Phase 1: Preliminary work

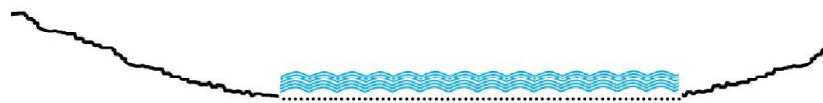

Fig. 1A. Selecting the bridging area

Prior to the construction work, what was at stake was the choice of the most appropriate point of the river bed offered for bridging. For this reason, the mistress along with the sponsor and prominent from the surrounding villages strolled up and down the riverbed. The most suitable point was a rocky slime.

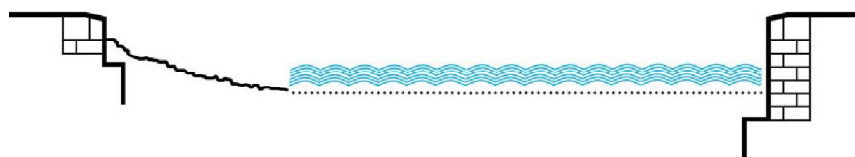

Fig. 1B. The formation of the bank and the construction of the thorns

# International Journal of Innovative Research in Science, Engineering and Technology

(An ISO 3297: 2007 Certified Organization)

Website: [www.ijirset.com](http://www.ijirset.com)

Vol. 6, Issue 6, June 2017

Then they set the brick, which had to have the right rock and it was close and higher than the bridging point to move the stones more easily. Then they formed the bank, removed the dirt until they found a solid rock. Still, they broke points of the rock and made "stairs" to push the acorns more firmly.

Phase 2: Construction of the two terraces

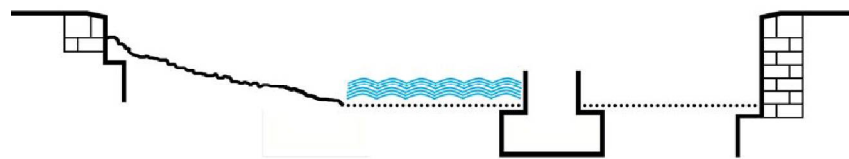

Fig. 2A. Diversion of the river flow, foundation and construction of the 1st terrace

It is well known that all construction or repair work was done only during the summer months, so as to have as little as possible and speed in the river waters. But many rivers, such as Aooos, are fed by many and rich springs and that's why they have enough water even in the summer. So, in order to be able to establish the rocks, they first had to make a small diversion-drainage of the river waters and then start digging into the bed.

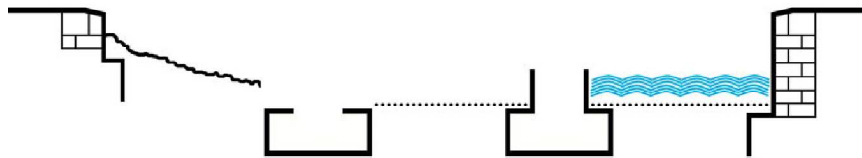

Fig. 2B. New diversion of the river flow, foundation and construction of 2nd basin

After turning the waters on one side, they dug deep into the bed, up to 5 meters, and "nailed" thick wooden poles. Then they began to build the foundations of the middle ground with large stones on the piles. Thus, they made paved foundations on all the birch bridges that bordered wide rivers, like Arta in Arachthos. After the construction of the 1st Gorge, the craftsmen made a new deflection of the river water to the opposite side of the bed and repeated the same process to construct the second middle ground.

Phase 3: Construction of canopies in the intersection

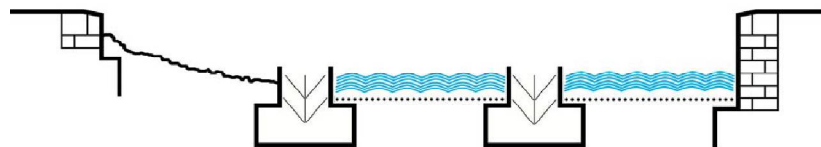

Fig. 3A: Construction of canopies at the terraces

Because the gorges are completely in or slightly above the deep river bed, they come in direct and constant contact with the degrading force of infinitely moving water. In addition, in cases of flooding, a strong hydrostatic pressure is exerted on the meadows. In order to protect the terraces, the craftsmen were projecting their front and back portions, e.g. in Arta.

# International Journal of Innovative Research in Science, Engineering and Technology

(An ISO 3297: 2007 Certified Organization)

Website: [www.ijirset.com](http://www.ijirset.com)

Vol. 6, Issue 6, June 2017

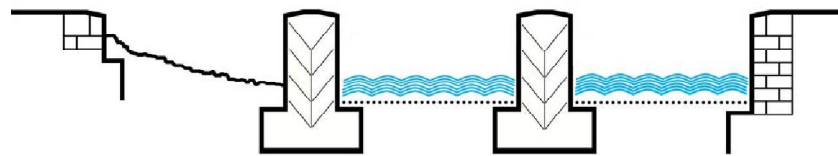

Fig. 3B. The canopies were built upstream and downstream

Depending on their shape, canvases are classified into 4 main categories. However, the most common and perhaps the most effective type of cantilever is the triangular cantilever such as those on the bridge of Arta.

Phase 4: Making a formwork

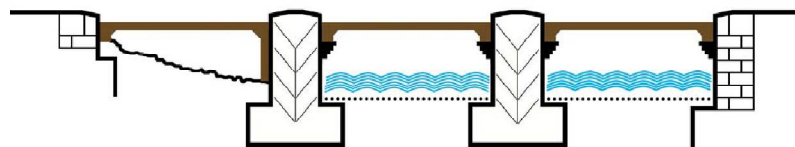

Fig. 4A. Construction of beams in the genesis of the stone arc

On the bases or arches of the arc, the formwork had to be laid. To do this, the craftsmen made recesses or protrusions in the pedestals, in or over which they would support the first horizontal beams of the formwork.

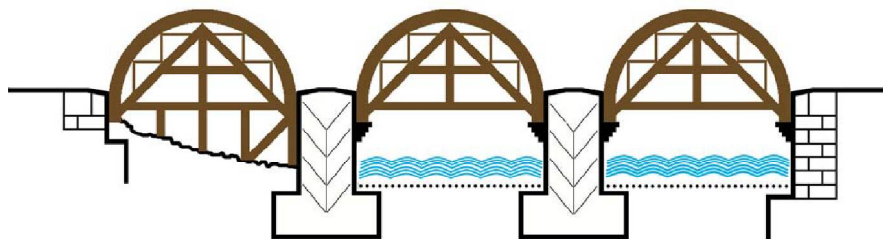

Fig. 4B. Supporting the "hanging" formwork in the beams

When the arc opened above a floodbed, they supported the woodcut on the bank. However, when the bow was opened above a deep bed, then the carpenters made a "pendant" woodcut that was based on the beams or scaffolds. Many times the craftsmen risked and put the woodcut in the deep bed, as in the repair of the Konitsabridge in 1913.

Phase 5: Construction of stone arches

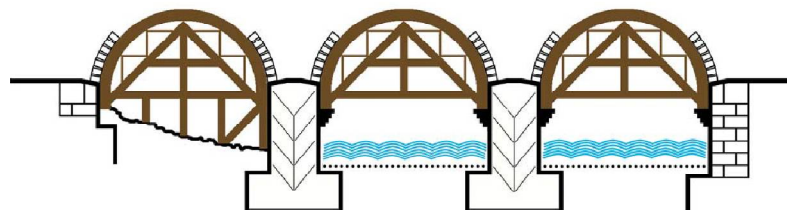

Fig. 5A. Placement of vault stones (tholites)

## International Journal of Innovative Research in Science, Engineering and Technology

(An ISO 3297: 2007 Certified Organization)

Website: [www.ijirset.com](http://www.ijirset.com)

Vol. 6, Issue 6, June 2017

Tholites were the finest stones that were equal in size and were built simultaneously on both sides of the arc. Tholites make up the first row of the arc, that is, the wreath or frieze.

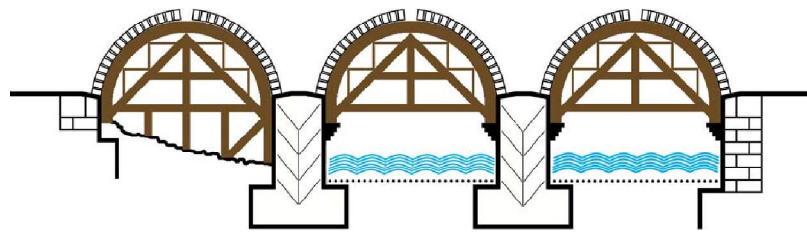

Fig. 5B. Place the "key"

At the highest point of the arc, where the arc "closed", the key, "the sacred stone" of the bridge, entered. It was the stone that hid all the secrets of the bridge, the one that gave all the others and kept them in their place. The forces began to move from the key, pushing them sideways, gradually moving to the bases. The carving of the key was done with great precision.

Phase 6: Construction of pseudo-carcasses and drums

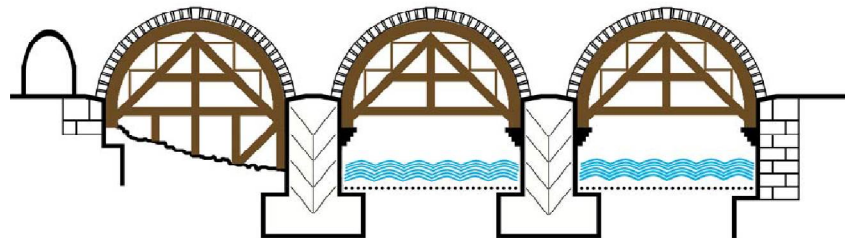

Fig. 6A. Construction of a pseudoemark in the floodplain bed

At the highest point of the arc, where the arc "closed", the key, "the sacred stone" of the bridge, entered. It was the stone that hid all the secrets of the bridge, the one that gave all the others and kept them in their place. The forces began to move from the key, pushing them sideways, gradually moving to the bases. The carving of the key was done with great precision.

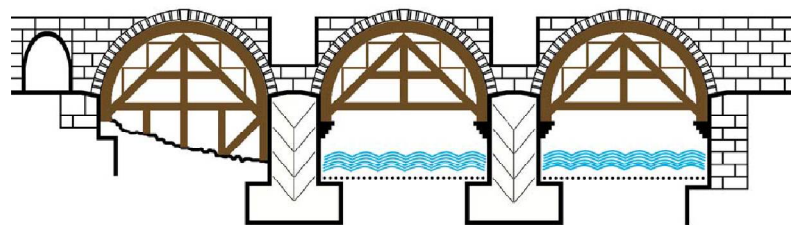

Fig. 6B. Manufacture of drums or flanges

After the completion of the central and other relieving arches, the craftsmen were filling the voids with stones that were irregular in shape and size and were chipped only on one side, the facade.

Phase 7: Construction of relieving arcs

Usually, on each of the slopes, the craftsmen built a relief arc for two reasons: firstly to make the masonry lighter and secondly to extinguish the hydrostatic pressure exerted on all the terraces in flood situations. The spectacle becomes more impressive in many bridges, such as Spanou in Grevena, as there are 5 main and 3 relievers.

# International Journal of Innovative Research in Science, Engineering and Technology

(An ISO 3297: 2007 Certified Organization)

Website: [www.ijirset.com](http://www.ijirset.com)

Vol. 6, Issue 6, June 2017

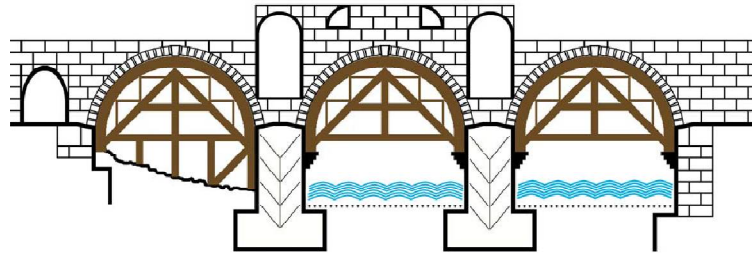

Fig. 7. Relieving arcs

Typically, the relief bows are semicircular but in a few cases the master's imagination has led to the construction of four-circle arcs (in Sarakina, Trikala) and double-arcs (in Giannouli, Evros).

Phase 8: Placing embossed or engraved plaques

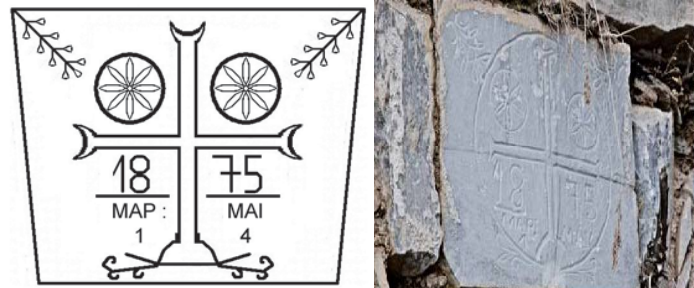

Fig. 8A. The inscribed plaque on the bridge of Patosia, in Makrinitza, Magnesia

Typically, these plates contained either decorative themes or valuable information about the bridge, e.g. date of construction (such as the bridge of Kato Kerasia in Pelion), name of sponsor or local lord and others. It is remarkable that they almost never contained information about the craftsmen who built it.

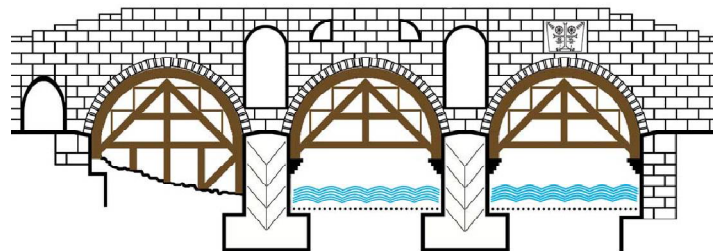

Fig. 8B: Placement of inscribed plaque with information

The most common place where the craftsmen placed these engraved plaques was just above the key to the highest arc of the bridge (like the Karyasbridge in Makrinitza, Pelion) or a drum.

## International Journal of Innovative Research in Science, Engineering and Technology

(An ISO 3297: 2007 Certified Organization)

Website: [www.ijirset.com](http://www.ijirset.com)

Vol. 6, Issue 6, June 2017

Phase 9th: Construction of deck and guardrail

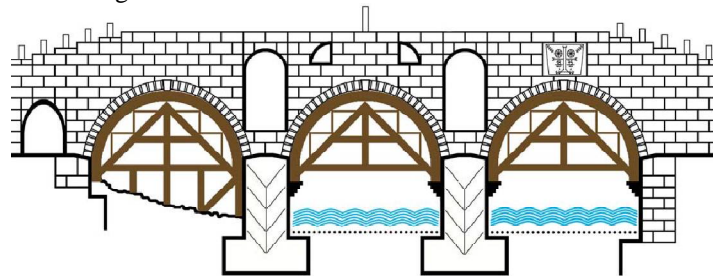

Fig. 9A. The construction of a paved deck (cobblestone)

The builders used slightly chopped stones to lay them on the deck of the bridge, just as they did with the cobbled streets (cobbled streets) that exist within and between many settlements. The way they are constructed and their purpose to serve safe and easy transit remains the same.

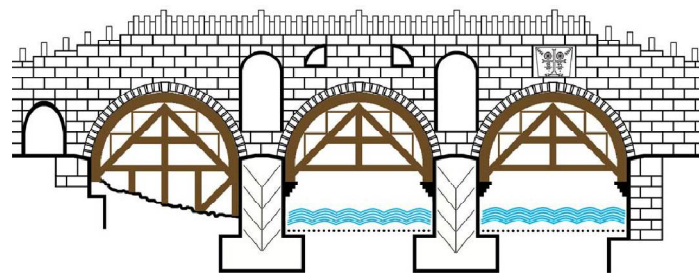

Fig. 9B. The installation of protective stone pillows

In Greece, the height of the arches usually ranges from 2 m up to 20 m. Therefore, the higher the arc, the more dangerous the passage is. For this reason, the craftsmen built the arcades at the deck's ends either individual (Syngounis bridge) or agglomerated on a parapet (Klidonia bridge).

Phase 10: Removal of formwork and delivery of the bridge

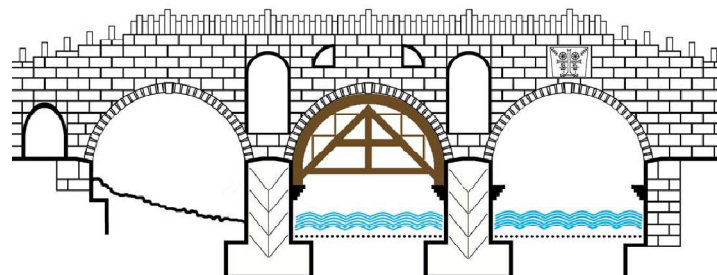

Fig. 10A. Gradual removal of molds

The caravans with great care and calm use the shutters and the special detonators to remove the formwork. The restoration started from the top and ended at the bottom of the formwork. First they removed the woodcut that was in the floodbed, then the one who supported the smallest bow and in the end removed the one that was above the deep bed. The risk to the craftsmen was great, because many bridges had collapsed when the form was removed.

## International Journal of Innovative Research in Science, Engineering and Technology

(An ISO 3297: 2007 Certified Organization)

Website: [www.ijirset.com](http://www.ijirset.com)

Vol. 6, Issue 6, June 2017

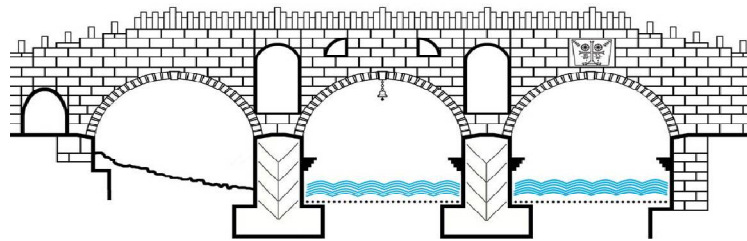

Fig. 10B. Placement of the small bell and delivery of the bridge

When the craftsmen had finished all the necessary construction work and before removing the middle arc of the middle arc, the foreman stood on the scaffold and hung the iron bell with the wide tongue in the middle of the arc. Several bridges with a high arc, such as Konitsa Ioannina and Aziz Aga in Trikamogrevena, had such a bell that banged loudly whenever a strong wind and a crossing of the bridge became extremely dangerous.

### IX. THE UTILITY OF THE STUDY OF OLD STONE BRIDGES FOR MODERN BRIDGE CONSTRUCTION

- The Ironbridge Bridge (Iron Bridge) near Coalbrookdale

It is the first leg of cast iron, a symbol of the Industrial Revolution. For the connection of the cast elements, logs, holes and slats were applied, according to the model of the wooden structures, while the members of the arcs were attached to the top with bolts.

- The hanging bridge in the narrow Menai (Welsh: Pont Grogysarth)

Linking the Anglesey Island to the Mainland of Wales is one of the first hanging bridges in the world. Classical stone-made semicircular arches lead to a central opening of 176m long, suspended from chain wires.

- Eads Bridge, St. Petersburg Louis, USA

When it was completed in 1874, it was the largest arched bridge in the world, with a total length of 1,964 m. The steel ribbon arches and the use of steel as a base material were considered bold for the time: it was the first time steel was used in a major bridging project. For the foundation of the mediterraneans and the docks it was necessary to use closed submersible boxes with external air supply, which had already been used in France. The construction of foundations began in 1867. Large submerged crates, made of steel sheets, were towed and pushed to the posts of the pedestals. The work chamber was compressed and the access was through airlocks. To remove the soft ground material of the bottom was used recently developed sand pumps. At the same time, in the cornice of the box, a masonry was constructed, which caused the box to be submerged further. Many of the workers suffered from the "disease of the divers" and there were several losses. The problem has been addressed by the application of slow decompression techniques and the improvement of working conditions

- The Forth Railway Bridge in Scotland (1890)

From the towers, rectangular cantilevers of 207 m length were built, constructed symmetrically to ensure stability during erection. The vectors of the bridge are isostatic, which greatly facilitated calculations. Notable is the number of accidents that occurred during its construction (98 deadly, 270 injuries).

- The Plougastel Bridge, or Alber t-Loupe Bridge

It runs through the river Elorn near Brittany Brest in France. Its construction began in 1926 and was completed on 9 October 1930. Its total length is 888 m. The deck is mounted on arched bodies. The three central arches are 188m wide. The bridge was studied by Eugene Freyssinet, the pioneer of prestressed concrete, and was the first time that this technique was applied to bridges.



# International Journal of Innovative Research in Science, Engineering and Technology

(An ISO 3297: 2007 Certified Organization)

Website: [www.ijirset.com](http://www.ijirset.com)

Vol. 6, Issue 6, June 2017

## X. BENEFITS FOR CONSTRUCTORS – CONCLUSIONS

The study of the rock bridges contributes to modern bridges because it teaches us:

- Static

Static analysis of structures and in particular arctic bridges of one or more openings as well as triangular arches. The most important feature of the whole-body trimmers is that the bending moments that develop in their cross-sections are much smaller than those shown in the single-beam beams used to cover the same opening. It should be noted that the triangular arcs resist high stresses since (in many cases) the parabolic form of their carrier contributes to the zeroing of the bending moments solo the length of the carrier.

- Material boundaries

The knowledge of the marginal stresses of the construction materials in the strains of tension, compression and bending resulting from the combination of perfect technique with the construction of stone bridges contributes to the design of their reconstruction or to their reinforcement with modern materials harmonized with the environment.

- The limits of design solutions

The marvelous way of their construction, dating back to ancient times, demonstrates the exceptional construction details with which the stone bridges are built in their environment. It also demonstrates an important element of high cultural heritage that is probably the crown of the history of Greek road construction.

- The structural details that were selected to fit each bridge into its environment

The old stone bridges, scattered around every corner of Greece, are convincing signs of reference in the past. Then the lack of media was replenished by experience and enthusiasm. Perhaps because in the Greek countryside there were no foreign standards or even technical means to impose any inspiration. That it was created was the result of a dialogue and a decent compromise with the environment.

- The relationship between a work and the historical context that gave birth to it – Aesthetics

The knowledge and experience of folk craftsmen as well as intelligent designs, combinations, maneuvers have been transmitted from generation to generation, thus contributing to the high technical training and know-how of modern craftsmen and engineers as well as the professional world in general.

## REFERENCES

- [1] NitsaSiniki-Papakosta - Stone Bridges, Prefecture of Ioannina, 2002.
- [2] Spyros Mantas - Stone Bridges, Series The Treasures of Greece, Lambrakis Press, 2007.
- [3] ArgyrisDimitrakis- The Stone Bridges of Greece, Adam - Pergamos, 1999.
- [4] Spyros Mantas - Stone Bridges in Northern Epirus, Epirotes Bridges Archive -2008.
- [5] Spyros Mantas - The Bridge And Epirus, Technical Publishing, 1990.
- [6] Aristides Schichmen - The 55 Stone Bridges of Arachthos, Apiros Hora, 2001.
- [7] EviBeligianni - Seeking the Stone Bridges of Greece, Lebanon - New Borders, 2007.
- [8] Spyros Mantas - The Epirus Bridges, Technical Publishing, 1984.
- [9] Barelle Nikolaos, 2014. BSc Thesis "Stone-made bridges in the Greek territory". Department of Civil Engineering, Technological Educational Institute of Thessaly. Larissa, Greece.
- [10] Center of Environmental Education of Makrinitza, 2007. The stone arched bridges of Greece. ISBN 9789609804394. Volos, Greece.
- [11] Haratsis Nikos, 1999. Stone arched bridges in Pelion. ISBN 9608446007. Volos, Greece.
- [12] KouvatasStergios, 2012. Historical and urban development of Pelion. Volos, Greece.
- [13] Mytilene Experimental Lyceum, 2011. Characteristic examples of traditional bridges in the Greater Greece. Mytilene, Greece.
- [14] Tilkidis Athanasios F., 2006 - The stone bridges of Serres. ISBN 9608564832. Serres, Greece.
- [15] Zagorohoria - Traditional bridges – [http://www.about-ioannina.gr/Ioannina\\_gr/Ioannina.htm](http://www.about-ioannina.gr/Ioannina_gr/Ioannina.htm)
- [16] Bridges - Municipality of Konitsa –<http://www.konitsa.gr/>
- [17] The stone arched bridges of Pelion –[http://www.endiaferomai.gr/index.php?option=com\\_content&view=article&id=317:2013-05-04-09-12-14&catid=51:articles-e&Itemid=105](http://www.endiaferomai.gr/index.php?option=com_content&view=article&id=317:2013-05-04-09-12-14&catid=51:articles-e&Itemid=105)
- [18] Regional unit of Grevena –[http://www.grevena.gr/perivallon/index.php?option=com\\_content&task=blogcategory&id=54&Itemid=175](http://www.grevena.gr/perivallon/index.php?option=com_content&task=blogcategory&id=54&Itemid=175)
- [19] The stone bridges of Greece –  
<http://petrinagefira.com/content/%CF%87%CF%81%CE%AE%CF%83%CE%B9%CE%BC%CE%BF%CE%B9-%CF%83%CF%8D%CE%BD%CE%B4%CE%B5%CF%83%CE%BC%CE%BF%CE%B9>