

# International Journal of Innovative Research in Science, Engineering and Technology

(An ISO 3297: 2007 Certified Organization)

Website: [www.ijirset.com](http://www.ijirset.com)

Vol. 6, Issue 3, March 2017

## Load Compensation by Using STATCOM

Parkhe Akshay<sup>1</sup>, Bendre Abhijeet<sup>1</sup>, Devkar Rohan<sup>1</sup>, Bhong Vishal<sup>1</sup>, Prof. S.D. Mangate<sup>2</sup>

Student, Department of Electrical Engineering, College of Engineering, Malegaon (Bk), Savitribai Phule Pune University, Pune, India<sup>1</sup>

Professor, Department of Electrical Engineering, College of Engineering, Malegaon (Bk), Savitribai Phule Pune University, Pune, India<sup>2</sup>

**ABSTRACT:** This project presents a technique to enhance the stability of a grid-connected wind farm composed of a fixed-speed wind turbine generator system (WTGS) utilizing a combination of a small series dynamic braking resistor (SDBR) and static synchronous compensator (STATCOM). The SDBR and STATCOM have active and reactive power control capacities, respectively, and a combination of these units paves the way to stabilize well the fixed-speed wind farm. A Static Synchronous Compensator (STATCOM) is applied to a power network which includes a SCIG driven by a wind turbine, for steady state voltage regulation and transient voltage stability support. The STATCOM is controlled by using PQ controller technique with voltage regulation as basic scenario. Results illustrate that the STATCOM improves the transient voltage stability and therefore helps the wind turbine generator system to remain in service during grid faults. The time to reach steady state torque and speed without using vector control or direct torque control can also be achieved by using this STATCOM control technique. In this paper, a centralized control scheme of using an SDBR and a STATCOM together is focused, which can be easily integrated with a wind farm.

**KEYWORDS:** SDBR, stability, STATCOM, torsional oscillation, wind farm.

### I. INTRODUCTION

The industry worldwide is turning progressively to renewable sources of energy to generate electricity. Wind is the fastest developing and most broadly used of the rising renewable energy technologies in electricity systems at present, with a total of 194.4 GW installed worldwide at the end of 2010. Variable-speed wind turbine generator systems (WTGS) are getting more attraction than the fixed speed nowadays. In any case, fixed-speed WTGS technologies still retain a sizeable share on the wind power market because of their superior characteristics for example, brushless and rugged construction, low cost, maintenance free, and operational simplicity. The fixed-speed WTGS that uses an induction machine as a wind generator has the stability problem similar to a synchronous generator (SG). This study focuses on both transient and dynamic stability improvement issues of the fixed speed WTGS. The fixed-speed WTGS that uses an induction machine as a wind generator has the stability issue like to a synchronous generator (SG). This study focuses on both transient and dynamic stability improvement issues of the fixed-speed WTGS. Subsequently, centralized SDBR and STATCOM are considered to be connected at the terminal of a wind farm that connects the power system to observe the effectiveness of the proposed system during normal and grid fault conditions, in this review. Where the components are expressed utilizing a simple transfer function, realistic component modelling is considered in this study using the laboratory standard power system software package PSCAD/EMTDC. Power generation using wind energy deals with systems from engineering and science disciplines, e.g., mechanical, electrical, electronics, computer, and aerospace engineering. This study specially focuses on two electrical systems, i.e., SDBR and STATCOM, including their control aspects to improve the stability of a wind energy conversion system along with the improvement of turbine blade-shaft torsional damping. To determine the minimum size required for both SDBR and STATCOM units to withstand against grid fault and to maintain constant terminal voltage during randomly varying

# International Journal of Innovative Research in Science, Engineering and Technology

(An ISO 3297: 2007 Certified Organization)

Website: [www.ijirset.com](http://www.ijirset.com)

Vol. 6, Issue 3, March 2017

wind speed condition, extensive simulation studies are performed. Power Generation and Transmission is a complex process, requiring the working of many components of the power system in tandem to maximize the output. One of the main components to form a major part is the reactive power in the system. It is required to maintain the voltage to deliver the active power through the lines. Loads like motor loads and other loads require reactive power for their operation. To enhance the performance of ac power systems, we need to manage this reactive power in an efficient way and this is known as reactive power compensation. There are two perspectives to the problem of reactive power compensation: load compensation and voltage support. Load compensation consists of improvement in power factor, balancing of real power drawn from the supply, better voltage regulation, etc. of large fluctuating loads. Voltage support consists of diminishment of voltage fluctuation at a given terminal of the transmission line. Two types of compensation can be used: series and shunt compensation. These modify the parameters of the system to give enhanced VAR compensation. In recent years, static VAR compensators like the STATCOM have been produced.

## Static Synchronous Compensators (STATCOM)

One of the numerous devices under the FACTS family, a STATCOM is a regulating device which can be used to regulate the flow of reactive power in the system independent of other system parameters. STATCOM has no long term energy support on the dc side and it can't exchange real power with the ac system. In the transmission systems, STATCOMs primarily handle only fundamental reactive power exchange and give voltage support to buses by modulating bus voltages during dynamic disturbances in order to provide better transient characteristics, improve the transient stability margins and to damp out the system oscillations because of these unsettling influences. A STATCOM consists of a three phase inverter (generally a PWM inverter) using SCRs, MOSFETs or IGBTs, a D.C capacitor which provides the D.C voltage for the inverter, a link reactor which links the inverter output to the a.c supply side, filter components to filter out the high frequency components due to the PWM inverter. From the d.c. side capacitor, a three phase voltage is generated by the inverter. This is synchronized with the a.c supply. The link inductor links this voltage to the a.c supply side. This is the basic principle of operation of STATCOM. For two AC sources which have the same frequency and are connected through a series inductance, the active power flows from the leading source to the lagging source and the reactive power flows from the higher voltage magnitude source to the lower voltage magnitude source. The phase angle difference between the sources determines the active power flow and the voltage magnitude difference between the sources determines the reactive power flow. Along these lines, a STATCOM can be utilized to regulate the reactive power flow by changing the magnitude of the VSC voltage with respect to source bus voltage.

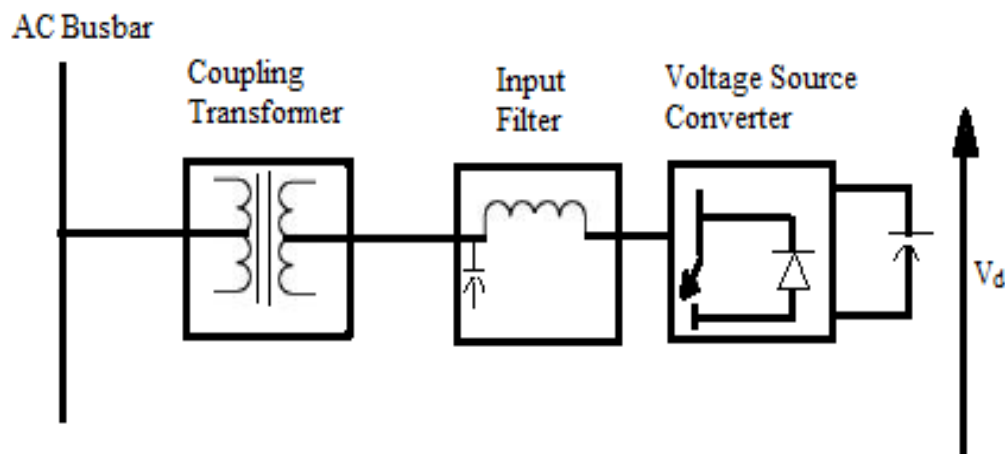

Fig.1 Static Synchronous Compensator

# International Journal of Innovative Research in Science, Engineering and Technology

(An ISO 3297: 2007 Certified Organization)

Website: [www.ijirset.com](http://www.ijirset.com)

Vol. 6, Issue 3, March 2017

## II. LITERATURE REVIEW

Gaurav Tembhurnikar, Ajit Chaudhari, Nilesh Wani, Atul Gajare, Pankaj Gajare [1], have presented various techniques of reactive power compensation needed by any power system network using FACTS device. It is better solution to any power transmission related problems in today's world to implement FACTS device for either lagging or leading behaviour of power system network. In this paper we study the shunt operation of FACTS controller, the STATCOM and how it helps in the better utilization of a network operating under normal conditions. Firstly, a literature review of many papers related to FACTS and STATCOM, along with reactive power control are to be considered and analysed.

Ahmed Abu Hussein and Mohd. Hasan Ali [2], have presented comparison among series connected auxiliary devices, such as Superconducting Fault Current Limiter (SFCL), Dynamic Voltage Restorer (DVR), Thyristor Switched Series Capacitor (TCSC), and Series Dynamic Braking Resistor (SDBR), is performed in terms of fault ride through capability improvement, harmonics suppression, controller complexity, and cost of a fixed speed wind generator system. The SFCL is the costliest among all devices, however, it is the most efficient in reducing the fluctuations of active power and stator current of the wind generators. The SDBR is the cheapest, and shows a better enhancement in damping active power and limiting fault current as compared to the DVR and TCSC.

Shervin Samimian Tehrani<sup>1</sup>, Peyman Salmanpour Bandaghirri [3], have presented the Simulation of a 14-bus system using STATCOM compensated by applying the error and see the impact of the voltage compensator buses. Voltage stability of a system is affected by reactive power limit of the system. FACTS devices improve the reactive power flow in system thereby improving voltage stability. This paper explores the effect of STATCOM on static voltage stability. IEEE 14 bus system has been used to demonstrate the ability of STATCOM in improving the voltage stability margin. These FACTS controllers help to increase the load ability margin of the power network.

P. Venkata Kishore, Prof. S. Rama Reddy [4], have presented D-STATCOM, a shunt connected FACTS device which supplies reactive power to the load to improve the voltage stability of the load busses. The D-STATCOM in multi bus system is capable of reducing the losses and improving the voltage regulation. This work deals with comparison of Push Pull and Voltage Inverter based D-STATCOM for multi bus system. Eight bus system is modeled using the elements of SIMULINK. The models are developed for eight bus system with and without D-STATCOM. The two D-STATCOM systems are compared with respect to total harmonic distortion and reactive power comparison. The D-STATCOM is studied with respect to the voltage stability improvement at the load busses.

Parimal Borse, Dr. A. G. Thosar, Samruddhi Shaha [5], have presented model and simulation of Flexible Alternating Current Transmission Systems (FACTS) device, namely, Static Synchronous Compensator (STATCOM). The STATCOM a solid-state voltage source inverter and DC side capacitor is tied to a transmission line. A STATCOM injects an almost sinusoidal current, of variable magnitude, at the point of connection. This injected current is almost in quadrature with the line voltage, thereby emulating an inductive or a capacitive reactance at the point of connection with the transmission line. The functionality of the STATCOM model is verified by regulating the reactive current flow through it. This is useful for regulating the line voltage. STATCOM model is verified by regulating reactive power flow and is determined by using 6 pulses (two levels) IGBT based inverter. The mathematical modelling of STATCOM is simulated in MATLAB software for 10kVA rating.

# International Journal of Innovative Research in Science, Engineering and Technology

(An ISO 3297: 2007 Certified Organization)

Website: [www.ijirset.com](http://www.ijirset.com)

Vol. 6, Issue 3, March 2017

## III. PROPOSED SYSTEM

### 1. Basic Working Principle:

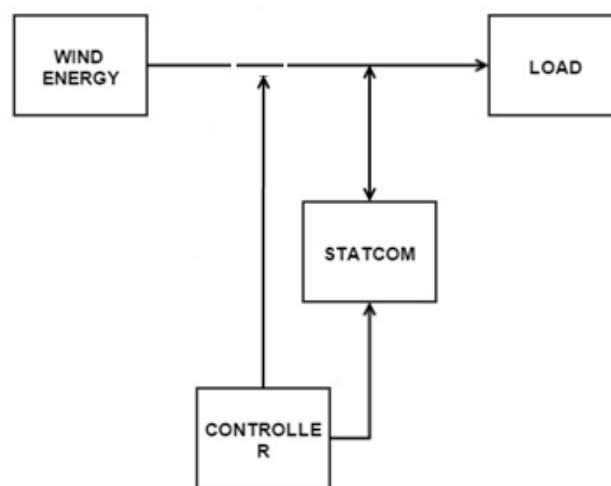

**Fig.2 Basic block diagram of proposed system**

Here, centralized SDBR and STATCOM are considered to be connected at the terminal of a wind farm that connects the power system to observe the effectiveness of the proposed system during normal and grid fault conditions. Figure 2 shows basic block diagram of proposed system. It consists of wind energy generation system, SDBR, STATCOM and controller to control STATCOM and SDBR action. A series dynamic braking resistor (SDBR) contributes directly to the balance of active power during faults and STATCOM contributes to regulate flow of reactive power. In normal operation, the wind farm terminal voltage deviates a lot due to the rapid wind speed fluctuations as the capacitor banks placed at the terminals of individual wind generators are designed to maintain a unity power factor under rated power conditions when the wind speeds are at rated values. The STATCOM will work during normal operation to maintain constant voltage at the wind farm terminal, and hence, the terminal voltage is set as the control input of the STATCOM in the coordinated control scheme. The STATCOM will also work during the grid fault condition when the terminal voltage falls below a threshold value. The SDBR works only during the grid fault condition along with the STATCOM to enhance the fault ride through capability of the wind farm when the terminal voltage falls below the threshold value.

# International Journal of Innovative Research in Science, Engineering and Technology

(An ISO 3297: 2007 Certified Organization)

Website: [www.ijirset.com](http://www.ijirset.com)

Vol. 6, Issue 3, March 2017

## 1.1 Basic working principle of STATCOM:

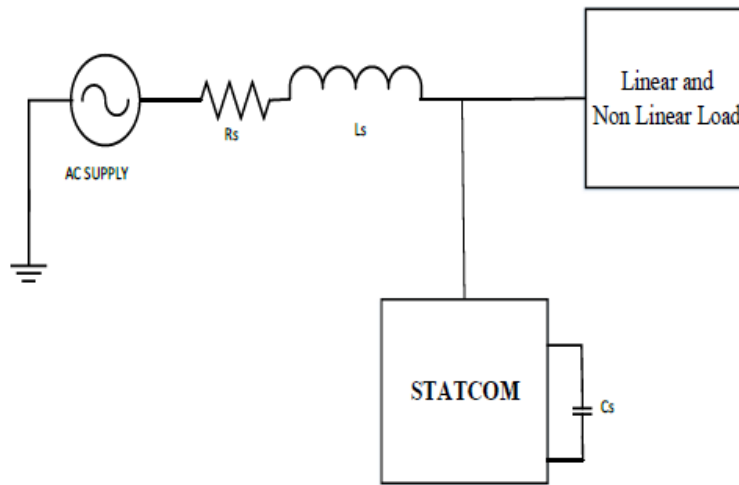

**Fig.3 Single line diagram of STATCOM in Distribution System**

As shown in figure 3, it consists of a dc capacitor, three-phase inverter (IGBT, thyristor) module, ac filter, coupling transformer. The basic single line diagram of the STATCOM in distribution system is the voltage sourced inverter that converts an input dc voltage into a three phase output voltage at fundamental frequency. According to Figure, the controller of the STATCOM is used to operate the inverter in such a way that the phase angle between the inverter voltage  $V_i$  and the system voltage  $V_s$  is dynamically adjusted so that the STATCOM generates or absorbs the desired VAR at the point of connection (PCC). The phase of the output voltage of the inverter  $V_i$ , is controlled in the same way as the distribution system voltage  $V_s$ .

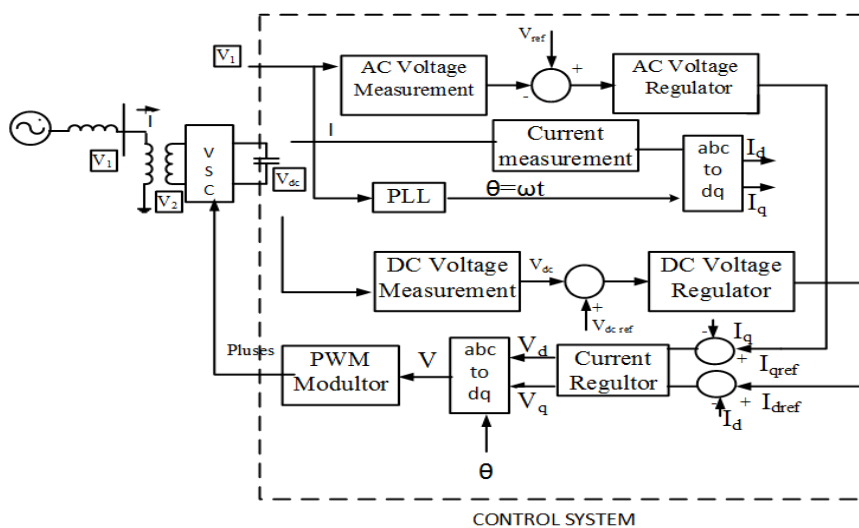

**Fig.4 Schematic diagram of STATCOM controller to reactive power compensation using SPWM technique**

## International Journal of Innovative Research in Science, Engineering and Technology

(An ISO 3297: 2007 Certified Organization)

Website: [www.ijirset.com](http://www.ijirset.com)

Vol. 6, Issue 3, March 2017

Fig.4 shows the control algorithm of STATCOM controller. For extracting gate pulses for VSC, first of all measure the PCC voltages ( $V_a$ ,  $V_b$ , and  $V_c$ ), PCC currents ( $I_{sa}$ ,  $I_{sb}$  and  $I_{sc}$ ) and DC bus voltage ( $V_{dc}$ ) of the STATCOM. PLL (phase locked loop) is use to continue track the fundamental frequency quantity in distorted condition and which can also extract the phase angle  $\theta$  of fundamental voltage, which is mainly use to synchronization of VSC to system. the control strategy applied for STATCOM consist of two control loops. An outer voltage regulation loop consist AC voltage measurement block which measure the system voltage  $V_{ac}$  and compare with one reference value  $V_{acref}$ , output of error single is applied to the AC voltage regulator(PI controller) which generate the reference current  $I_{qref}$  for inner current loop. Outer regulation loop also consist the DC voltage measurement block, which measure the DC input voltage of VSC.  $V_{dc}$  is compare with the some  $V_{dcref}$  value output of error signal is applied to the DC voltage regulator which generate the reference current  $I_{dref}$  for inner current loop. Where  $I_d$  = Direct axis current (current in phase with voltage which controls the active power flow),  $I_q$  = Quadrature axis current (current in quadrature with voltage which controls the reactive power flow).

An inner current regulation loop consisting AC current measurement block, which measure the system current using PLL block we extract  $\theta$ , by these  $\theta$  and  $I_a$ ,  $I_b$ ,  $I_c$  current, we can transformed  $I_a$ ,  $I_b$ ,  $I_c$  to  $I_d$ ,  $I_q$  using dq0 transformation (park transformation). These  $I_d$  and  $I_q$  compare with  $I_{dref}$  and  $I_{qref}$  respectively and output of these error signal is passing through the current regulators which consist the two separate PI controller which tuned to till the desired response is not get. PI controller is use due to it have low steady state error. Output of the PI controllers in current regulator is treated as  $V_d$  and  $V_q$ . then using the inverse dq0 transformation (inverse park transformation) we gate  $V_a$ ,  $V_b$ , and  $V_c$  applying to PWM modulator where comparing the these modulating signal  $V_a$ ,  $V_b$ , and  $V_c$  with any carrier frequency signal, we get gate pulse for VSC switches. The inner current loop is responsible for power quality issues like low THD and good power factor, whereas the outer voltage loop balance the power flow in the distribution system. Synchronous reference frame control is also called dq0 control which transforms the grid voltage and current into d-q frame. This transformed voltage detects the phase and frequency of grid whereas transformed current control the grid power. Thus the control variable becomes dc values hence filtering and controlling becomes easier.

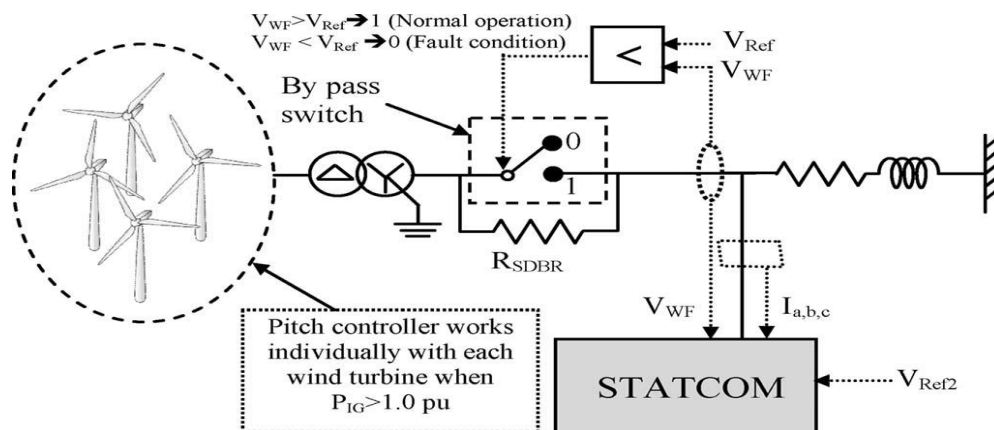

**Fig.5 Proposed coordinated control scheme for a wind farm.**

In this project, a coordinated control scheme is adopted among the SDBR, STATCOM, and pitch controller to stabilize the wind farm under dynamic and network fault conditions. The coordinated control scheme is schematically shown in Fig.5

# International Journal of Innovative Research in Science, Engineering and Technology

(An ISO 3297: 2007 Certified Organization)

Website: [www.ijirset.com](http://www.ijirset.com)

Vol. 6, Issue 3, March 2017

- 1) In normal operation, the wind farm terminal voltage deviates a lot due to the rapid wind speed fluctuations as the capacitor banks placed at the terminals of individual wind generators are designed to maintain a unity power factor under rated power conditions when the wind speeds are at rated values. The STATCOM will work during normal operation to maintain constant voltage at the wind farm terminal, and hence, the terminal voltage is set as the control input of the STATCOM in the coordinated control scheme. The STATCOM will also work during the grid fault condition when the terminal voltage falls below a threshold value.
- 2) The SDBR works only during the grid fault condition along with the STATCOM to enhance the FRT capability of the wind farm when the terminal voltage falls below the threshold value.
- 3) The pitch controllers are attached with individual wind generators and activate when the power exceeds the rated values of the generators. Therefore, wind generator output power is set as the input of the pitch controller. During the grid fault condition, the pitch controller will also activate when the wind generator power exceeds the rated values, particularly when the fault occurs at high wind conditions.

## IV. CONCLUSION

This paper has concentrated on the transient and dynamic stability augmentation of a grid-connected wind farm composed of fixed-speed WTGSs utilizing a combination of the SDBR and the STATCOM in a cost-effective proportion. From the extensive simulation analyses, it is found that a 0.3–0.35 p.u. SDBR (based on the system base) and a 20–25 MVA STATCOM (40%–50% of the wind farm capacity) is a good proportion to stabilize the transient and dynamic stabilities of the wind farm. This proportion is considered for analyzing all types of symmetrical and unsymmetrical fault conditions, and it is found that the wind farm FRT requirement is fulfilled as per recent grid code. It is also investigated that this proportion can essentially limit the blade–shaft oscillation of the fixed-speed WTGS, which is one of the important observations from this study. Finally, it is concluded that if the capacity of the SDBR and the STATCOM can be chosen properly, the combination will be a cost-effective means to augment the dynamic and transient stability of a grid-connected wind farm composed of fixed-speed WTGSs.

## REFERENCES

- [1] Gaurav Tembhurnikar, Ajit Chaudhari, Nilesh Wani, Atul Gajare, Pankaj Gajare, “A Review on Reactive Power Compensation Techniques using FACTS Devices”, International Journal of Engineering and Management Research Vol.4, Issue-1, February-2014.
- [2] Ahmed Abu Hussein and Mohd. Hasan Ali, “Comparison among Series Compensators for Fault Ride through Capability Enhancement of Wind Generator Systems”, International Journal Of Renewable Energy Research, Vol.4, No.3, 2014.
- [3] Shervin Samimian Tehrani, Peyman Salmanpour Bandaghi, “Shunt Compensation for Improvement of Voltage Stability Using Static Synchronous Compensator (STATCOM) for Various Faults in Power System”, International Journal Of Advanced Research In Electrical, Electronics And Instrumentation Engineering, Vol. 3, Issue 6, June 2014.
- [4] P. Venkata Kishore, Prof. S. Rama Reddy, “Compensation of Reactive Power Using D-STATCOM”, IOSR Journal of Electrical and Electronics Engineering (IOSR-JEEE), Vol. 9, Issue 1, PP 17-27, Jan. 2014.
- [5] Parimal Borse, Dr. A. G. Thosar, Samruddhi Shaha, “Modeling and Simulation of STATCOM”, International Journal of Engineering Research & Technology (IJERT), Vol. 3 Issue 12, December-2014.