

Experimental and Theoretical Investigation of Evacuated Tube Solar Collector with Heat Pipe

Siva Kumar S¹, Mohan Kumar K², Sanjeev Kumar S R³, Charles G⁴Assistant Professor, Department of Mechanical Engineering, Kumaraguru College of Technology, Coimbatore, India¹P.G. Student, Department of Energy Engineering, Kumaraguru College of Technology, Coimbatore, India^{2,3,4}

ABSTRACT: An evacuated tube solar collector is theoretically modelled and fabricated with evacuated tube and heat pipe. Optimized parameter for (ETSC) evacuated tube solar collector is evaluated numerically by doing outdoor testing at Coimbatore district Tamilnadu. The time required by this collector to gain the heat is less compared to other collectors. The outlet temperature varies from 50°C to 79°C while the ambient temperature ranges from 24°C to 33°C. The regression analysis is performed to find the best model. Five different models were used to fit the experimental data. The best curve fitting with highest correlation coefficient and lowest value of RMSE(Root Mean Square Error) is obtained using models available in MATLAB. The ETSC is designed and fabricated with the length and diameter of 1.8 and 0.058 m respectively.

KEYWORDS: Evacuated Tube, Heat Pipe, Renewable, Solar Thermal

I. INTRODUCTION

There are different methods to harness the solar energy one such process is the solar thermal collectors which can trap the radiation and convert into thermal energy and transfer it to the working liquid. Flat plate collectors are subjected to heat loss which is minimized in ETC.[1] Evacuated tube consists of two glass tubes made of borosilicate the inner glass tube and outer tubes are separated by vacuum space. The vacuum is a perfect insulator doesn't allow the short wave radiation to escape through vacuum characteristics of trapping radiation is better than other methods. The Evacuated tube collectors have two tubes separated by a vacuum where the radiant energy incident can be directed inside the tube without much heat losses [2]. Heat pipe is a thermal energy absorbing and transferring system with no moving parts which can transfer more energy than copper, where the heat pipes are the best known conductor. Heat pipe can operate with a temperature up to 300° C with 50% to 60% efficiently [3]. The solar radiation incident on the collector of the outer glass the short radiation is incident on the inner tube consists of the heat pipe where the radiation falls on the external surface of the heat pipe and causes the working fluid near the surface to evaporate instantaneously. The vapour thus formed absorbs latent heat of vaporization and this part is evaporator region then vapour travels to other end of pipe causing vapour to condense this part is condenser region giving up the heat (thermal energy) to the manifold where the heat is exchanged with cold fluid passing through the manifold.

II. LITERATURE REVIEW

[5]The author has designed and constructed the heat pipe collector and its performance was calculated both theoretically and experimentally. The gravity assisted heat pipes are used for the experimentation purpose. The theoretical model was developed by NTU method to find the outlet temperature. The author formulated the equations to calculate thermal resistances of the heat pipe with outer wall of evaporation segment to heat pipe ETC. From the developed theoretical model suggest an optimum heated length-cooled length ratio to absorb more heat and increase the overall amount of useful heat. The optimum range of the evaporation to condensation part also discussed L_e/L_c is 8.25 with the $L_e = 1.34\text{m}$ and $L_c = 0.2\text{m}$ respectively for the efficient heat transfer rate. This model is capable to predict some performance characteristics of the solar system, such as heat pipe temperature, water outlet temperature,

International Journal of Innovative Research in Science, Engineering and Technology

(An ISO 3297: 2007 Certified Organization)

Website: www.ijirset.com

Vol. 6, Issue 3, March 2017

efficiency, and useful absorbed heat.

[4] In this paper the author investigated the heat transfer analysis of the Heat pipe Evacuated Tube Solar Collector made of borosilicate glass with length of 1.8m and 0.058m and 0.049m diameter of outside and inside tubes respectively. The heat pipe is made up of copper with length of 1.7m and 0.015m and 0.012m diameter of outside and inside tubes. The thermal losses and useful thermal energy is calculated numerically to investigate the performance of the collector and results show that maximum the solar radiation there will be a increase in outlet temperature and useful thermal energy. The thermal losses are calculated using the thermal resistances. The optical efficiency of the borosilicate glass tube is 72%. . The experimentation was started at the December month and solar radiation recorded as 680 w/m^2 . The maximum temperature was recorded 43°C at the ambient temperature of 21°C and the collector efficiency was 72 % with the low solar radiation. The results obtained from this paper show that heat pipe evacuated tube solar collector is more efficient than ETSC without heat pipe and flat plate collectors. [6]In this paper the author has developed a mathematical model according to the thermal energy and exergy analysis to analyse the performance of the collector and it is tested experimentally. The trend of water temperature changes was increasing when time passes with an increase in solar radiation. In this system the optimum number of collector used is 15 for the domestic water heating system and the maximum temperature was 64°C which occurs at the maximum solar radiation in a day. The effect of mass flow rates on the outer fluid temperature is low at the beginning and at the end of the day. From this analysis the increase in heat pipe collectors increase the temperature and effect of mass flow rates with respect to solar radiation is found. The flow rate with lowest producing more temperature than other flow rates. The numerical and experimental values differ by 8.4 %.

III. DESIGN OF EVACAUTED TUBE SOLAR COLLECTOR

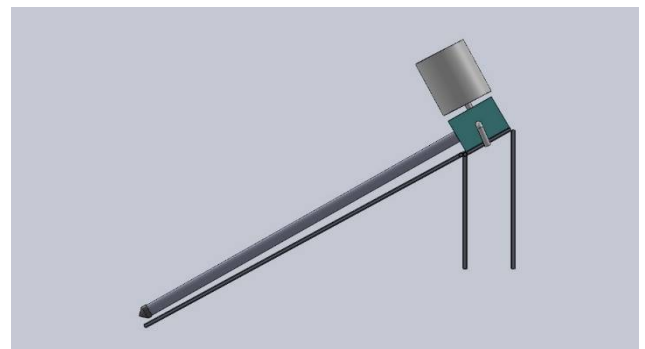
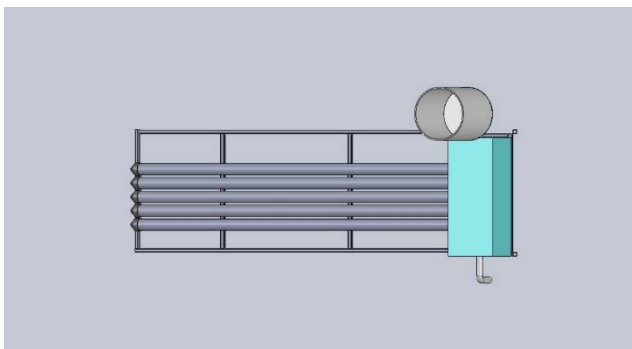
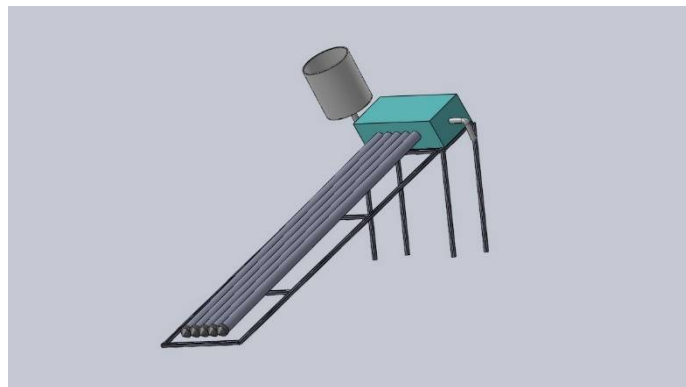

Fig. 1 Designed Solar Collector (a) Front View (b) Top View (c) Right Side View

International Journal of Innovative Research in Science, Engineering and Technology

(An ISO 3297: 2007 Certified Organization)

Website: www.ijirset.com

Vol. 6, Issue 3, March 2017

Mathematical Modelling

The evacuated tube solar collector with heat pipe is modelled. The heat losses in the outer glass and inner glass and at the evaporation and condensation segment are calculated using the thermal resistances. The properties of the heat pipe is given in table 2. The proposed model is shown in fig.1. The collector efficiency is calculated numerically and regression analysis is perform to fit and predict the best model statistically by using the computer program. EXCEL and MATLAB is used to perform the calculations. The Higher the R value lower the RMSE (Root Mean Square Error) value to determine the goodness of fit. The mathematical model for ETSC-HP is developed by forming the thermal resistance network and the heat loss and useful heat is calculated by the thermal resistances. The heat entering the tube is through convection and radiation and transfer of heat through the convection principle. All the convection and radiation losses are calculated and useful heat gained by the collector is known for this the mathematical model is developed.

Table.1 Properties of Collector

Collector	
Type	Evacuated Tube Collector
Material	Borosilicate Glass
Dimensions (D*L)	58 mm Diameter * 1800 mm Length
Glass Thickness	16 mm
Number of Tubes	5
Heat Pipe	
Number of Pipes	5
Material	Copper
Dimensions (D*L)	8 mm Diameter * 1700 mm Length
Working Fluid	Water
Type of Wick	Wickless (Thermo siphon)
Absorber Plate	
Material	Aluminium / SS/ Cu
Emission coefficient	0.065
Absorption coefficient (α)	0.93
Tube Reflection Coefficient	0.08

Table.2 Properties of Heat Pipe

Property	Value
Liquid Density ρ_l	988 kg/m ³
Liquid Viscosity μ_l	0.5588 x 10 ⁻³ Ns/m ²
Surface Tension σ	0.0679 N/m
Vapour Density ρ_v	0.08 kg/m ³
Evaporator Length L_e	1.34 m
Condenser Length L_c	0.3 m
Adiabatic Length L_a	0.04 m
Heat Pipe Total Length L	1.68 m
Gravitational Acceleration g	9.81 m/s ²
Temperature Of Vaporization T_s	49 °C
Latent Heat of Vaporization H	2382.8 KJ/kg

Thermal losses Calculations

- Radiation heat transfer between inner and outer tube

$$h_{o,i} = \frac{\sigma(T_{t,o}^2 + T_{t,i}^2)(T_{t,o} + T_{t,i})}{\frac{1}{\epsilon_{t,i}} + \frac{A_i}{A_o} \left(\frac{1}{\epsilon_{t,o}} - 1 \right)}$$

International Journal of Innovative Research in Science, Engineering and Technology

(An ISO 3297: 2007 Certified Organization)

Website: www.ijirset.com

Vol. 6, Issue 3, March 2017

- Forced convection heat transfer on outer tube by the wind

$$h_{t,wind} = 5.7 + 3.8v$$

- Radiation heat transfer between outer tube and sky

$$h_{t,sky} = \sigma_{\epsilon t,o} (T_{t,o}^2 + T_{sky}^2) (T_{t,o} + T_{sky})$$

- Overall loss coefficient

$$U_t = \frac{1}{A_i} \left(\frac{1}{h_{o,i} * A_i} + \frac{1}{(h_{t,wind} + h_{t,sky}) A_o} \right)$$

Calculation of Thermal Resistances

- Thermal resistance of the outer wall of evaporation segment of the heat pipe ETC

$$R_1 = \frac{\sigma_m}{\pi k_{hp} d_m L_e}$$

- Thermal resistance between the liquid and vapour of the evaporation segment of heat pipe ETC

$$R_2 = \frac{RT_s^2 \sqrt{2\pi RT_s}}{\rho_v h_{fg}^2 \pi d_e L_e}$$

- Thermal resistance between vapour and liquid of the heat pipe

$$R_3 = \frac{RT_s^2 \sqrt{2\pi RT_s}}{\rho_v h_{fg}^2 \pi d_c L_c}$$

- Thermal resistance of the outer wall of the condensation segment of the heat pipe ETC

$$R_4 = \frac{\sigma_m}{\pi k_{hp} d_m L_c}$$

- Thermal resistance of the outer wall of the condensation segment of heat pipe ETC and cold water within manifold

$$R_5 = \frac{1}{h \pi d_c L_c}$$

$$h_{c,i} = 0.728 \left[\frac{g \rho_l (\rho_l - \rho_v) k^3 \lambda}{d_i v_i \Delta T_i} \right]^{1/4}$$

$$\sum R_t = R_1 + R_2 + R_3 + R_4 + R_5$$

International Journal of Innovative Research in Science, Engineering and Technology

(An ISO 3297: 2007 Certified Organization)

Website: www.ijirset.com

Vol. 6, Issue 3, March 2017

- Useful Thermal power received by a heat pipe ETC

$$Q_{\text{thermal}} = \eta_{\text{opt}} I A_{\text{ssa}} - \left(U_t A_i + \frac{1}{Rt} \right) (T_{t,i} - T_a)$$

- Area of Selective absorber surface

$$A_{\text{ssa}} = \pi DL$$

- Collector Efficiency

$$\eta_c = \frac{Q_{\text{thermal}} \times N_t}{I (A_{\text{ssa}} \times N_t)}$$

IV. EXPERIMENTAL METHODS

The Evacuated tube solar collector with heat pipe shown in fig.1 it consists of

- Evacuated Tube Solar Collector
- Storage Tank
- Header Section
- Inlet and Outlet Pipes

The Solar Fluid is considered as the working fluid water is used for the experimental purpose The Experimental setup consists of 5 evacuated tubes with heat pipe with the length of 1.8m and 1.7m respectively. Heat pipe of 1.34m length of evaporator and 0.3m of adiabatic and condenser region. The filling ratio is 30 % which is 6ml the vaporization temperature of the heat pipe is set at 60 C for high temperature applications. The header section is provided with 100 Rockwool Insulation. The solar radiation falls on the outer tube of the evacuated tube causing the liquid in the heat pipe to evaporate and give the latent heat (thermal energy) to the solar fluid and condenses. This process occur on cycle and called as Thermosiphon. The working fluid from the storage tank flow naturally (Natural Siphon) to the header exchanging the heat from the condenser section of the heat pipe and passes through the outlet of the header section. water is used as a working fluids for the experimentation purpose. The performance of the working fluids are analysed in this research. The readings are taken from 09.00 Am to 4.00 pm with the geographical location

- Location – KCT Campus Saravanampatti
- North Latitude - 11° N
- East Latitude - 76° E
- Climate Type - Tropical Wet and Dry
- Mean Sea Level - 411 meters (1349 ft.)

The following equipment's were used for the experimentation purpose and uncertainty is given in table 4

International Journal of Innovative Research in Science, Engineering and Technology

(An ISO 3297: 2007 Certified Organization)

Website: www.ijirset.com

Vol. 6, Issue 3, March 2017

Table. 4. Instruments and its uncertainty

S. No	Instrument	Uncertainty
1	Thermopile Sensor Solar Radiation with PID Controller (Pyranometer)	$\pm 2 \text{ W/m}^2$
2	Thermocouple	$\pm 2 \text{ K}$
3	Anemometer	$\pm 1\%$
4	Mass flow rate	$\pm 0.25\%$



Fig. 3 Fabricated Setup

V. RESULTS AND DISCUSSION

The Temperature variations of the designed solar collector is calculated numerically for 3liters. system. For the prediction of the numerical outlet temperature and efficiency the solar radiation is measured on hourly basis from 09.00 a.m. to 4.00 p.m. The solar radiation data for the Coimbatore location is measured and the analysis is done. The outlet temperature depends upon the solar radiation and Number of tubes. The maximum temperature obtained using this

model is 79°C. The Experimental and theoretical Temperature is compared and shown in fig. 4a. The predicted temperature with respect to solar radiation is presented in MATLAB using the cftool. The collector efficiency for the theoretical and experimental is shown in fig.4c. The statistical regression analysis is performed in the MATLAB software. The best models are calculated based on the three parameters R^2 , RMSE and SSE. For the water based model, the Smoothing Spline model is the best fitted model as shown in Table 6.3 From the best model it is obtained that $R^2=0.9855$, RMSE=1.858, SSE=8.278

Table 5. Modelling Constants

S. No	Model	Constants	R^2	RMSE	SSE
1	Smoothing Spline	P =0.0380612	0.9885	1.858	8.278

The experimentation was done on 14th February 2017 and the maximum temperature recorded was 79°C for the maximum solar radiation of 774 w/m².

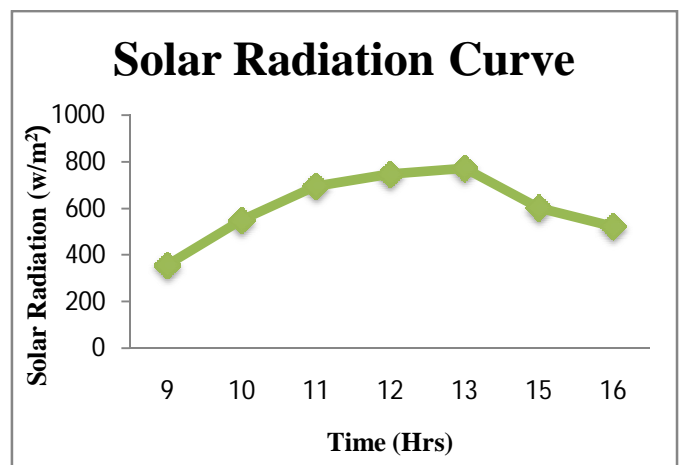
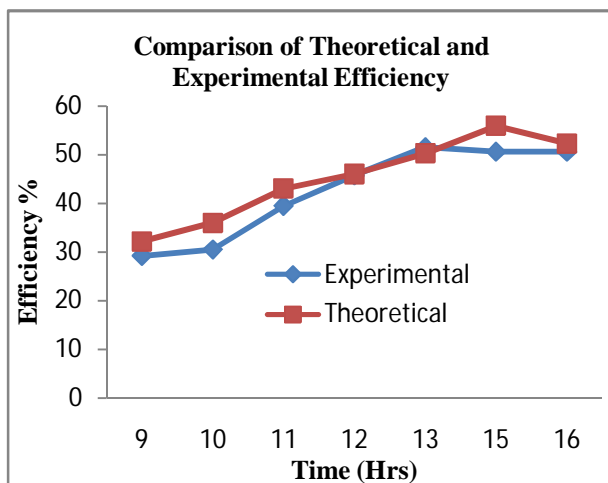
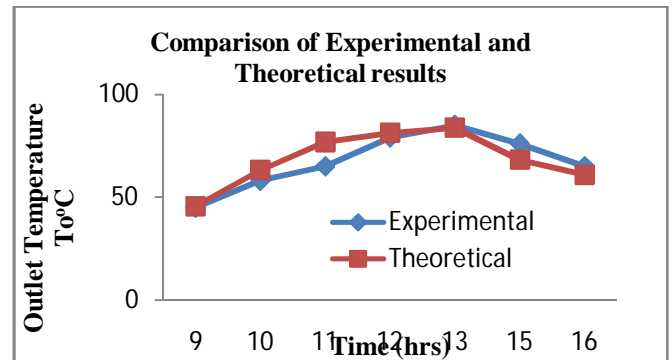
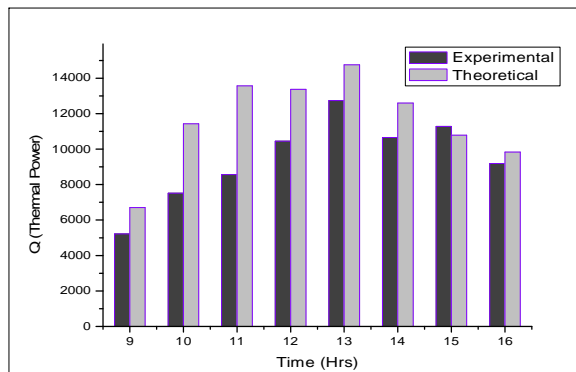

Fig. 4 Results and Discussion (a) Comparison of Experimental and Theoretical Useful Power (b) Comparison of Experimental and Theoretical outlet Temperatures (c) Comparison of Experimental and Theoretical Efficiency (d) Hourly Solar Radiation Curve

International Journal of Innovative Research in Science, Engineering and Technology

(An ISO 3297: 2007 Certified Organization)

Website: www.ijirset.com

Vol. 6, Issue 3, March 2017

VI. CONCLUSION

In this investigation the performance of the Evacuated Tube solar collector with heat pipe is numerically modelled and analysed. In order to explain the behavior the system the mathematical models were selected and correlated. Curve fitting was done in Matlab for both the Experimental and Theoretical results and the best fit smoothing Model.

REFERENCES

- [1] L. J. Shah and S. Furbo, "Vertical evacuated tubular-collectors utilizing solar radiation from all directions," *Appl. Energy*, vol. 78, no. 4, pp. 371–395, 2004.
- [2] Duffie JA and Beckman WA, "Solar Engineering of Thermal Processes, 4th Edition - GearTeam (1)," Wiley, 1991.
- [3] Tiwari G N, "Solar Energy Fundamentals, Modelling, Applications," 1984.
- [4] S. Hlaing and M. M. Soe, "Design Calculation and Heat Transfer Analysis of Heat Pipe Evacuated Tube Solar Collector for Water Heating," vol. 3, pp. 2606–2611, 2014.
- [5] E. Azad, "Theoretical and experimental investigation of heat pipe solar collector," vol. 32, pp. 1666–1672, 2008.
- [6] R. Daghigh and A. Shafieian, "Theoretical and experimental analysis of thermal performance of a solar water heating system with evacuated tube heat pipe collector," 2016.
- [7] M. A. Sabiha, R. Saidur, S. Mekhilef, and O. Mahian, "Progress and latest developments of evacuated tube solar collectors," *Renewable and Sustainable Energy Reviews*. 2015.
- [8] P. L. Paradis, D. R. Rousse, S. Hall, L. Lamarche, and G. Quesada, "Thermal modeling of evacuated tube solar air collectors," *Sol. Energy*, 2015.
- [9] Chunyu Zhao Shijun, You Hao Gao, and W. Yu, "Energy conversion performance investigations for a horizontal evacuated tubular collector," *Int. J. Numer. Methods Heat Fluid flow*, vol. 26, pp. 146–158, 2016.
- [10] B. Abebe and K. Endalew, "Numerical Modelling and Experimental Validation of Heat Pipe Solar Collector for Water Heating," 2011.
- [11] A. Kumar, S. Kumar, U. Nagar, and A. Yadav, "Experimental Study of Thermal Performance of One-Ended Evacuated Tubes for Producing Hot Air," *J. Sol. Energy*, 2013.
- [12] S. P. Vandan, L. P. A. Shunmuganathan, T. Manojkumar, and C. S. Thanu, "Study on Design of an Evacuated Tube Solar Collector for High Temperature Steam Generation," vol. 2, no. 12, pp. 539–541, 2012.
- [13] A. Yadav and V. K. Bajpai, "An Experimental Study on Evacuated Tube Solar Collector for Heating of Air in India," vol. 2, no. AUGUST 2015, pp. 48–53, 2011.