

## International Journal of Innovative Research in Science, Engineering and Technology

(An ISO 3297: 2007 Certified Organization)

Website: [www.ijirset.com](http://www.ijirset.com)

Vol. 6, Issue 3, March 2017

# Survey on Maximum Power Point Tracking for Photovoltaic System Using PIC Microcontroller

Sorate Tushar K<sup>1</sup>, Jadhav Dhiraj D<sup>1</sup>, Solanke Sanjay Y<sup>1</sup>, Prof. Mr. S. D. Mangate<sup>2</sup>

Student, Department of Electrical Engineering, College Of Engineering, Malegaon (Bk), Savitribai Phule Pune  
University, Pune, India<sup>1</sup>

Professor, Department of Electrical Engineering, College Of Engineering, Malegaon (Bk), Savitribai Phule Pune  
University, Pune, India<sup>2</sup>

**ABSTRACT:** This project involves the development of a solar panel to generate direct current (DC) power that will be used to charge a battery. And this DC voltage from battery is converted into AC using inverter. This system will provide the basic electricity requirements for the house. The initial investment may be excessive for the target population; these costs are expected to go down if the design is mass-produced. Solar power source is “free” making this system is a viable long-term solution for electrification. The implementation of a project such as this will make the use of hazardous items such as kerosene lamps and car batteries redundant. Non-conventional power generation is one of the fastest growing sectors. Globally, all countries are busy developing and implementing non-conventional power to bridge the electricity demand and power supply gap. The sun is the ultimate source of limitless solar energy in the form of light and heat. Light of the sun is directly converted into electrical energy without any intermediate step. Solar photovoltaic (PV) power is leading ahead of the other sources. In a solar power generation system, the PV cell plays a major role.

**KEYWORDS:** Photovoltaic panel, MPPT, DC-to-DC converter, Microcontroller, RS485.

### I. INTRODUCTION

Energy is fundamental to the quality of our lives. Nowadays, we are totally dependent on an abundant and uninterrupted supply of energy for living and working. It is a key ingredient in all sectors of modern economies. We use it constantly at home, at work and for leisure. Energy maintains our standard of living and economy. From the time you wake up to the time you go to sleep at night, energy has affected your life. Energy is important in everyone's life, whether you notice it or not. Without it people would have a harder time waking up and an even harder time getting anywhere. Energy is important in many ways like. You wake up to the sound of your alarm clock, in a nice warm home. Energy is important to heat our homes, and most houses have gas, oil or electric heaters. The mechanical energy in a wind up alarm or electric energy in a battery or plug in alarm is important to wake you up. Energy is needed to heat water, which is used when you take a shower or wash your face in the morning. Energy even effects when you put on fresh clothes in the morning. Your clothing were probably made in a factory, which was powered by electricity. Now a days energy has become more important for the collective good than individual's need. Electricity runs like blood through the veins of economy without it the economy will tremble and it will be difficult for it to survive. Taking in account the diminishing natural resource known to mankind it the need of the hour, that someone stood up and discover new horizons explore more possibilities and bring forward new ideas to fulfil the exponentially increasing energy needs of the world's population. Tracking the maximum power point (MPP) of a photovoltaic (PV) array is usually an essential part of a PV system. As such, many MPP tracking (MPPT) methods have been developed and implemented. The

## International Journal of Innovative Research in Science, Engineering and Technology

(An ISO 3297: 2007 Certified Organization)

Website: [www.ijirset.com](http://www.ijirset.com)

Vol. 6, Issue 3, March 2017

methods vary in complexity, sensors required, convergence speed, cost, range of effectiveness, implementation hardware, popularity, and in other respects. They range from the almost obvious (but not necessarily ineffective) to the most creative (not necessarily most effective). In fact, so many methods have been developed that it has become difficult to adequately determine which method, newly proposed or existing, is most appropriate for a given PV system. To maximize a PV module output power, we need to continuously track maximum power point of the system. But the maximum power point depends on the irradiance levels, the panel's temperature, and the load connected. Using a charge controller without MPPT is like connecting the battery directly to the solar module. A traditional charge controller may charge a battery with the voltage that is dictated by battery. Typical VI characteristic of a solar panel is shown in Fig.1

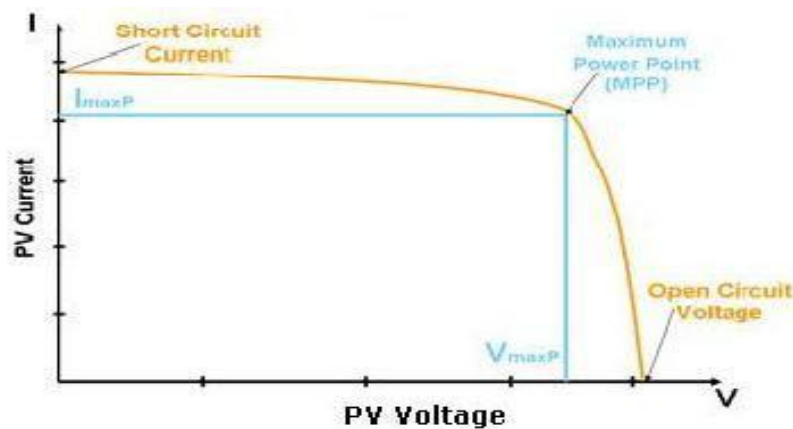

Fig.1 solar panel voltage/current characteristic

## II. LITERATURE SURVEY

This paper [1] presents the analysis, design, and implementation of a parallel connected maximum power point tracking (MPPT) system for stand-alone photovoltaic power generation. The parallel connection of the MPPT system reduces the negative influence of power converter losses in the overall efficiency because only a part of the generated power is processed by the MPPT system. Furthermore, all control algorithms used in the classical series-connected MPPT can be applied to the parallel system. A simple bidirectional dc-dc power converter is proposed for the MPPT implementation and presents the functions of battery charger and step-up converter. This study [2] develops a maximum power point tracking algorithm that optimizes solar array performance and adapts to rapidly varying irradiance conditions. In particular, a novel extreme seeking (ES) controller that utilizes the natural inverter ripple is designed and tested on a simulated solar array with a grid-tied inverter. The new algorithm is benchmarked against the perturb and observe (PO) method using high-variance irradiance data gathered on a rooftop array experiment in Princeton, NJ. To increase the output efficiency of a photovoltaic (PV) generation system it is important to have an efficient maximum power point tracking (MPPT) technique. This paper [3] describes the analysis, design and implementation of an efficient tracking method for a stand-alone PV generation system, which automatically adjusts the reference of output voltage to track the maximum power point (MPP) by using the exponential program. Compared with the conventional constant voltage (CV) method, the proposed approach can effectively improve the tracking speed and accuracy simultaneously. Furthermore, an improved control system is designed for the pulse-width-modulation (PWM) inverter to achieve the objective of MPPT. Theoretical analysis and principle of proposed method are presented and simulation results are given to verify the validity of control method. The many different techniques for maximum power point tracking of photovoltaic (PV) arrays are discussed. The techniques [4] are taken from the literature dating back to the earliest methods. It is shown

# International Journal of Innovative Research in Science, Engineering and Technology

(An ISO 3297: 2007 Certified Organization)

Website: [www.ijirset.com](http://www.ijirset.com)

Vol. 6, Issue 3, March 2017

that at least 19 distinct methods have been introduced in the literature, with many variations on implementation. This paper should serve as a convenient reference for future work in PV power generation.

## III. PROPOSED METHODOLOGY

### Block Diagram

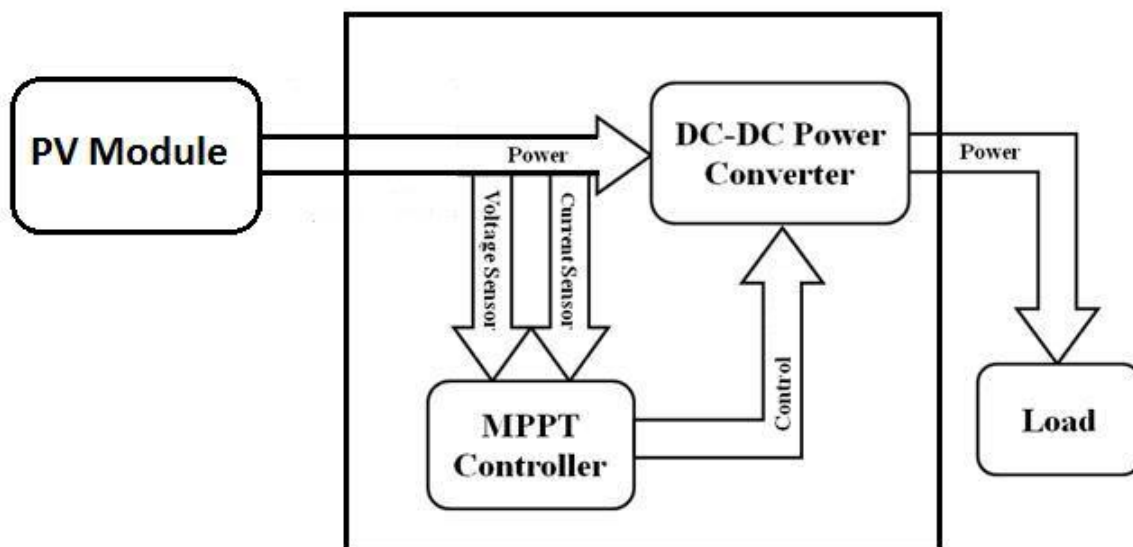

Fig.2 Block Diagram of the proposed system of MPPT.

The overall system block diagram consists of PV panel, charge controller, battery and inverter. The charge controller contains a DC-to-DC converter which matches the PV module voltage to battery voltage. Voltage and current sensors are present to sense the voltage and current and give them to microcontroller. The microcontrollers preprogrammed to operate at maximum power point by using perturb and observe method. The data from the microcontroller can be transmitted to remote location through RS 485 interface. This helps in data logging and monitoring the data from a remote place. The overall block diagram is shown in Fig.2.

### Hardware Design And Description

#### 1. Peripheral interfacing controller

PIC is a low-power CMOS 8-bit microcontroller based on the AVR enhanced RISC architecture. **Features:**

#### Flash feature

- i. Supports operation in industrial and extended temperature ranges
- ii. Fully Static Operation
- iii. Low power, high speed

#### Advanced analog feature

- i. On chip 10 bit, 8-channel analog to digital converter
- ii. 2-analog comparator

#### Peripheral Features

- i. Four 8/16-bit Timer/Counters with Separate Pre scalars and Compare Modes and capture mode and pwm mode
- ii. Three external interrupts

# International Journal of Innovative Research in Science, Engineering and Technology

(An ISO 3297: 2007 Certified Organization)

Website: [www.ijirset.com](http://www.ijirset.com)

Vol. 6, Issue 3, March 2017

- iii. High current sink
- iv. 8-channel, 10-bit ADC
- v. On-chip Analog Comparator

## I/O and Packages

- i. 32 Programmable I/O Lines
- ii. 40-pin PDIP

## 2. LM7805 Voltage Regulator

The LM7805 consist of terminals. First terminal is for the input voltage of specific range. The second terminal is for the ground and third terminal is for the output voltage of 5V.

### Features:

- i. Output current in excess of 1A
- ii. Internal thermal overload protection
- iii. No external components required
- iv. Output transistor safe area protection
- v. Internal short circuit current limit
- vi. Available in the aluminium TO-3 package

## 3. DC-DC Converter

The DC voltage from the panel varies depending on the light intensity, which varies based on the time of the day and solar panel temperature. A DC-to-DC regulator is needed to increase or decrease the input panel voltage to the required battery level . Boost converter is power converter which DC input voltage is less than DC output voltage. That means PV input voltage is less than the battery voltage in system. Buck converter is power converter which DC input voltage is greater than DC output voltage. That means PV input voltage is greater than the battery voltage in system.

## 4. PV Panel

A solar panel (also solar module, photovoltaic module or photovoltaic panel) is a packaged, connected assembly of photovoltaic cells. The solar panel can be used as a component of a larger photovoltaic system to generate and supply electricity in commercial and residential applications.

There are different types of solar panels available but the two most popular technologies used in today's solar energy market are silicon, which is consider a first-generation technology and thin film which is a second-generation technology.

## 5. Battery

The batteries used in photovoltaic MPPT charge controller served as a way to store energy so that devices can be powered in the event that the sun is not shining and when more power is needed than can be provided by the solar arrays at a given time. The battery bank should provide a large energy capacity, run at 12V, and provide a large output current to handle high power loads.

## 6. Inverter

The inverter is the final stage of the system. It is through the inverter that the user has the opportunity to access the power stored in the batteries that was originally generated in the solar panel. The main functionality of the inverter is to take the DC voltage stored in the batteries and transform it into AC voltage that can be used by small household appliances or sent to grid for commercial purpose.

## 7. RS485 Interface

The RS485 interface is responsible for communicating the sensor and performance values to a remote computer over cables. These devices should be able to provide a long enough range for a typical homeowner to be able to receive data from a photovoltaic system located near the house.

## International Journal of Innovative Research in Science, Engineering and Technology

(An ISO 3297: 2007 Certified Organization)

Website: [www.ijirset.com](http://www.ijirset.com)

Vol. 6, Issue 3, March 2017

### 8.Sensors

The implementation of sensors in the charge controller was essential to achieve desired functionality of the system. The sensors are the devices that are going to be in charge of monitoring and communicating everything that was happening in the system to the microcontroller.

### 9. Solar Cell Equivalent Circuit

A photovoltaic array consists of several photovoltaic cells connected in series and parallel. Series connections are responsible for increasing the voltage of the module whereas parallel connections are responsible for increasing the current in the array. Typically a solar cell can be modelled by a current source and an inverted diode connected in parallel to it. The equivalent circuit of solar cell is shown in Fig.3

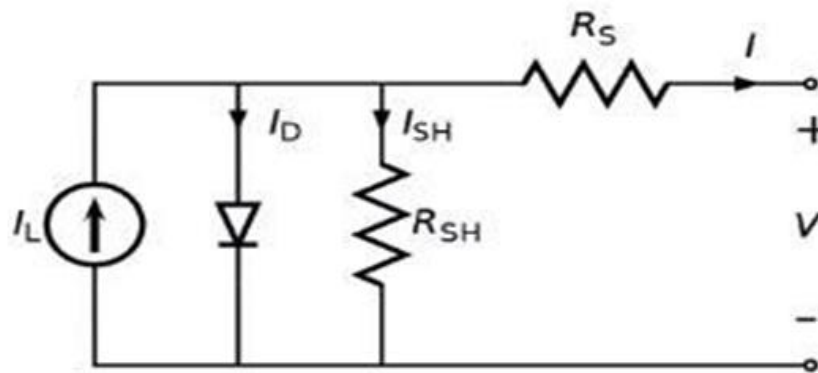

**Fig.3 solar cell equivalent circuit**

The main part of the system is the PV module. The solar panels in all the various makes and models are not very efficient at converting solar energy. So panel performance and means to increase it were very important. Every solar panel has an I-V curve or I-V characteristics associated with it. The area under the I-V curve is approximately the maximum power that that a panel would produce if it would operate at maximum voltage or open-circuit voltage and maximum current or short-circuit current. MPPT is an indirect method of maximizing the efficiency at which the solar panels deliver electricity to an on-grid or off-grid scenario like charging a bank of batteries. The voltage, current, temperature and irradiance levels are sensed by the sensors. The DC-DC converter is responsible for optimizing the output voltage of the panel to match the required voltage level of battery. The DC-DC converter used is the Buck-Boost converter because if the battery requires a lesser voltage from the panel the Buck converter reduces the voltage and if the battery requires more voltage the Boost converter boosts the voltage. Thus the utilization of maximum power from the panel is done effectively. The current, voltage, temperature from the panel and the current and voltage from the DC-DC converter are sensed by the sensors and are given to microcontroller. The Microcontroller is pre-programmed to always output maximum power by using perturb and observe method. Thus the battery is always charged at maximum power. The battery is connected to the inverter where AC to DC conversion takes place. The AC power is utilized for household applications or is sent to grid for commercial purpose.

### IV.CONCLUSION

The MPPT charge controllers can be used to utilize maximum power out of solar panels instead of investing in more number of solar panels. The addition of RS485 interface is the most significant change made to the earlier available system. This helps the user to monitor the data from a remote place. It also helps in data logging. The proposed idea can be further upgraded by incorporating wireless technology so that we can wirelessly transmit the data.



ISSN(Online): 2319-8753  
ISSN (Print): 2347-6710

# International Journal of Innovative Research in Science, Engineering and Technology

(An ISO 3297: 2007 Certified Organization)

Website: [www.ijirset.com](http://www.ijirset.com)

Vol. 6, Issue 3, March 2017

## REFERENCES

- [1] R. Gules, J. De Pellegrin Pacheco, H. L. Hey, and J. Imhoff, "A maximum power point tracking system with parallel connection for PV stand-alone applications," IEEE Trans. Ind. Electron., vol. 55, no. 7, pp. 2674---2683, Jul. 2008.[1]
- [2]V. Quaschnig and R. Hanitsch, "Influence of shading on electrical parameters of solar cells," in Proc. 25th IEEE Conf. Record Photovoltaic Spec. Conf., May 1996, pp. 1287–1290
- [3]Liu Liqun , Wang Zhixin, "A variable voltage MPPT control method for photovoltaic generation system, WSEAS Transactions on Circuits and Systems", v.8 n.4, p.335-349, April 2009
- [4]T. Eswam and P. L. Chapman, "Comparison of photovoltaic array maximum power point tracking techniques," IEEE Trans. Energy Convers., vol. 22, no. 2, pp. 439–449, Jun. 2007.