

Wireless Sensor Network Based Auto Controlled Engine for Railway

Mohamed Waseem Paravengal¹, Dimiljose²PG Student, Dept. of ECE, Cochin College of Engineering and Technology, Valanchery, Kerala, India¹Asst. Professor, Dept. of ECE, Cochin College of Engineering and Technology, Valanchery, Kerala, India²

ABSTRACT: Railway transportation is the one of the major transportation in our country. It provide several benefits over other, but the railway authority not provided a proper safty system in the railway infrastructure. Only a manual inspection is provided ,so that no of accidents increasing day by day. We are not get proper inspection from railway track. To prevent the accidents we plan a wireless sensor network to prevents the accidents by monitoring railway track, wheel ,rail bridges and wagon using multi sensor unit with wireless zigbee. Here we use auto controlled train engine for avoid accidents in abnormal level, if any of the sensor unit is abnormal like crack detector or object detector in the track, then the server PC collecting all data from sensor unit and give command for particular train for control engine motor to stop train automatically.

KEYWORDS : Crack detection, zigbee, ultrasonic test, proximity sensor

I.INTRODUCTION

In our country we are hearing about the accidents in the train due to we are not getting proper inspection from railway track by the railway authority, that may end human life. To prevent train accidents plan to go for the intelligent wireless sensor network to prevent accident avoiding system in train. The objective of this project to monitor and control railway infrastructure such as railway tracks, cracks, wheel, rail bridges and tunnels using multi sensor unit with wireless ZigBee. Condition monitoring reduces the human inspection requirement through automated monitoring reduces maintenance through detecting faults before they escalate and improve safety and reliability. this is a vital for development, upgrading, expansion of railway network.The objective of this project is to monitor the railway tracks, cracks, wheel, rail bridges, tunnels using multi sensor unit with wireless ZIGBEE technology.The new Wireless sensor networks (WSNs) are wireless networks of spatially distributed and autonomous devices. They used to measure several atmospheric and environmental conditions in the railway infrastructure to provide automatic inspection in the railway system. The sensors need to be carefully located to ensure their measurements are useful and do not replicate the measurements of other sensors, which can skew the distribution of the collected data. The type of sensor used needs to be carefully considered to ensure the maximum value and the best quality data. WSNs can use a set of homogeneous or heterogeneous sensors. Sensors are often located away of local energy generation to power them. If there are errors in transmission across the WSN, then data may be missing.

II.RELATED WORK

The Long Range Ultrasonic Testing (LRUT) technique[1] is complimentary inspection technique to examine the foot of rails, especially in track regions where corrosion and associated fatigue cracking is likely, such as at level crossings. LRUT technique is found to be suitable for examining inaccessible areas of railway tracks such as areas where corrosion occurs and susceptible areas of fatigue cracking. A suitable array of transducers is developed that is able to generate selected guided wave modes in rails which allow a reliable long range inspection of the rail. The characteristics of ultrasonic guided waves in the rail complex geometrical profile have been identified. An algorithm for crack detection in rail tracks is uses Light Emitting Diode and Light Emitting Resistor (LED-LDR) assembly which

International Journal of Innovative Research in Science, Engineering and Technology

(An ISO 3297: 2007 Certified Organization)

Website: www.ijirset.com

Vol. 6, Issue 5, May 2017

tracks the exact location of faulty track. The design includes LED which are attached to one side of the rails and the LDR to the opposite side. When there are no cracks i.e. during normal operation, the LED light does not fall on the LDR and hence the LDR resistance is high. Subsequently, when the LED light falls on the LDR, the resistance of the LDR gets reduced and the amount of reduction will be approximately proportional to the intensity of the incident light. Consequently the light from the LED deviates from its path due to the presence of a crack or a break and there is a sudden decrease in the resistance value of the LDR.

Most of the Railway Track defects which lead to derailment are detected manually by trained human operators walking along the track. To overcome this difficulty, an Automatic Railway Track Derailment Inspection System using Machine Vision Algorithm [2] to detect the cracks in the railway track is proposed here. The input image is decomposed by Gabor filter and texture features were extracted using Segmentation based Fractal Texture Analysis (SFTA) and the features are classified as defect and defect free classes using AdaBoost Classifier. The proposed algorithm is tested on a set of real time samples collected and the classification rate obtained was satisfactory.

III.SENSOR DESIGN

There are a multitude of sensors types used in railway condition monitoring for analyzing different aspects of structures, infrastructure, and machinery Transducers convert energy from one form to another. In the case of sensors, the device typically converts a measured mechanical signal into an electrical signal. Most railway sensors fall under the umbrella type micro electro mechanical systems (MEMS). MEMS are small, integrated devices, or systems that combine electrical and mechanical components. They are cheap and efficient .Sensor design requires a tradeoff between functionality and power consumption, with functionality often coming at the cost of power. Condition monitoring systems for railways are often deployed in remote or inaccessible locations, where there is no wired power supply available. Hence, the sensors must receive power from either batteries or local energy generation. MEMS sensors have the advantage that they can be produced to consume ultralow power.

IV.NETWORK DESIGN

WSNs enable continuous real-time capture of data. However, WSNs need to be able to handle the harshness of outdoor long term condition monitoring; often in hostile environments and must minimize energy usage as the nodes are not attached to a wired power supply. They typically use low-power sensors powered by batteries although authors are investigating alternative power supplies such as local energy generation. Hence, the network to enable data capture has to be carefully designed to overcome these factors and prevent transmission errors, latency, network outages, missing data, or corrupted data. The base station controls the sensor nodes and acts as a gateway for data transmission to a remote server. The sensor nodes use short-range communication such as Wi-Fi or Bluetooth to transmit data to the base station. The base station uses long range communication such as GPRS or satellite to transmit collated data back to a server at a control center. It has a more powerful processor and more memory than the sensor nodes to allow it to collate data from multiple sensors. Hence, the base station requires more power. For example, train monitoring systems have battery-powered sensor nodes in the carriages but place the base station in the locomotive, where more power is available from the train engine.

V.COMMUNICATIONS MEDIUM

There are many communication techniques used in WSNs in railway. Inter sensor communications and sensor to base station transmission are usually short range. The base station transmits gathered data back to the control center, and this requires long-range communication. WSNs can use technologies based on standard mobile telephony (Bluetooth, GSM, GPRS, and UMTS) or broadband techniques such as Wi-Fi (IEEE 802.11, 2007), wireless personal area networks (WPANs) (IEEE 802.15.4 and ZigBee [11]) or WiMax(IEEE 802.16.2, 2004). ZigBee enhances IEEE 802.15.4 by including authentication, data encryption for security, and data routing and forwarding. Mobile telephony and WiFi are peer to-peer only, whereas WPANs and WiMax can connect many devices in a mesh topology, where any node can communicate with any other node. In addition, Wi-Fi, WPANs and WiMax allow communication at much

International Journal of Innovative Research in Science, Engineering and Technology

(An ISO 3297: 2007 Certified Organization)

Website: www.ijirset.com

Vol. 6, Issue 5, May 2017

higher speeds and bandwidths than mobile telephony and are cheaper to set up. However, mobile telephony has better coverage and range than Wi-Fi and WPANs. WiMax can operate over long distances. However, there is a tradeoff: either high bitrates or long distances but not both. An important recent communication advance has been GSM-R (Global System for Mobile Communications-Railway), which is an adaptation of GSM telephony for railway applications. It is designed for information exchange between trains and control centers. Its main advantages are its low cost and worldwide availability. Another common technique for railways is the radio system Terrestrial Trunked Radio, which is a standard for data communication.

VI.BLOCK DIGRAM

The PIC 16F877A is the major components of a wireless sensor network for condition monitoring in railway industry. It consist of three separate parts .They are railway track side unit ,Train side unit, and server unit. The objective of this project is to monitor the railway tracks, cracks, wheel, rail bridges, tunnels using multi sensor unit with wireless ZIGBEE technology,different type of sensors used in the project they are crack detect sensor, object sensor ,proximity sensor and ultrasonic sensor. The brief description of each component explained below.For detecting cracks on the railway track by using IR sensors Infrared transmitter is one type of LED which emits infrared rays generally called as IR Transmitter. Similarly IR Receiver (photo diode) is used to receive the IR rays transmitted by the IR transmitter. One important point is both IR transmitter and receiver should be placed straight line to each other. When IR transmitter passes the rays to receiver, the IR receiver is conducting due to that non inverting input voltage is lower than inverting input. Now the comparator output is -12V so the transistor is cutoff region.

We have used IR sensor for detect the objects. Infrared transmitter is one type of LED which emits infrared rays generally called as IR Transmitter. Similarly IR Receiver (photo diode) is used to receive the IR rays transmitted by the IR transmitter. One important point is both IR transmitter and receiver should be placed straight line to each other. When IR transmitter passes the rays to receiver, the IR receiver is conducting due to that non inverting input voltage is lower than inverting input. Now the comparator output is -12V so the transistor is cutoff region. The 5v is given to 40106 IC which is the inverter with buffer. The inverter output is given to microcontroller or PC. This IR circuit is mainly used to for counting application, intruder detector etc.

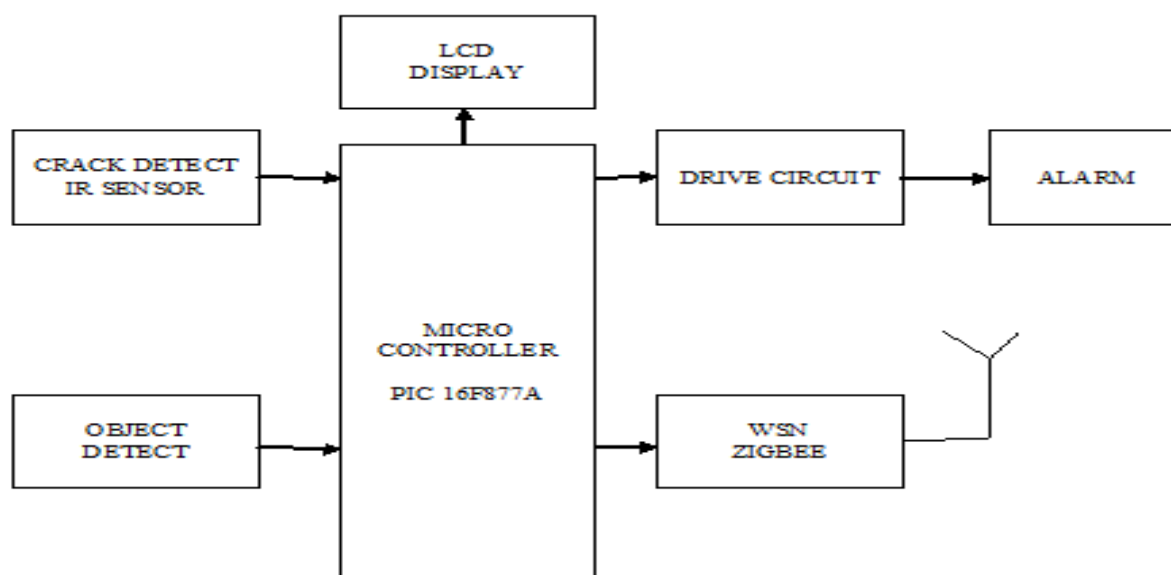

Fig.1 Railway Track Side

International Journal of Innovative Research in Science, Engineering and Technology

(An ISO 3297: 2007 Certified Organization)

Website: www.ijirset.com

Vol. 6, Issue 5, May 2017

ultrasonic sensor the transmitter always passing the rays in the air and the receiver always receive the signals from the reflected waves. The ultrasonic wave is spread in the air and hit the nearest object and reflected from the object which is received by the ultrasonic receiver. The received wave is given to amplifier in order to amplify the received weak signal. After the amplification the amplified wave is given to zero adjustment amplifier because the amplified wave is in the range of above 6v level. Then the output is given to comparator in which the wave signal is converted into corresponding square wave signal.

The proximity sensor is used to find the wheel movement and its find if any problem in wheel Proximity sensors are sensors able to detect the presence of nearby objects without any physical contact. A proximity sensor often emits an electromagnetic or electrostatic field, or a beam of electromagnetic radiation (infrared, for instance), and looks for changes in the field or return signal. The object being sensed is often referred to as the proximity sensor's target. Different proximity sensor targets demand different sensors. For example, a capacitive or photoelectric sensor might be suitable for a plastic target; an inductive proximity sensor requires a metal target. There are four fundamental type of proximity sensors inductive, capacitive, ultrasonic and optical proximity sensor.

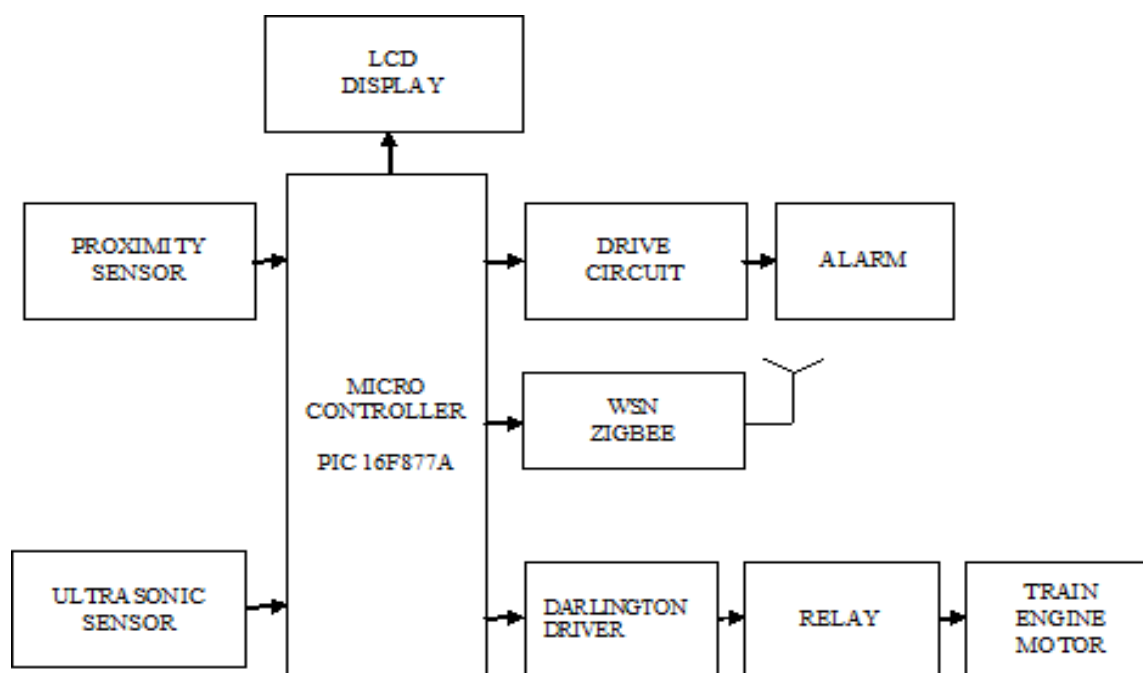

Fig.2 Train Side Unit

In this project work relay and relay driver is used for the function of auto controlled train engine ,the relay is a electromagnetic switch is used with driver circuit for that prpose.A relay is an electrically operated switch,many relay use an electromagnet to mechanically operate a switch.Magnetic latching relays require one pulse of coil power to move their contacts in one direction and another redirected pulse to move them back,repeated pulses from the same input have no effect..A relay driver circuit is a circuit which can drive or operate a relay so that it can function appropriately in a circuit,the driver relay can then operate as a switch in the circuit which can open or close according to the needs of the circuit and its operation,the various type of relay driver ICs are high side toggle switch driver,low side toggle switch driver ,darlington transistor driver and bipolar NPN transistor.

International Journal of Innovative Research in Science, Engineering and Technology

(An ISO 3297: 2007 Certified Organization)

Website: www.ijirset.com

Vol. 6, Issue 5, May 2017

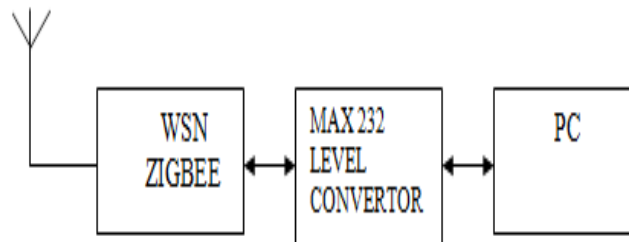

Fig.3 Zigbee and PC interface

In this project we have used RS232 for communicate the microcontroller and PC. In telecommunications, **RS-232** is a standard for serial binary data interconnection between a *DTE* (Data terminal equipment) and a *DCE* (Data Circuit-terminating Equipment). It is commonly used in computer serial ports. In this circuit the MAX 232 IC used as level logic converter. The MAX232 is a dual driver/receiver that includes a capacitive voltage generator to supply EIA 232 voltage levels from a single 5v supply. Each receiver converts EIA-232 to 5v TTL/CMOS levels. Each driver converts TLL/CMOS input levels into EIA-232 levels.

VII.SIMULATION AND RESULTS

The figure bellow shows (fig 4) the separate parts of hardware modules that is the railway train side unit, track side unit and server control unit .the pic controller is the heart of this work, here two different voltage power supply's are used 5v and 12v., the serial to usb cable is used for interfacing with pc.



Fig.4 Three separate Hardware modules

Component were purchased according to our proposed design and connected in bread board for testing. After the correction and modification we mounted it in the PCB, the working model was tested ,consist of three hardware units ,One is railway track side, second is train side and last one is server unit side. switch on the power supply the sensor units monitor the appropriate sides ,and its monitored by server PC, the track side sensors monitor continuously the railway track, if any crack is present in the track then the crack detect IR sensor finds the crack using microcontroller and inform to server side PC using ZIGBEE technology. Same microcontroller enables the alarm to indicate us.

International Journal of Innovative Research in Science, Engineering and Technology

(An ISO 3297: 2007 Certified Organization)

Website: www.ijirset.com

Vol. 6, Issue 5, May 2017

VII.CONCLUSION AND FUTURE WORK

A broad range of sensors are used in railway monitoring to provide an extensive range of data and allow monitoring of different structures, monitor the railway tracks, cracks, wheel, rail bridges, tunnels using multi sensor unit with wireless ZIGBEE technology. The main challenge for WSNs in railway applications is determining the best measurement technologies to use. The WSN must be reliable and accurate to enable effective condition monitoring in harsh and in accessible environments but must also be cost effective. Here use auto control train engine for avoid accident in abnormal level. If anyone of the sensor unit is abnormal like crack detect or any object (stone or animals etc) in the track or both trains or in the same track. Then the server PC collecting all data from sensor unit and give command to particular train for control engine motor to stop train automatically for avoid accident.

REFERENCES

- [1] B. Ai *et al.*,(2014) "Challenges toward wireless communications for high-speed railway," *IEEE Trans Intell. Transp. Syst.*, vol. 15, no. 5, pp. 2143–2158.
- [2] J. Chen *et al.*,(2013) "RAISE: RAILway infrastructure health monitoring using wireless sensor networks," *Sens. Syst. Softw.*, vol. 122, pp. 143–157.
- [3] E. Berlin and K. van Laerhoven,(2013) "Sensor networks for railway monitoring: Detecting trains from their distributed vibration footprints," in *IEEE Int. Conf. Distrib. Comput. Sens. Syst.*, Cambridge, MA, USA, ,pp. 80–87.
- [4] G. Feltrin, Berlin, (2012) "Wireless sensor networks: A monitoring tool for improving remaining lifetime estimation," in *Civil Struct. Health Monitoring Workshop*, pp.
- [5] V. Casolaet *al.*,(2012)"Freight train monitoring: A case-study for the pSHIELD project," in *Proc. 6th Int. Conf. Innov. Mobile Internet Serv.UbiquitousComput.*, Palermo, Italy, 597–602.
- [6] K. Bollas, P. Dimitrios, K. Dimitrios, and A. Athanasios,(2010)"Acoustic emission inspection of rail wheels," *J. Acoust. Emission*, vol. 28, pp. 215–228,
- [7] P. Bennett *et al.*,(2010)"Wireless sensor networks for underground railway applications: Case studies in Prague and London," *Smart Struct. Syst.*, vol. 6, no. 5/6, pp. 619–639, .
- [8] M. Boccione, G. Bucca, A. Cigada, A. Collina, and L. Comolli,(2010) "An application of FBG accelerometers for monitoring pantographs of underground trains," in *Proc. SPIE 4th Eur. Workshop Opt. Fibre Sens.*, Porto, Portugal, pp. 765341-1–765341-4
- [9] P. Boffiet *al.*,(2009) "Optical fiber sensors to measure collector performance in the pantograph-catenary interaction," *IEEE Sens. J.*, vol. 9, no. 6, pp. 635–640, Jun. 2009.
- [10] B. Brickleet *al.*,(2008) "Identification of Existing and New Technologies for Wheelset Condition Monitoring," TTCI Ltd., London, U.K., RSSB Rep. Task