

Comparative Study on Capacitive Pressure Sensor for Structural Health Monitoring Applications

Shivaleela.G¹, Dr. Praveen. J², Dr. Manjunatha. DV³, Dr. Habibuddin Shaik⁴

P.G. Student, Department of Electronics & Communication Engineering, Alva's Institute of Engg. & Technology, Mijar, Moodbidri, Karnataka, India¹

Dean Academic, Department of Electronics and Communication Engineering, Alva's Institute of Engg. & Technology, Mijar, Moodbidri, Karnataka, India²

HOD, Department of Electronics and Communication Engineering, Alva's Institute of Engg. & Technology, Mijar, Moodbidri, Karnataka, India³

Assistant Professor, Department of Physics, Nitte Meenakshi Institute of Technology, yelahanka, Bangalore, Karnataka, India⁴

ABSTRACT: This paper is mainly focuses on the development of a capacitive pressure sensor device for structural health monitoring applications for higher sensitivity. One amongst the strategies to measure vibrations is to mount a pressure sensor on the vibratory machinery or object and measure the pressure exerted owing to vibrations. Therefore this measured physical phenomenon's helps us to notice any deviations from the conventional conditions. The MEMS based capacitive pressure sensors are gained plenty of attention within the market owing to its advantage over MEMS based piezoresistive pressure sensors like low power consumption, high sensitivity, IC compatibility, free from a temperature effects, etc. In this work, the MEMS based capacitive pressure sensor having a versatile square diaphragm of length $10,000\mu\text{m} \times 10,000\mu\text{m}$ with thickness of $525\mu\text{m}$ using 1-spring, 4-springs and 9-springs at each corner is designed and simulated using Finite Element Method (FEM) with minimum element size of $1.5\mu\text{m}$. Also the comparisons between the same three models are done in order to analyze the better sensitivities among them. The typical external pressure ranges between 1Pa to 10,000Pa is applied on the flexible diaphragm. The simulation analysis of mechanical and electrical behavior of the capacitive pressure sensor is done using MEMS CAD tool as COMSOL MULTIPHYSICS. During Comsol Multiphysics analysis, a displacement of $1.57\text{e-}4\mu\text{m}$ at 1Pa pressure and capacitance sensitivity of $5.12\text{e-}14\text{F/Pa}$ was observed for 9-springs capacitance pressure sensor which is a better sensitivity as compared to 1-spring and 4-springs capacitive pressure sensor.

KEYWORDS: MEMS, Capacitive Pressure Sensor, springs, Sensitivity, Comsol Multiphysics.

I. INTRODUCTION

Nowadays MEMS based mostly pressure sensor device has gained tremendous benefits like low power consumption, high sensitivity, low-cost, etc. Hence it is necessary to understand the precise definition of MEMS and its types. Micro-Electro Mechanical Systems (MEMS) is a technology that shows evident exponential growth from last two decades in terms of device miniaturization as its feature size varies in micrometer range. MEMS devices has several applications within the field of bio-medical, automobile, microphones, communication, smart systems, underground

International Journal of Innovative Research in Science, Engineering and Technology

(An ISO 3297: 2007 Certified Organization)

Website: www.ijirset.com

Vol. 6, Issue 5, May 2017

oil explorations etc. [1]. Attributable to the recent improvement within the microscale fabrication technology, MEMS pressure sensors are being fictitious for the pressure levels starting from ultra-low to extraordinarily high. The micro-fabrication technology has become the key to the success of microelectronics and microchips. In modern fabrication technique, a metal diaphragm pressure sensor device is replaced by a silicon semiconductor and compound material. Different kinds of sensing mechanisms utilized in MEMS pressure sensor devices are capacitive, piezoelectric, piezoresistive etc.

The piezoresistive sensors are thought-about because the first micro-machined yield to be mass created and these pressure sensors are extremely temperature sensitive and high power consumption [3]. Thus piezoresistive sensors don't seem to be used for high temperature applications. The capacitive-pressure detector is meant for measuring of each absolute and differential pressures due to that they need gained a lot of attention. They even have the advantage of high pressure sensitivity, low power consumption, less elementary noise floor and low temperature sensitivity. Additionally to those, it has high frequency permeability, compactness, low cost, ease to fabricate, smaller volume and high resolution [1].

A capacitor is an electrical device which stores electric charge in it. It is created from two conducting parallel plates separated by an insulator material like air, ceramic or any insulating materials. In general, MEMS based mostly capacitive pressure sensors are designed using two parallel plates during which the top plate consists of a thin versatile membrane which is referred as diaphragm and therefore the bottom plate is fixed or vice versa. These two plates are separated by an insulator material like vacuum or air. Once the outside pressure is impinged on the diaphragm, it deforms the diaphragm thereby ever-changing the gap between the plates and therefore the capacitance changes [2]. The sensitivity of the capacitive-pressure sensors directly depends on the structure and materials used.

II. RELATED WORK

Many capacitive pressure sensors were designed, analyzed and developed to measure the absolute pressures. The Square diaphragm pressure sensor with length $1500\mu\text{m} \times 1500\mu\text{m}$ and separation gap between the top and bottom diaphragm was $196\mu\text{m}$ was demonstrated [3]. The thickness of the diaphragm was $4\mu\text{m}$ with a center boss structure of diameter $150\mu\text{m}$ and thickness of $1\mu\text{m}$. The external pressure ranges from 10 kPa to 120 kPa had been applied on the diaphragm. The deflection sensitivities observed for the given range for normal diaphragm and bossed diaphragm was $2.02\mu\text{m/kPa}$ and $2.94\mu\text{m/kPa}$. The design analysis is done using Comsol Multiphysics tool, that involves simulation results and performance analysis of MEMS based capacitive pressure sensor using springs with square diaphragm.

III. MATHEMATICAL BACKGROUND OF CAPACITIVE PRESSURE SENSOR

Pressure measurement is considered as one of the most significance parameter in any processes. This section will first explain the basic physics of sensing the pressure. Before describing the background history of capacitive pressure sensor, it is necessary to understand the working principle of basic traditional pressure sensors [5].

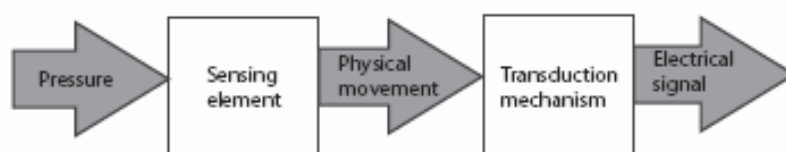

Fig. 1 Block Diagram of pressure sensor

The capacitive pressure sensing element is designed using two parallel plates during which the upper plate is a thin and versatile membrane known as diaphragm and therefore the lower plate is fixed. The two plates are separated by the

International Journal of Innovative Research in Science, Engineering and Technology

(An ISO 3297: 2007 Certified Organization)

Website: www.ijirset.com

Vol. 6, Issue 5, May 2017

insulator material like air. Basically the MEMS capacitive pressure sensing element consists of three main modules. First is, the polysilicon substrate diaphragm acts as a pressure device and sensing element vary is vital parameter for choosing the fabric of the diaphragm. Second module is variable plate capacitor component, where the capacitance will change linearly and reversely with the distance between two plates ($\Delta C = \epsilon_0 \epsilon_r \cdot A/g$). Last module is the electronic part; where it will give the electrical output which is proportional to the pressure input signal. The diaphragm behaviour is especially depends upon edge conditions and therefore the deflection vary as compared to the thickness of the diaphragm. As far as the induced stress for applied pressure is worries the square diaphragm has the best induced stress and thus it is the preferred geometry for the pressure sensors. The schematic of cross sectional view of capacitive pressure sensor is shown in Fig. 2.

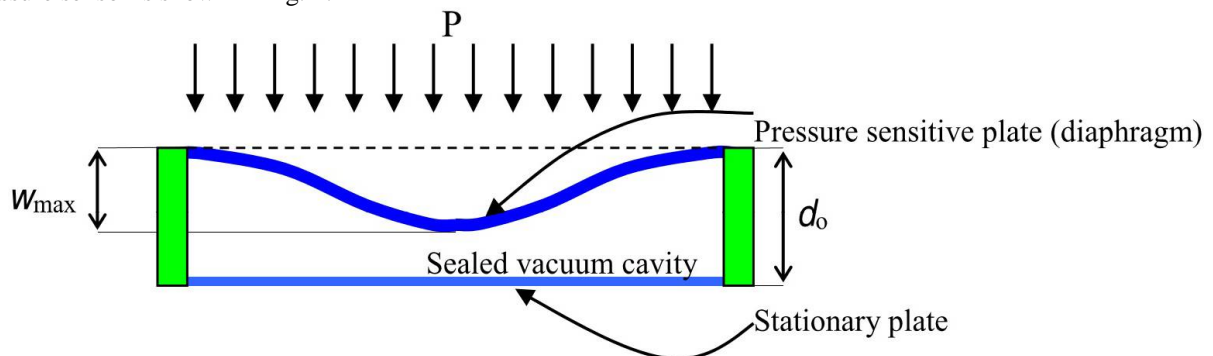

Fig.2 Cross sectional view of capacitive pressure sensor

For a square diaphragm pressure sensor, the change in capacitance due to displacement is given by [6]

$$\Delta C = [0.01512(1-\nu^2) \frac{PL^4}{Eh^3}] [\epsilon_0 \epsilon \frac{A}{d^2}] \quad \dots\dots(1)$$

Capacitance can be calculated using the formula

$$C = C_0 (1 + \frac{12.5pL^4}{2025dh}) \quad \dots\dots (2)$$

Where ΔC = change in the capacitance, ϵ = permittivity, ν = poisson's ratio, a = area, E = young's modulus, h = thickness of diaphragm, d = gap between two plates and p = pressure applied, C_0 = initial capacitance used.

Sensitivity: Sensitivity of the any flexible diaphragm can be defined as the rate of change of the capacitance with respect to the change in the pressure exerted on the diaphragm.

Sensitivity is given by

$$S = \frac{\Delta C}{\Delta P} \quad \dots\dots (3)$$

IV. DESIGN METHODOLOGY

This section explains the modeling of MEMS capacitive pressure sensor using COMSOL Multiphysics tool. In Comsol tool, the MEMS based mostly capacitive pressure detector works on the principle of Electromechanics physics. Once the uniform external pressure is applied on the diaphragm, it causes displacement. Thus the gap between two plates is changes. As the applied external pressure is removed, the diaphragm will get back to its original position [3].

International Journal of Innovative Research in Science, Engineering and Technology

(An ISO 3297: 2007 Certified Organization)

Website: www.ijirset.com

Vol. 6, Issue 5, May 2017

MODELING OF SENSOR IN COMSOL MULTIPHYSICS TOOL:

The COMSOL MULTIPHYSICS is one of the user friendly MEMS CAD tool with a 3D model builder that provides a full summary of the designed model. The tool is employed here for the analysis of MEMS capacitive pressure sensing element. Here Electromechanics interface that may be a built-in physics in COMSOL is employed and a stationary study analysis is completed. The upper top plate is freely moveable and the bottom plate is mounted. The boundary load is applied at the upper top plate with a uniform external pressure of 1Pa. The top and bottom plates are separated by an insulator material as air.

Similarly, for an electrostatic analysis a bias voltage of 1V is applied to the top electrode plate and the bottom electrode plate is grounded. Between two plates i.e. upper and lower plates the springs at every corner of the square diaphragm is employed. Here 1-spring and 4-spring models are proposed in order to compare the higher capacitance sensitivity with the 9-springs capacitive sensor. There are 9-spring elements are used in the design and hence there are total 36-spring are settled in all the four corners of the square plate with the peak of 80 μ m and width of 20 μ m. The springs are employed in the design to avoid a pull-in impact. Apart from this, it is also have an advantage to sense the vibrations in the diaphragm.

- 1. Capacitive pressure sensor with 1-spring:** Here the capacitive pressure sensor with 1-spring is designed and its modeled geometry is shown in Fig. 3. The springs are attached at every corner of the diaphragm. Platinum is the material used for the spring elements.

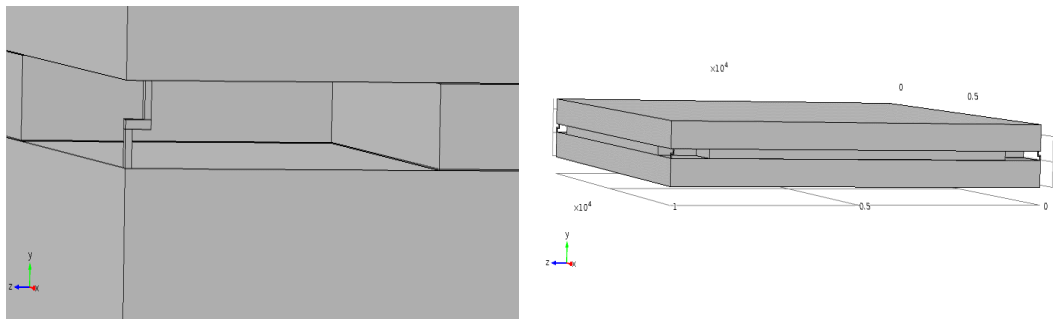

Fig.3 Modeled geometry of capacitive pressure sensor with 1-spring attached

- 2. Capacitive pressure sensor with 4-springs:** The capacitive pressure sensor with 4-springs is attached at every corner of diaphragm membrane. The modeled geometry of capacitive sensor with 4-springs is shown in Fig.4. As the number of springs increased, the zero gap problem occurred within the parallel plate capacitor can be minimized.

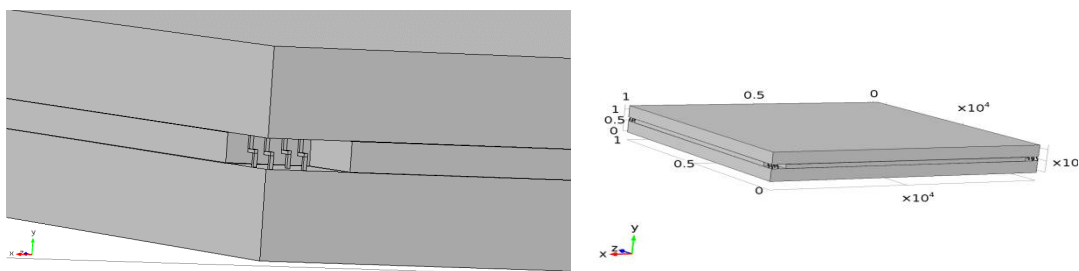

Fig.4 Modeled geometry of capacitive pressure sensor with 4-springs attached

International Journal of Innovative Research in Science, Engineering and Technology

(An ISO 3297: 2007 Certified Organization)

Website: www.ijirset.com

Vol. 6, Issue 5, May 2017

- 3. Capacitive pressure sensor with 9-springs:** The 9-spring capacitive pressure sensor is modeled. The model geometry of 9-springs capacitive pressure sensor is shown in Fig. 5. Here, the single crystalline silicon is used as a material having a relative permittivity (ϵ) of 11.7, young's modulus (E) of 170 GPa, Poisson's ratio (μ) of 0.28 and density (ρ) of 2329 kg/m³. Silicon is used due to its high melting point, less mechanical hysteresis and low thermal expansion coefficient.

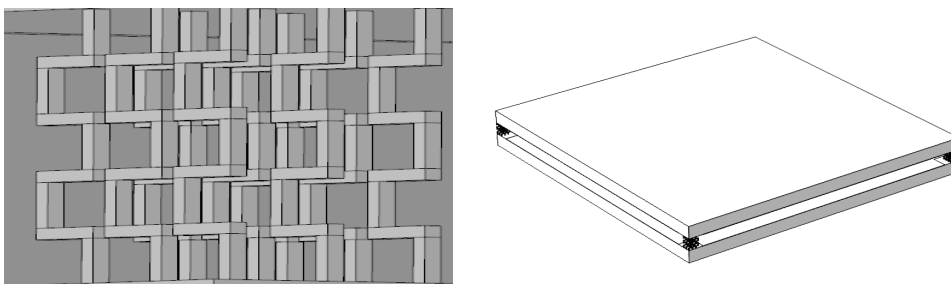

Fig. 5 Modeled geometry of capacitive pressure sensor with 9-springs attached

The table 1 shows the different device layers, materials and the dimensions used during the modeling of capacitive pressure sensor structures.

Table 1: Device dimensions of 1-spring, 4-spring and 9-spring capacitive pressure sensors

Layers	Materials	Size [um]	Thickness[um]
Top and bottom plate	Silicon	10000x10000	525
Top and bottom electrode	Platinum	9500x9500	2
Air block(gap b/w 2 plates)	Air	9500x9500	180
Springs	platinum	80	20

In order to hold out electrostatic study to get capacitance values a platinum electrode plate has been deposited over top and bottom plates whose dimensions are given in table 1 and Fig. 6 (a) shows the various device layers. The FEM analysis was dispensed with a minimum element size of 1.5 μ m. The meshed model of capacitive pressure sensor is shown in the Fig.6 (b).

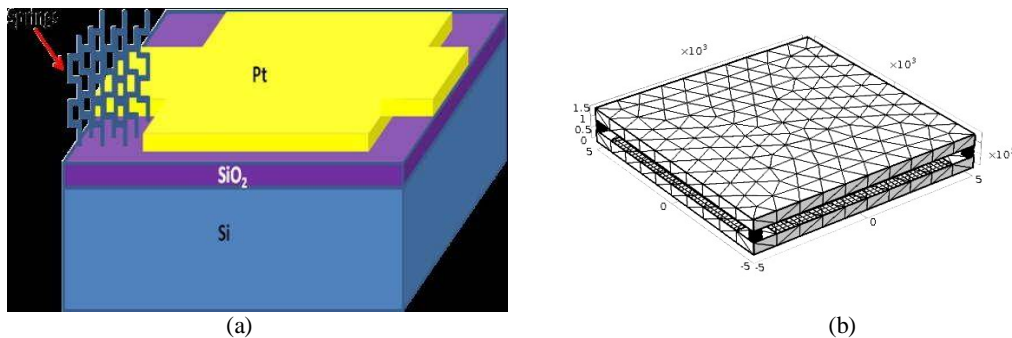

Fig. 6 (a) Electrode plate deposition of capacitive sensor with 9-spring attached (b) Meshed model of capacitive pressure sensor with 9-springs

International Journal of Innovative Research in Science, Engineering and Technology

(An ISO 3297: 2007 Certified Organization)

Website: www.ijirset.com

Vol. 6, Issue 5, May 2017

V. SIMULATION RESULTS AND DISCUSSIONPARAMETERS

Fig. 7, 8 & 9 shows the displacement and capacitance simulation results for capacitive pressure sensor with 1-spring, 4-springs and 9-springs using COMSOL MULTIPHYSICS MEMS CAD tool. The simulation analysis of all three models is done by applying uniform external pressure which ranges between 1Pa to 10,000Pa on the flexible diaphragm.

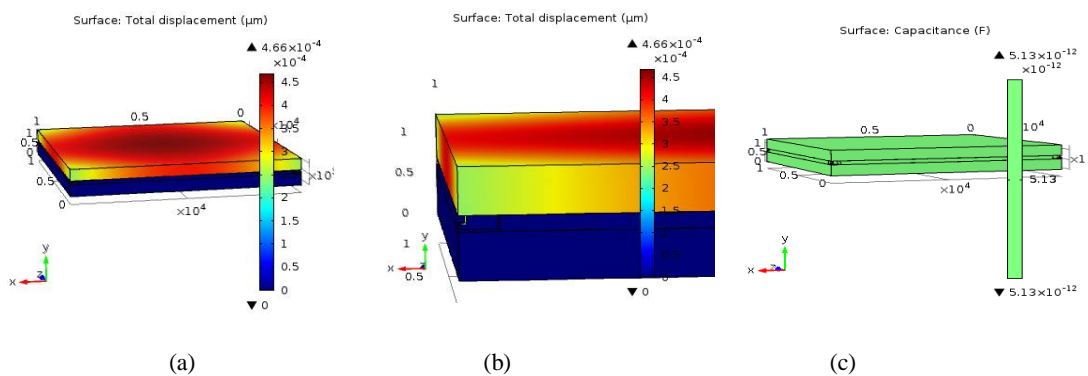

Fig. 7 (a) Diaphragm displacement of capacitive pressure sensor with 1-spring at 1Pa pressure applied (b) close view of spring displaced (c) Capacitance obtained at bias voltage of 1v.

The maximum deflection occurs at the centre of the diaphragm. Fig. 7 shows; at applied external pressure of 1pa the total displacement of 4.66×10^{-4} and capacitance of 5.13×10^{-12} is obtained for capacitive pressure sensor with 1-spring attached.

Table 2: shows the variation of displacement, capacitance and sensitivity with applied pressure for 1-spring model.

Pressure [Pa]	Displacement[um]	Capacitance[F]	Sensitivity (F/Pa)
1	4.66×10^{-4}	5.13×10^{-12}	5.13×10^{-12}
100	2.33×10^{-3}	5.14×10^{-12}	5.14×10^{-14}
500	0.12	5.14×10^{-12}	1.028×10^{-14}
1000	0.23	5.15×10^{-12}	5.15×10^{-15}
5000	1.17	5.17×10^{-12}	1.034×10^{-15}
10000	2.33	5.19×10^{-12}	5.19×10^{-16}

The table 2 lists the obtained displacement and capacitance values at different applied pressures for capacitive pressure sensor with 1-spring. It can be noted that as the applied pressure increases; the displacement of the diaphragm increases.

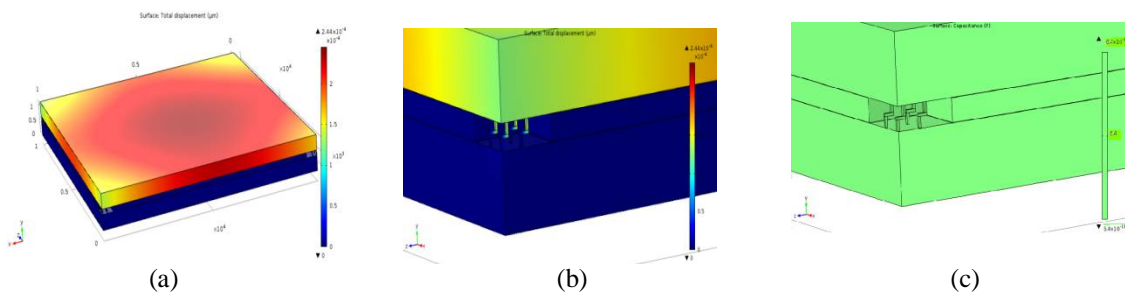

Fig. 8 (a) Diaphragm displacement of capacitive pressure sensor with 4-springs at 1Pa pressure applied (b) close view of springs displaced (c) Capacitance obtained at bias voltage of 1v.

International Journal of Innovative Research in Science, Engineering and Technology

(An ISO 3297: 2007 Certified Organization)

Website: www.ijirset.com

Vol. 6, Issue 5, May 2017

Fig. 8 shows; at applied pressure of 1pa the total displacement of $2.44e-4\mu\text{m}$ and capacitance of $6.4e-13\text{F}$ is obtained for capacitive sensor with 4-springs attached.

Table 3: shows the variation of displacement, capacitance and sensitivity with applied pressure for 4-spring model.

Pressure [Pa]	Displacement[μm]	Capacitance[F]	Sensitivity (F/Pa)
1	$2.44e-4$	$6.4e-13$	$6.4e-13$
100	$0.02e-2$	$6.14e-13$	$6.14e-15$
500	0.12	$6.37e-13$	$1.274e-15$
1000	0.24	$6.38e-13$	$6.38e-16$
5000	1.22	$7.87e-13$	$1.574e-16$
10000	2.44	$1.75e-12$	$1.75e-16$

The table 3 lists the obtained displacement and capacitance values at different applied pressures. It can be noted that as the applied pressure increases; the displacement of the diaphragm varies.

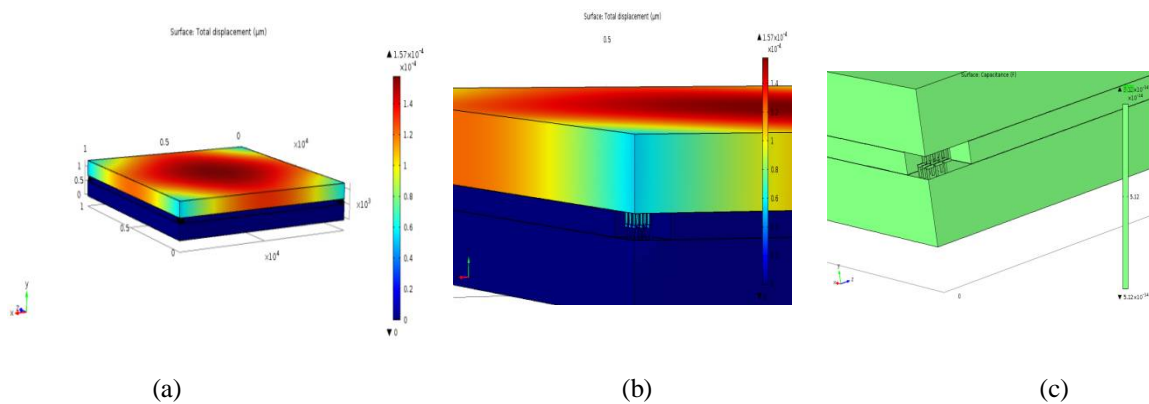

Fig. 9 (a) Diaphragm displacement of capacitive pressure sensor with 9-springs at 1Pa pressure applied (b) close view of springs displaced (c) Capacitance obtained at bias voltage of 1v.

Fig. 9 shows at applied external pressure of 1pa, the displacement of $1.57e-4\mu\text{m}$ and capacitance of $5.12e-14\text{F}$ is observed for capacitive pressure sensor with 9-springs.

Table 4: Shows the variation of displacement, capacitance and sensitivity with applied pressure for 9-spring model.

Pressure [Pa]	Displacement[μm]	Capacitance[F]	Sensitivity (F/Pa)
1	$1.57e-4$	$5.12e-14$	$5.12e-14$
100	$0.02e-2$	$5.13e-14$	$5.13e-16$
500	0.08	$5.15e-14$	$1.03e-16$
1000	0.16	$5.23e-14$	$5.23e-17$
5000	0.79	$5.27e-14$	$1.054e-17$
10000	1.57	$5.28e-14$	$5.28e-18$

International Journal of Innovative Research in Science, Engineering and Technology

(An ISO 3297: 2007 Certified Organization)

Website: www.ijirset.com

Vol. 6, Issue 5, May 2017

The table 4 lists the obtained displacement and capacitance values at different applied pressures for capacitive pressure sensor with 9-springs attached. It can be noted that as the applied pressure increases; the displacement of the diaphragm varies. By observing the above obtained results it is noted that the sensitivity of the capacitive pressure sensor with 9-springs is increased by comparing with capacitive pressure sensor with 1-spring and 4-springs. Further, these obtained values of displacement and capacitance of 9-spring capacitive sensor, the graph is plotted with pressure vs. displacement and pressure vs. capacitance which are shown in Fig. 10 and 11 respectively.

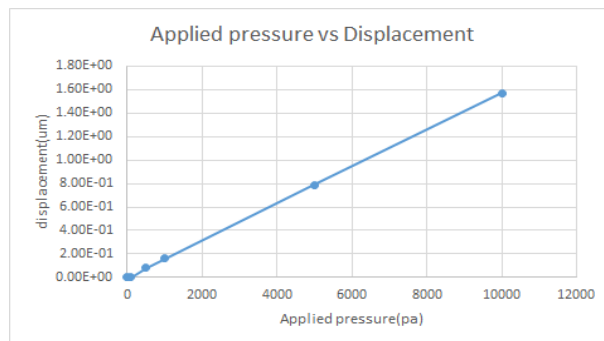

Fig. 10 Graph of applied pressure versus total displacement of capacitive pressure sensor with 9-springs.

Fig.10 shows the graph for applied pressure versus total displacement obtained during simulation of 9-spring model. By plotting the values obtained for displacement as the applied pressure increases, it can be noted that the displacement linearly increases along with the applied pressure.

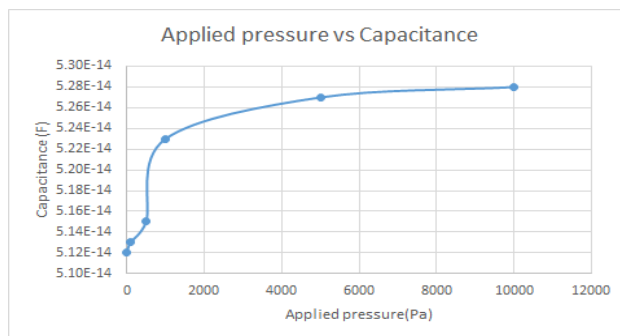

Fig. 11 Graph of applied pressure versus total Capacitance of capacitive pressure sensor with 9-springs.

Figure 11 shows the graph for applied pressure versus capacitance obtained for 9-spring model. By plotting the capacitance values obtained, it can be noted that capacitance increases as the applied pressure increases. At 10000pa of applied pressure, the capacitance of the capacitive pressure sensor with 9-springs is constant.

VI. CONCLUSION

In this paper MEMS based capacitive pressure sensor is designed, simulated and analysed for 1-spring, 4-spring and 9-spring capacitive pressure sensor using COMSOL MULTIPHYSICS. By above simulation results and discussions we noticed that the 9-spring capacitive pressure sensor model achieves a good sensitivity of 5.12e-14F/pa with displacement of 1.57e-4μm at applied pressure of 1pa as compared to 1-spring and 4-spring capacitive pressure sensors. Hence 9-spring capacitive sensors are much preferred for high sensitivity applications. The sensitivity of the sensor device can be improved by decreasing the thickness of the diaphragm structure and one can also look at the feasibility

International Journal of Innovative Research in Science, Engineering and Technology

(An ISO 3297: 2007 Certified Organization)

Website: www.ijirset.com

Vol. 6, Issue 5, May 2017

of fabricating the device. The capacitance sensitivity of the design increases as the number of springs increases. Hence the proposed capacitive pressure sensors can be used in health monitoring applications in the field of artificial intelligence systems and in wearable health care devices like blood pressure sensors, Electro cardiogram sensor etc.in which the sensor can achieve very high sensitivity.

ACKNOWLEDGEMENT

The authors would like to thank the Centre for Nanomaterial's and MEMS, Nitte Meenakshi Institute of Technology, Bangalore for providing the facilities to conduct this work.

REFERENCES

- [1] Hui-Yang Yu, Ming Qin, Jain-qiu Huang, and Qing-An Huang, "AMEMS Capacitive Pressure Sensor Compatible with CMOS Process" IEEE 2012.
- [2] Jachyuk Choi & Bumkyoo Choi, "Verification of the capacitive pressure sensor with additional air chambered", IEEE Biomedical Engineering International Conference (BMEiCON), 2015
- [3] Akhil K. Ramesh and Ramesh P., "Trade-off between sensitivity and Dynamic Range in designing MEMS Capacitive Pressure Sensor" IEEE 2015.
- [4] B. A. Ganji, M. Shams Nateri, "Modeling of capacitance and Sensitivity of a MEMS pressure sensor with clamped square Diaphragm", International journal of Engineering, Vol.26, No. 11, 2013
- [5] M. Srinagesh, Ch. Umasankar and K.Durga Aparna, "Design, Simulation and Analysis of MEMS Parallel Plate Capacitors for Pressure Measurement", International Journal of Engineering Research and Development, Volume 5, Issue 12, pp. 35-41, 2013.
- [6] Kirankumar B Balavalad, Bhagyashree Mudhol, B G Sheeparamatti, and Praveenkumar B. Balavalad, "Comparative Analysis on Design and Simulation of Perforated Mems Capacitive Pressure Sensor", International Journal of Engineering Research & Technology (IJERT), Vol. 4 Issue 07, 2015.
- [7] Y. Hezarjaribi, M.N. Hamidon, A. R. Bahadorimehr, S.H. Keshmiri, "Capacitive pressure sensor technology and applications", ICSE proceedings, 2008.