

An Approach for Multifocal Digital Image Fusion Using Wavelet Transformation and It's Quality Assessment

Kashmira S. Gulhane¹, Dr. P. L. Ramteke²

P.G. Student, Department of Information Technology, HVPM Engineering College, Anand Nagar, Maharashtra, India¹

Professor, Department of Information Technology, HVPM Engineering College, Anand Nagar, Maharashtra, India²

ABSTRACT: In today's era image fusion have the great emphasis on many fields such civilian sectors and defense areas to retrieve exact information about the particular image. Image Fusion is the process in which multiple images of the same scene are taken as input images and integrated in order to retrieve the best fused image which is more informative and complete than any of the input image. Image fusion aims at improving spectral information in a fused image as well as adding spatial details to it. Image fusion is the process of combining relevant information from two or more images into single images. Multisensor data fusion has become a discipline which demands more general formal solutions to a number of application cases. Several situations in image processing require both high spatial and high spectral information in a single image. In this paper, we have proposed a new approach of multimodal image fusion on wavelet transform coefficients. The performance of proposed image fusion method is evaluated with mutual information between input and output images.

KEYWORDS : Image Fusion, Multi-sensor, Wavelet transform, Spatial domain-based method, Transformed Domain-based method.

I. INTRODUCTION

Image fusion is the process of detecting salient features in the source images and fusing these details to a synthetic image. Through image fusion, extended or enhanced information content can be obtained in the composite image, which has many application fields, such as digital imaging, medical imaging, remote sensing, and machine vision. As an example, optical imaging camera suffers from the problem of finite depth of field, which cannot make objects at various distances (from the sensor) all in focus. Therefore, if one object in the scene is in focus, then the other objects at different distances from the camera will be out focus and blurred. The solution is to get all the objects focused in one image is multifocal image fusion technique. In this technique, several images of a scene are captured with focus on different parts. Basically, these methods can be categorized into two categories. The first category is the spatial domain-based methods, which directly fuse the source images into the intensity values. The other category is the transformed domain-based methods, which fuse image with certain frequency or time-frequency transforms. Image fusion has become an important sub area of image processing. For one object or scene, multiple images can be taken from one or multiple sensors. These images usually contain complementary information.

Image fusion has most common word used in medical diagnostics as well as treatment. Image fusion means it is combination of two input images of same scene to form a single image. The process of combining together relevant information or some of their features into a single image is termed as image fusion. The significance is to merge complementary information from two or more images of the same scene or part, so as to obtain an image which is more suitable for human visualization and machine perception. A single mode of image cannot give accurate and comprehensive information and hence the main focus is the image fusion. Image fusion is the technology that can take advantage of complementary information and redundancy information from different image sensors at the same time or at different times for the same scene by using some certain fusion rules and then the fused images are more accurate and more complete than the single image and more suitable for human visual perception and processing.

International Journal of Innovative Research in Science, Engineering and Technology

(An ISO 3297: 2007 Certified Organization)

Website: www.ijirset.com

Vol. 6, Issue 5, May 2017

II. LITERATURE REVIEW

Many works were made in the field of multi focal data fusion among the published works, the followings were chosen as selective material, because of their closeness to the area of our research work:

2.1 Related Research Work

Zhu Shu [1] presented a extracting more information from multi source image is an attractive thing is remotely sense image processing, which is recently called the image fusion. The image fusion algorithm based on wavelet transform is proposed to improve the geometric resolution of the image in which two images, which is processed are firstly decomposed into sub images with different frequency and then the information fusion is performed using these images under the certain criterion, and finally these sub images are reconstructed into the result image with plentiful information.

Prof. Eduardo Antonio Barros da Silva, Ph.D., Prof. Carla Liberal Pagliari, Ph.D., Prof. Hae Yong Kim, D.Sc., Prof. Claudio Rosito Jung, D.Sc. and Prof. Sergio Lima Netto, Ph.D. [2] presented a over the past two decades, image fusion has emerged as a new and exciting field of research within the image processing community. Generally speaking, image fusion refers to the process of integrating complementary and redundant information from multiple images into one composite image. Aim at providing new and improved image fusion algorithms by means of multiscale transforms. Based on the performance analysis of a variety of multiscale transforms, two novel fusion methods are proposed. Whereas the first fusion system operates slowly on the pixel-level, the second one employs region-level information to guide the fusion of infrared-visible image pairs

Kanagasabapathy and Vasuki [3] presented a new image fusion scheme based on wavelet transform has been proposed. The two input images are decomposed by applying Discrete Wavelet Transform upto the maximum level of decomposition possible. By decomposing the images, one approximation and three high frequency components of input image are obtained. The maximum coefficient rule is applied on the decomposed images to obtain the low and high frequency coefficients of the fused image. The fused image is obtained by applying Inverse Discrete Wavelet Transform. The performance measures for evaluating the fused image are entropy, correlation coefficient, mean and RMS value. The characteristics of the fused image are analyzed by the proposed method. As there is information redundancy and complementary among multiple images of the same scene obtained by different image sensors, it is particularly important to synthesize a new image by image fusion technology, which can provide more abundant information than original image.

III. PROPOSED WORK

The block diagram of proposed system is given in Figure:

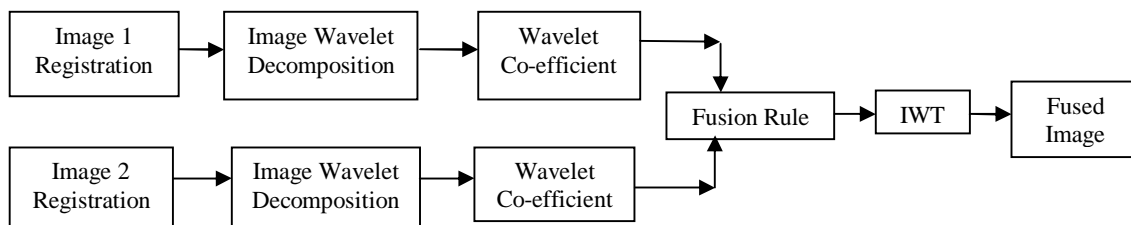

Figure 1: Block diagram of Image Fusion

3.1 Image Registration

Image registration is an image processing technique used to align multiple scenes into a single integrated image. It helps overcome issues such as image rotation, scaling, warping (nonlinear distortions), gray level transformations that are common when overlaying images. Image registration is often used in medical and satellite imagery to align images

International Journal of Innovative Research in Science, Engineering and Technology

(An ISO 3297: 2007 Certified Organization)

Website: www.ijirset.com

Vol. 6, Issue 5, May 2017

from different camera sources. Digital cameras use image registration to align and connect adjacent images into a single panoramic image. One of main issue in image fusion of different images is image alignment, which refers to pixel-by-pixel alignment of images. Image registration is the process of transforming different sets of data into one coordinate system. Data may be multiple photographs, data from different sensors etc. It is used in computer vision, medical imaging, military automatic target recognition and data from satellites. Image is nothing but matrix. For the resultant output image to be distinct and have a better visualization, both images should have same size. Same size of images also becomes a basic requirement for point to point correspondence between two pixel values. Image registration has applications in remote sensing and computer vision.

3.2 Image Wavelet Decomposition

Image wavelet decomposition means to decompose the image or Image divide, to separate the components of image. The decomposition involves low pass filtering and high pass filtering. As a mathematical tool, wavelets can be used to extract information from many different kinds of data, such as audio signals and images. A wavelet is a wave-like oscillation with amplitude that begins at zero i.e., increases and then decreases back to zero. Decomposition process is mathematically reversible because, wavelets will decompose data without gaps or overlap.

3.3 Wavelet Co-efficient

In Wavelet Co-efficient involved two methods such as Lifting wavelet transform and Stationary wavelet transform.

3.3.1 Lifting Wavelet Transform

The lifting scheme is a technique for both designing wavelet and performing the discrete wavelet transform. Actually it is worthwhile to merge these steps and design the wavelet filters while performing the wavelet transform. This is then called the second generation wavelet transform. Lifting wavelet transform just like a discrete wavelet transform. In numerical analysis and functional analysis, a discrete wavelet transform (DWT) is any wavelet transform for which the wavelets are discretely sampled. As with other wavelet transforms, a key Advantage it has over Fourier transforms is temporal resolution: it captures both frequency and location information (location in time).

- **Lifting Scheme Based Haar Wavelet Transform**

Two types of coefficients are obtained from the wavelet transform such as scaling coefficients and wavelet coefficients. Scaling coefficients are obtained by averaging two adjacent samples. Scaling coefficients requires adding two samples values and dividing by two. These scaling coefficients represent a coarse approximation of the speech. Wavelet coefficients are obtained from the subtraction two adjacent samples. Wavelet coefficients contain the fine details of the speech signal.

- **Haar Wavelets**

Haar wavelet is a sequence of rescaled "square-shaped" function. Haar wavelet is a wavelet family. Wavelet analysis is similar to Fourier analysis.

- **Predict Wavelet**

lifting scheme wavelets the predict wavelet transform starts with a split step, which divides the data set in to odd and even elements. The predict step uses a function that approximates the data set. The predict step, where the odd value is "predicted" from the even value is described by the equation:

$$\text{Odd}_{j+1,i} = \text{odd}_{j,i} - P(\text{even}_{j,i})$$

The "Down Sampling" in the predict wavelets does not provide an approximation of the data at each step, which is one of the requirements for filter design. The even elements that are used to "predict" the odd elements result for sampling the original data set by powers of two (example, 2,4,8....).

International Journal of Innovative Research in Science, Engineering and Technology

(An ISO 3297: 2007 Certified Organization)

Website: www.ijirset.com

Vol. 6, Issue 5, May 2017

- The Update Step**

The update step replaces the even elements. These results in a smoother input for the next step of the wavelet transform. The odd elements represent an approximation of the original data set, which allows for filter to be constructed. The above update phase follows the predict phase. The original value of the odd elements over written by the difference between the odd elements and its even “predictor”. So in calculating average the update phase must operate on the differences and that restored in the odd elements:

$$\text{Even}_{j+1,i} = \text{even}_{j,i} + U(\text{odd}_{j=1,i})$$

3.3.2 Stationary Wavelet Transform

Stationary Wavelet Transform also known as Undecimated wavelet transform. The Stationary wavelet transform (SWT) is a wavelet transform algorithm designed to overcome the lack of translation-invariance of the wavelet transform. The Wavelet Transform is a translation-variant transform. The way to restore the translation invariance is to use some slightly different WT, called Stationary Wavelet Transform (SWT). The SWT is an inherently redundant scheme as the output of each level of SWT contains the same number of samples as the input – so for a decomposition of N levels there is a redundancy of N in the wavelet coefficients. It does so by suppressing the down-sampling step of the decimated algorithm and instead up-sampling i.e., up-sampled are called “à torus”, meaning “with holes” the filters by inserting zeros between the filter coefficients, which mean that inserting zeros in the filters. SWT applications used for the Brain image classification and Pathological brain detections.

The Stationary wavelet transform (SWT) is a wavelet transform algorithm designed to overcome the lack of translation-invariance of the wavelet transform (WT). Translation-invariance is achieved by removing the down samplers and up samplers in the wavelet transform. The SWT is an inherently redundant scheme of output, at each level of SWT contains the same number of samples input. So for a decomposition of N levels there are a redundancy of N in the wavelet coefficients. The following block diagram show the digital implementation of SWT.

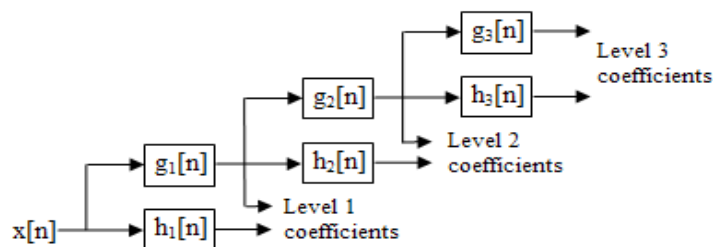

Figure 3: A Level 3 Co-efficient Using SWT Filter Bank

Above diagram show the filters in each level and up-sampled version (see the below figure)

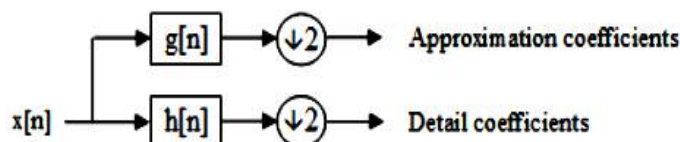

Figure 4: Stationary Wavelet Transform Filter

SWT contains Analysis-Decomposition Functions and Synthesis-Reconstruction Functions. Analysis function is used for the decomposition. Synthesis-reconstruction functions, is used for the reconstruction. SWT is also contained the 1-Dimensional wavelet Transform and 2-Dimensional wavelet Transform. 1-Dimensional wavelet Transform involved continuous wavelet Transform and 2-Dimensional wavelet Transform involved discrete continuous wavelet Transform. SWT is used for the Image Fusion.

International Journal of Innovative Research in Science, Engineering and Technology

(An ISO 3297: 2007 Certified Organization)

Website: www.ijirset.com

Vol. 6, Issue 5, May 2017

3.4 Fusion Rule

The wavelet transform coefficients obtained from the input images need to be combined to form a new set of coefficients to be used for backward transform. There are various fusion rules to form the fused wavelet coefficients matrix using the coefficients of the input images. Suppose A is visual image, B is infrared image, and F is considered as a Fusion. Fusion rule involved the High frequency sub band and the other is that low frequency sub band. The main purposed of the image fusion is that improved the input image quality. High frequency sub band involved LH, HL, and HH which is used for the maximum frequency and also is the sub images is extracted. Low frequency sub band which is important for quality of original image reconstructed.

3.5 Inverse Wavelet Transform (IWT)

Single level inverse Wavelet Transform show in figure:

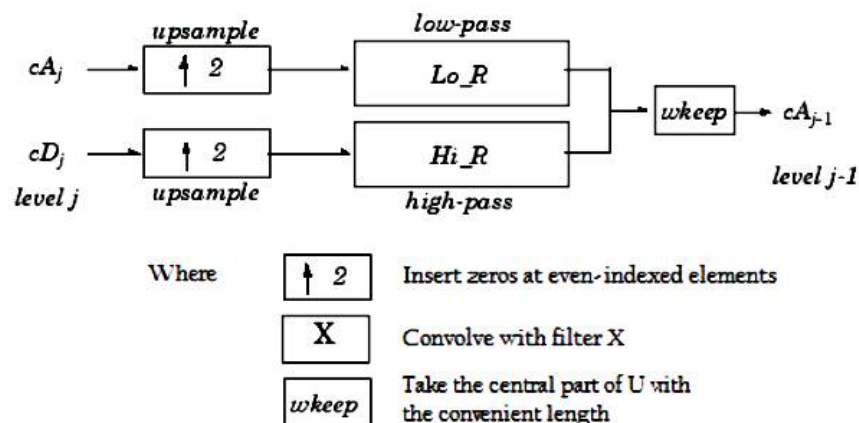

Figure 5: Dimensional Inverses Wavelet Transform

Inverse wavelet transform is used for the reconstruct the image. Coefficients at level j, cA_j and cD_j , the inverse wavelet transform reconstructs cA_{j-1} , inverting the decomposition step by inserting the zeros and convolving the results with the reconstruction filters.

- **Low Frequency Band Component**

Low band frequency components can be further decomposed until the desired resolution is reached or the low band frequency is the original image at coarser resolution level, it can be considered as a smoothed and sub sampled version of the original image.

- **High Frequency Band Component**

High frequency bands, the purpose of image fusion requires that the fused image must not discard any useful information contained in the source images and effectively preserve the details of input images.

3.6 Fused Image

At the final step get the aligned image that is registered image and having the fused coefficient of both the input images. When transforming points from one image to other different selection criteria is being to estimate a resulting fused image quality of images improves.

IV. RESULT AND DISCUSSION

We performed the experiment on different source image from different type of sensor and the proposed method is compared with Stationary wavelet transform and Lifting wavelet transform

International Journal of Innovative Research in Science, Engineering and Technology

(An ISO 3297: 2007 Certified Organization)

Website: www.ijirset.com

Vol. 6, Issue 5, May 2017



Figure 6 : Source images for multi-focus fusion (a) and (b), Fusion result (c)

- Result Analysis based on Stationary wavelet Transform

| Image Name | Stationary Wavelet Transform | | | | | | |
|------------|------------------------------|-------------------|--------|---------|-------------|---------|---------|
| | Total Execution Time | Mean Square Error | RMSE | PSNR | Correlation | SNR | Entropy |
| Image 1 | 1.9966 seconds | 17.9896 | 2.0595 | 35.5806 | 0.9767 | 11.8812 | 4.7309 |
| Image 2 | 0.5983 seconds | 14.6508 | 1.4685 | 41.4555 | 0.9976 | 17.0811 | 7.0764 |
| Image 3 | 0.5930 seconds | 14.4773 | 1.9679 | 36.3519 | 0.9966 | 16.1013 | 6.9333 |
| Image 4 | 0.6039 seconds | 40.0994 | 2.5164 | 32.0994 | 0.9724 | 11.1783 | 7.5473 |
| Image 5 | 0.5779 Seconds | 19.0831 | 2.0901 | 35.3243 | 0.9809 | 18.9317 | 6.6910 |

Table 1: Evaluation of Result Based on Stationary Wavelet Transform

- Result Analysis based on Lifting wavelet Transform

| Image Name | Lifting Wavelet Transform | | | | | | |
|------------|---------------------------|-------------------|--------|---------|-------------|---------|---------|
| | Total Execution Time | Mean Square Error | RMSE | PSNR | Correlation | SNR | Entropy |
| Image 1 | 0.1770 seconds | 18.7901 | 2.0820 | 35.3915 | 0.9683 | 11.9482 | 4.7351 |
| Image 2 | 0.2190 seconds | 18.8359 | 1.7241 | 38.6683 | 0.9940 | 13.7240 | 7.0927 |
| Image 3 | 0.2208 seconds | 21.0071 | 2.1409 | 34.9071 | 0.9825 | 9.7856 | 7.3311 |
| Image 4 | 0.2191 seconds | 54.3347 | 2.7150 | 30.7800 | 0.9486 | 9.8417 | 7.5816 |
| Image 5 | 0.2001 Seconds | 24.5458 | 2.2258 | 34.2310 | 0.9588 | 6.9846 | 6.7380 |

Table 2: Evaluation of Result Based on Lifting Wavelet Transform

International Journal of Innovative Research in Science, Engineering and Technology

(An ISO 3297: 2007 Certified Organization)

Website: www.ijirset.com

Vol. 6, Issue 5, May 2017

V. CONCLUSION

Image fusion method which is based on the wavelet transform, which include the parameters like Mean Square Error, peak signal to noise ratio (PSNR), Total Execution Time, root mean square error (RMSE), SNR, Correlation, and Entropy. These are evaluated to prove our method will be efficient with respect to others proposed method. As shown in above result for image, the value of MSE by Lifting wavelet transform is more as compare to the value of MSE and the stationary wavelet transform is MSE value is less. The value of PSNR by lifting wavelet transform is more as compare to the value of PSNR by stationary wavelet transform is less. Also RMSE by stationary wavelet transform is less as compare to RSME by lifting wavelet transform is more. The value of entropy by stationary wavelet and the value of entropy by Lifting wavelet transform are near about same. So from above discussion, stationary wavelet transform is best for tested images.

REFERENCES

- [1] Hamid Raza, Shaha doosti and Hassan Ghassemmina, "Fusion of MS and PAN Images Preserving Spectral Quality", IEEE Transactions on Geosciences and Remote Sensing Letters, vol: 12, issue: 3, pp: 611-615, March 2015.
- [2] Reshma James.; M. Vadivel, "Improvement of Spectral and Spatial Information using Modified WAMM and Modified Bi- Cubic Interpolation Method in Non-Sub sampled Contour let Transform domain", IEEE International Conference on Circuit, Power and Computing Technologies, pp: 1-5, 2015.
- [3] J. Marcello, A. Medina, and F. Eugenio, "Evaluation of Spatial and Spectral Effectiveness of Pixel Level Fusion Techniques", IEEE Geosci. Remote Sens. Lett. vol. 10, no. 3, pp. 432-436, May 2013.
- [4] Deepak Kumar Sahu and M. P. Parsai, "Different Image Fusion Techniques- A Critical Review", Vol. 2, Issue. 5, pp-4298-4301, Sep.-Oct. 2012.
- [5] Y. Kim, C. Lee, D. Han, Y. Kim, and Y. Kim, "Improved Additive-Wavelet Image Fusion", IEEE Geosci. Remote Sens. Lett., vol. 8, no. 2, pp. 263-267, Mar. 2011.
- [6] Bin Yang and Shutao Li, Member IEEE, "Multi focus Image Fusion and Restoration with Sparse Representation", VOL. 59, NO. 4, pp 884 -892, April 2010.
- [7] ShuQin Ren1, Jian Cheng1, Min Li2, "Multi-resolution Fusion of Pan and Ms Images Based on the Curve let Transform", IEEE, 2010.
- [8] S. Ibrahim and M. Wirth, "Multi Resolution Region-Based Image Fusion Using the Contour Let Transform", in IEEE TIC-STH, Sept. 2009.
- [9] Z. Liu, D. S. Forsyth, M.-S. Safizadeh, and A. Fahr, "Adata-fusion scheme for quantitative image analysis by using locally weighted regression and Dempster Shafer theory", IEEE Trans. Instrum. Meas., vol. 57, no. 11, pp. 2554-2560, Nov. 2008.
- [10] Juliana G. Denipote and Maria Stela V. Paiva, "A Fourier Transform-based Approach to Fusion High Spatial Resolution Remote Sensing Images", IEEE Sixth Indian Conference on Computer Vision, Graphics & Image Processing, and pp: 179-186, 2008.
- [11] S. Zheng, W. Z. Shi, J. Liu, G. X. Zhu, and J. W. Tian, "Multisource Image Fusion Method Using Support Value Transform", IEEE Trans. Image Process., vol. 16, no. 7, pp. 1831-1838, Jul. 2007.
- [12] Z. Wang, D. Ziou, C. Armenakis, D. Li, and Q. Li, "A Comparative Analysis of Image Fusion Methods", IEEE Trans. Geosci. Remote Sens., vol. 43, no. 6, pp. 1391-1402, Jun. 2005.