

Optimization of Renewable Energy Sources Connected in Microgrid using Different Control Strategies

Ujwala S. Raut¹, Y. D. Shahakar²

M. E Student, Department of Electrical Engineering, P. R. Pote (Patil) College of Engineering and Management,
Amravati, India

Assistant Professor, Department of Electrical Engineering, P. R. Pote (Patil) College of Engineering and Management,
Amravati, India

ABSTRACT: The proposed operational strategy is mainly focused on using an appropriate energy management and control strategies to optimize the operation of a dc microgrid, formed by Wind and photovoltaic (PV) solar energy, batteries, and loads. Operational controls are designed to support the integration of wind and solar power within microgrids. The proposed power/frequency characteristics, of the hybrid unit and of the whole microgrid, adapt autonomously to the microgrid operating conditions so that the hybrid unit may supply the maximum PV power, match the load, and/or charge the battery, while maintaining the power balance in the microgrid and respecting the battery state-of-charge limits.

KEYWORDS: Microgrid, Maximum Power point Tracking (MPPT), Photo-voltaic (PV), Wind, Incremental conductance (IC)

I. INTRODUCTION

An optimization is the design and operation of a system or process to make it as good as possible in some defined sense. In Indonesia, the usage of fossil energy including coal, gas and oil are believed as the primary energy source of the power plant. According to the demand of electric power in industrial and commercial development, need of photovoltaic energy and related technology is important to implement. At present, scale of renewable energy and large scale photovoltaic power generation has become parts of development strategy, until something expected to happen, it is the way to guide the development of photovoltaic industry. As its own characteristics different from conventional power generation. Grid-connected PV power station and its stability, security, and reliable operation became new challenges which power grid and PV power plant need to face. So results can be optimize by using recent technology like PWM, MPPT and control strategies.

India electricity exports surpassed its imports for the first time ever in the country's history since independence. According to the Central Electricity Authority, a Government of India authority dealing in cross border electricity trade, India exported around 5,798 million units to Nepal, Bangladesh and Myanmar in 2016-17 period. At the same time, India imported around 5,585 million units from Bhutan, which is 213 million units less than exports. The utility electricity sector in India has a National Grid with an installed capacity of 319.60 GW (as of 31 March 2017.) Renewable power plants constituted 30.3% of total installed capacity. During the fiscal year 2015-16, the gross electricity generated by utilities in India was 1,116.84 TWh and the total electricity generation (utilities and non-utilities) in the country was 1,352 TWh or 1,075.64 kWh per capita. India is the world's third largest producer and fourth largest consumer of electricity. Electric energy consumption in agriculture was recorded highest (17.89%) in 2015-16 among all countries. The per capita electricity consumption is low compared to many countries despite cheaper electricity tariff in India.

International Journal of Innovative Research in Science, Engineering and Technology

(An ISO 3297: 2007 Certified Organization)

Website: www.ijirset.com

Vol. 6, Issue 5, May 2017

II. LITERATURE REVIEW

[1] In this project, in consistence with the previous design of the perturbation parameters the MPPT controller incorporating an RPM algorithm was developed. That control algorithms was based on a VSIC method. Support to increase renewable energy sources an aggregated model of renewable wind and solar power generation proposed. And equilibrium of the micro grid's real-time supply and demand, implemented high-rise host building of an urban area

[2] In this project, author presented the state-of-the-art on stochastic modelling and optimization tools for microgrid planning, operation, and control. To locate the randomness in renewable power generation, the buffering effect of energy storage devices and the mobility of PEVs in V2G systems the tools can be used. Furthermore, the unique features of micro-grid are the dual (islanded and grid-connected) operation modes, the spatial correlation of renewable power generation and integration of CHP with both electricity and heat outputs, were taken into account.

[4] In this the author said that, proportion of electricity produced from renewable energy sources records tremendous growth. It happened in accordance with strategies, which aimed to decrease the production of carbon emissions and greenhouse gases. But, on other side it results in so many changes and related problems in electric power system especially with its optimal operation control. It can be solved by growth of electricity, which can provide better implementation of renewable energy sources due to its power supply and it also helps to prepare conventional distribution grids to new smart grid concept.

[8] The integration of wind, solar power and flying capacitor with DC micro grids. An aggregated model of renewable wind and solar power generation proposed to support the increases renewable energy sources and equilibrium of the micro grid's real-time supply and demand, implemented high-rise host building of an urban area. The MPPT controller incorporating an RPM algorithm was developed in consistence with the previous design of the perturbation parameters.

III. PROPOSED WORK

A. Microgrid

Microgrid is a localized grouping of electricity generation, energy storage, and load that may operate in stand-alone or grid connected mode. The proposed microgrid system designed with two renewable energy sources such as wind and solar power systems which are interfaced to the DC bus with the help of the power electronic components such as DC to DC converter, AC to DC converter and DC to AC converter. To control electrical loads the micro grid generates one output from the different available input power sources. Direct supply to the DC loads is possible using the power generated from a solar electric system and wind power generating stations or we can store the DC power in batteries. Figure 1 shows the complete architecture of microgrid.

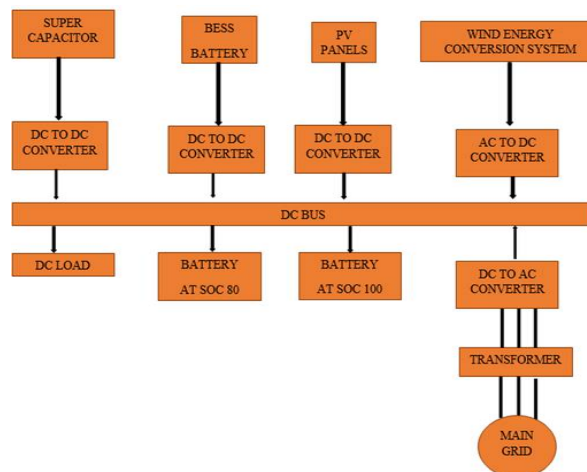

Fig.1 Layout of Microgrid

International Journal of Innovative Research in Science, Engineering and Technology

(An ISO 3297: 2007 Certified Organization)

Website: www.ijirset.com

Vol. 6, Issue 5, May 2017

B. Wind System

Figure 2 shows system level layout of a wind energy system. To ensure low maintenance costs and efficient performance wind turbine control is necessary. The control system also assures safe operation, optimizes power output, and ensures long structural life. The generator speed and turbine rotational speed are two key areas which are essential to control for power optimization and limitation. There are different control methods to optimize or to limit power output such as Blade angle adjustment, Turbine by controlling the generator speed and Rotation of the entire wind turbine.

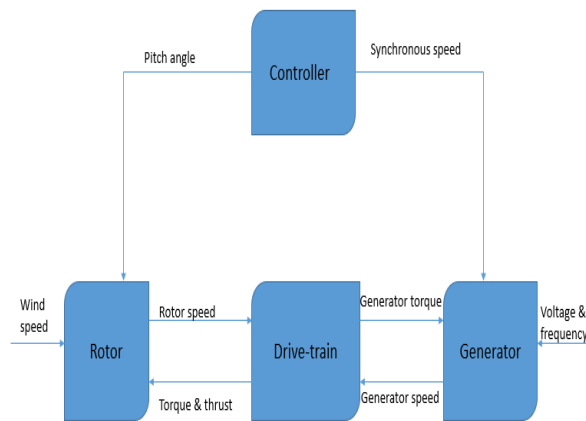

Fig.2 System Level Layout of a Wind Energy System

C. Solar System

Photovoltaic cell is one of the most popular renewable sources. A photovoltaic system has benefits such as being quite and static as it has no moving parts. At present, the total energy consumption in the world is fourteen terawatts (TW) at any given moment, and this consumption is estimated to be about two times higher by 2050. To match that demand, all forms of energy need to be increased rapidly in the coming years. The use of traditional energy resources such as fossils fuel is not admissible, due to its greenhouse gas emissions and pollution. Because of that there has been rapid development of renewable energy technologies to meet the future energy demand and to create a sustainable free pollution energy economy.

A dc current which depends on the intensity of solar irradiance and room temperature generated by PV module. The power produced by a PV module corresponds to a value measured in watt-peak. The standard test conditions allow the power capacity corresponding to a solar irradiance level of 1000 W/m and room temperature of 25°C. Typically, parameters such as the open circuit voltage, short circuit current and MPP ratings are measured under STC and provided in datasheets by manufacturers. The PV module is typically connected to a charge controller called as MPP tracker in order to optimize the extracted dc power, which varies with both irradiance and temperature levels. Some important MPPT techniques are Fixed Duty Cycle, Constant Voltage (CV), Perturb and Observe (P&O), Incremental Conductance (IC).

Modified Incremental conductance Method

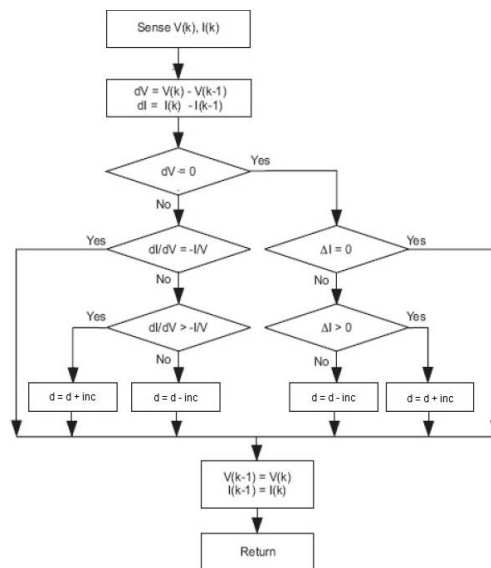

Fig.3 Flowchart representation of MPPT techniques: Modified Incremental conductance

In this proposed system a modified incremental conductance with direct control is selected. The flowchart of this direct control method is shown in figure 3. The algorithm starts its cycle by obtaining present and previous values of voltage and current. Main check is carried out by comparing (dI/dV) against $(-I/V)$. According to the result of this check duty cycle is adjusted in order to obtain maximum power from the solar PV module.

D. Battery Energy Storage System

An electric battery is apparatus consisting of one or more electrochemical cells with external connections provided to power electrical devices such as electric cars, flashlights, and smart phone. When a battery is supplying electric power, its negative terminal is the anode and its positive terminal is the cathode. The terminal marked negative is the source of electrons that when connected to an external circuit will flow and deliver energy to an external device. When an external circuit is connected to a battery, electrolytes are able to move as ions within, allowing the chemical reactions to be completed at the separate terminals and so deliver energy to the external circuit. It is the movement of those ions within the battery which allows current to flow out of the battery to perform work.

E. Super Capacitor

Super-capacitors are also called as flywheel and are differ from an ordinary capacitor in two important ways: its plates effectively have a much bigger area and the distance between them is much smaller, because the separator between them works in a different way to a conventional dielectric. As like an ordinary capacitor, super capacitors also have two plates that are separated. The plates are made from metal coated with a porous substance such as powdery, activated charcoal, which effectively gives them a bigger area for storing much more charge e.g. Consider electricity is water for a moment, where an ordinary capacitor is like a cloth that can mop up only a tiny little spill, a super capacitors porous plates make it more like a chunky sponge that can soak up many times more.

International Journal of Innovative Research in Science, Engineering and Technology

(An ISO 3297: 2007 Certified Organization)

Website: www.ijirset.com

Vol. 6, Issue 5, May 2017

IV. RESULT

MODELLING OF MICROGRID WITH RENEWABLE ENERGY SOURCES

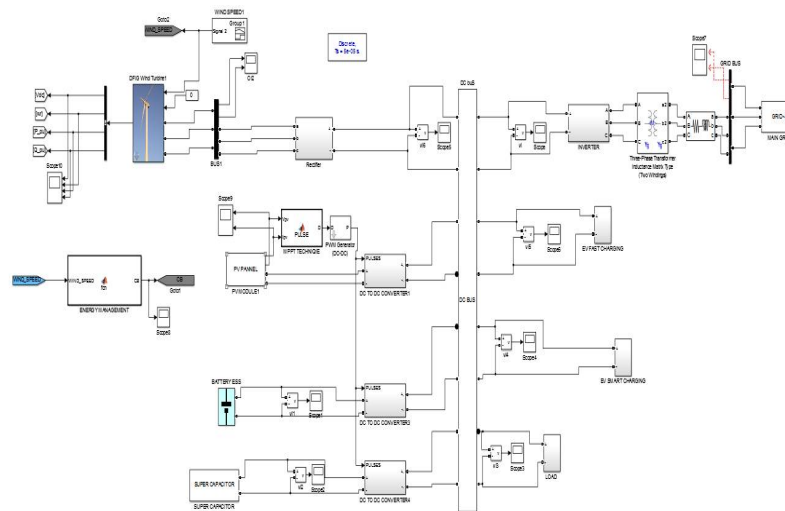

Fig. (a)

In this, the layout of microgrid is verified by using simulation. Microgrid for renewable power integration, the dc bus connects wind energy conversion system (WECS), PV panels, multilevel energy storage comprising battery energy storage system (BESS) and super capacitor, EV smart charging points, EV fast charging station, and grid interface. The wind power system, Photovoltaic system, Battery and Super capacitor are connected to DC bus by using power electronics components. Figure (a) shows layout of microgrid for renewable energy sources.

OUTPUT OF WIND POWER SYSTEM

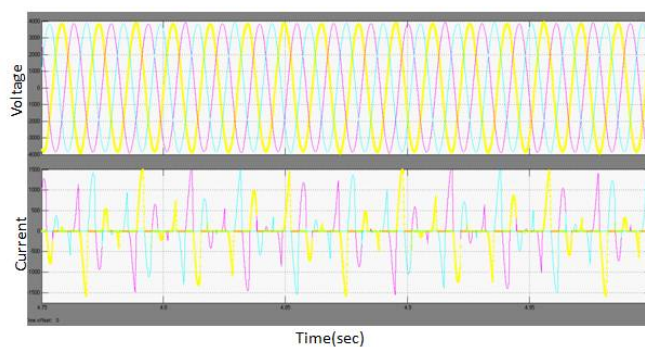

Fig. (b)

The wind speed in m/s is given as input and different control strategies are used for to optimize power and the voltage and current output waveform of wind energy conversion system are shown in figure (b).

International Journal of Innovative Research in Science, Engineering and Technology

(An ISO 3297: 2007 Certified Organization)

Website: www.ijirset.com

Vol. 6, Issue 5, May 2017

OUTPUT OF RECTIFIER

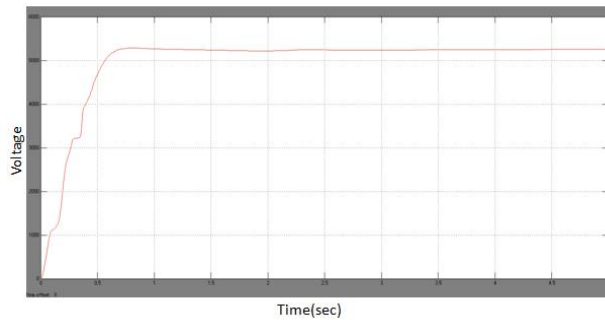

Fig. (c)

The output of wind energy conversion system is given to the rectifier to convert it into dc power so that it can be used to connect to DC bus. So the output of rectifier is shown in figure (c).

OUTPUT OF PV SYSTEM

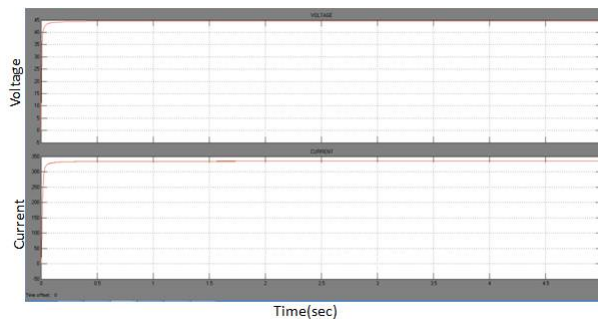

Fig. (d)

The standard rating of irradiance i.e. 1000 w/m² is considered as input. Here, Output waveform of photovoltaic system with Maximum power point tracker is shown in figure (d)

BATTERY OUTPUT

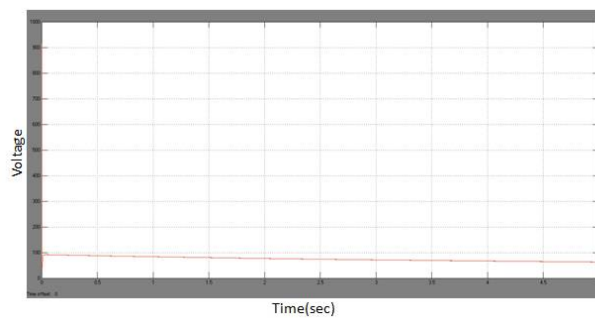

Fig. (e)

International Journal of Innovative Research in Science, Engineering and Technology

(An ISO 3297: 2007 Certified Organization)

Website: www.ijirset.com

Vol. 6, Issue 5, May 2017

This is the output waveform of Battery energy storage system (BESS) with maximum power point tracker used and it is shown in figure (e)

OUTPUT OF SUPER-CAPACITOR

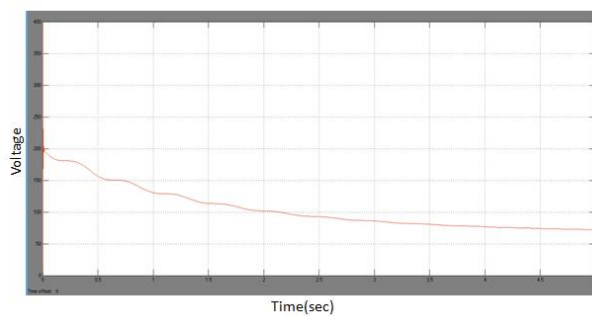

Fig. (f)

Figure (f) shows the output of Super capacitor. Super capacitor generally used for to control fast power fluctuations.

OUTPUT OF GRID

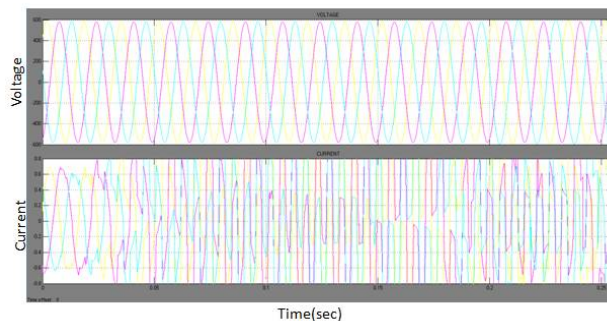

Fig. (g)

Figure (g) shows output waveform of voltage and current of grid. Here DC bus is connected to the AC grid by using inverter.

FAST CHARGING

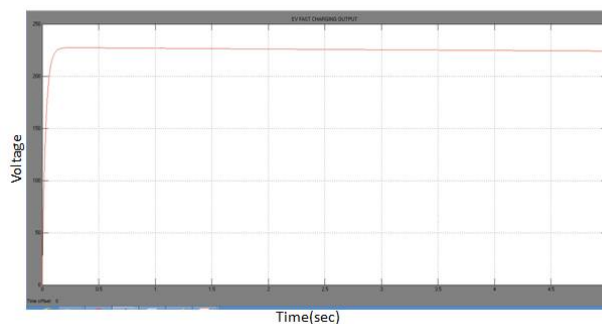

Fig. (h)

International Journal of Innovative Research in Science, Engineering and Technology

(An ISO 3297: 2007 Certified Organization)

Website: www.ijirset.com

Vol. 6, Issue 5, May 2017

Figure (h) shows output waveform of fast charging where SOC (State of charge) is 100%.

SMART CHARGING

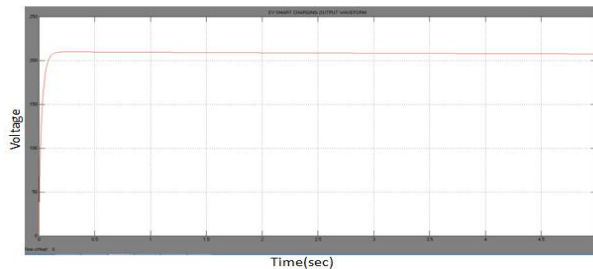

Fig. (i)

Figure (i) shows output waveform of fast charging where SOC (State of charge) is 80%.

PV OUTPUT WITHOUT MPPT

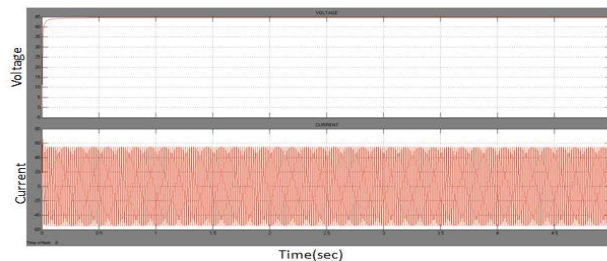

Fig. (j)

The standard rating of irradiance i.e.1000 w/m² is considered as input. Here, Output waveform of photovoltaic system without Maximum power point is shown in figure (j).

COMPARATIVE STUDY FOR WITH AND WITHOUT MPPT

Table1. Comparison of parameter between with and without MPPT system

Sr. no.	Parameters	With MPPT	Without MPPT
1.	Photo voltaic panel output	Better	Poor
2.	Life of Battery	More	Less
3.	Cost	Less	More
4.	Efficiency	High	Low
5.	Maintenance cost	Low	High
6.	Voltage boosting capability	High	Low
7.	Battery charging capacity	High	Low

International Journal of Innovative Research in Science, Engineering and Technology

(An ISO 3297: 2007 Certified Organization)

Website: www.ijirset.com

Vol. 6, Issue 5, May 2017

From the above comparison it is concluded that the grid connected renewable sources with MPPT is optimized than the grid connected renewable sources without MPPT because of various advantages.

V. CONCLUSION

In this implementation a micro grid-connected to hybrid PV–wind-battery- super capacitor based power evacuation scheme for various applications is proposed. The proposed hybrid system provides an elegant integration of PV and wind source to extract maximum energy from the two sources. A versatile control strategy which achieves a better utilization of PV, wind power, battery capacities without effecting life of battery and power flow management in a grid-connected hybrid PV–wind-battery-based system feeding ac loads is implemented. From the above study it is concluded that the modified method of MPPT gives optimize results as compared to Incremental conductance method. The well known PWM technique is used for inverter side to improve the output efficiency. It can be seen that oscillation can prevented and is able to quickly track the optimal operating point in severe transient conditions with changes of solar radiation and temperature by the proposed algorithm.

REFERENCES

1. Ch Uday Kiran, K. Mahesh "Integration of renewable energy sources wind and solar power grid connected using MPPT and flywheel /Simulink" Volume: 03 Issue: 10 | Oct -2016 in IRJET
2. "DC Microgrid for Wind and Solar Power Integration" IEEE JOURNAL OF EMERGING AND SELECTED TOPICS IN POWER ELECTRONICS, VOL. 2, NO. 1, MARCH 2014 115.
3. Hao Liang , Weihua Zhuang "Stochastic Modeling and Optimization in a Microgrid: A Survey" Energies 2014, 7, 2027- 2050; doi:10.3390/en7042027.
4. Martin Vojtek , Michal KOLCUN "Optimization the operation of renewable energy sources in electric power system" IEEE TRANSACTIONS ON INDUSTRIAL ELECTRONICS, VOL. 61, NO. 8, AUGUST 2014.
5. Md. Ruhul Amin Rajib Baran Roy and Md. Mahmudul Hasan "Modeling and Optimization of Decentralized Microgrid System for St. Martin's Island in Bangladesh" International Journal of Energy, Information and Communications Vol.5, Issue 5 (2014).
6. Manzar Ahmed, Uzma Amin, Suhail Aftab, Zaki Ahmed "Integration of Renewable Energy Resources in Microgrid", Energy and Power Engineering, 2015, 7, 12-29.
7. Duc Nguyen Huu, Hung Truong Nam, " DC Microgrid for Buildings Integrated Renewable Energy Sources" December 2016.
8. Chudaykiran, Mahesh, " Integration of Renewable Energy Sources Wind and Solar Power Grid Connected Using MMPT & Flywheel /Simulink.
9. A. G. Madureira and J. A. Pecas Lopes, "Coordinated voltage support indistribution networks with distributed generation and microgrids," IET Renew. Power Generat., vol. 3, no. 4, pp. 439– 454, Dec. 2009.
10. MMPT & Flywheel M. H. Nehrir, C. Wang, K. Strunz, H. Aki, R. Ramakumar, J. Bing, et al., "A review of hybrid renewable/alternative energy systems for electric power generation: Configurations, control, and applications," IEEE Trans. Sustain. Energy, vol. 2, no. 4, pp. 392–403, Oct. 2011.
11. Simulink day kira F. Giraud and Z. M. Salameh, "Steady-state performance of a grid connected rooftop hybrid wind-photovoltaic power system with battery storage," IEEE Trans. Energy Converts., vol. 16, no. 1, pp. 1–7, Mar. 2001.
12. T. B. Johansson et al. "Renewable fuels and electricity for a growing world economy: Defining and achieving the potential," in Renewable Energy: Sources for Fuels and Electricity, Washington, D.C.: Island Press, 1993, pp. 1-7
13. D. Holm, "Renewable energy future for the developing world," International Solar Energy Society, ISES Headquarters, Freiburg, Germany, White Paper, 2005.
14. Swathy. A. S, Archana .R "Maximum Power Point Tracking Using Modified Incremental Conductance for Solar Photovoltaic System" International Journal of Engineering and Innovative Technology (IJEIT) Volume 3, Issue 2, August 2013.
15. Dezso Sera, Laszlo Mathe, Tamas Kerekes, Sergiu Viorel Spataru, Remus Teodorescu "On the Perturb-and-Observe and Incremental Conductance MPPT Methods for PV Systems" IEEE Journal of Photo-voltaics, Volume: 3 Issue: 3