

## International Journal of Innovative Research in Science, Engineering and Technology

(An ISO 3297: 2007 Certified Organization)

Website: [www.ijirset.com](http://www.ijirset.com)

Vol. 6, Issue 5, May 2017

# Establishing Congestion Control in E-Government Mobile ADHOC Grid Services

P.Sathya<sup>1</sup>, Dr.M.Deepamalar<sup>2</sup>

M.Phil Scholar, Post Graduate and Research Department of Computer Science, Parvathy's Arts and Science College,  
Dindigul, India<sup>1</sup>

Asst Prof, Post Graduate and Research Department of Computer Science, Parvathy's Arts and Science College,  
Dindigul, India<sup>2</sup>

**ABSTRACT:** In the present days of global economic meltdown, the government of the developing countries like INDIA are facing server challenge in maintaining an efficient administration in its core and allied sector within an affordable budget. With increasing generalization of technology access by national and organization, e-governments across the globe face a services challenge to keep a pace with ever dynamical technologies and afferent economical, effective and clear manner of providing its services. Mobile ad hoc grid technology could be solution for resource sharing and interoperability of e-government systems. Mobile ad hoc grid for e-government deals with the challenges in resource discovery and job scheduling. In the paper a new mobile ad hoc computing technique for e-governance is implemented to manage the congestion control with job scheduling. The proposed addition of the mobile ad hoc network for e-governance with in AHGL can offer maximum network utility.

**KEYWORDS:** Congestion control, AHGL, Mobile Ad-hoc Network,

### I.INTRODUCTION

This paper explained how Government at different levels can apply Information and Communication Technology (ICT) to achieve efficiency, effectiveness, transparency and accountability in Government to Government (G2G), Government to Employee (G2E), Government to Citizen (G2C) and Government to Business (G2B). This application is referred to as Electronic Governance (e-Governance). The system enables citizens to make best use of automated administration processes that are accessible on-line. Grid computing is an ideal solution to this type of administrative processes. This paper therefore presents how Grid computing can be used to effectively and efficiently meet the yearnings of citizenry. In this paper demonstrated the creation of a virtual environment by using Grid technologies to a specific e-governance application on distributed resources. This presented a framework for the adoption of grid computing for e-governance management using Electronic Bill server (EB server), Comprehensive Welfare and Social Services server (CWSS server) and Corporation sever (C server). Experiments were run with the Grid environment and without Grid environment by considering the number of jobs completed and the period to complete various jobs. The Grid Computing Information Centre aims to promote the development and advancement of technologies that provide seamless and scalable access to wide-area distributed resources. Computational Grids enable the sharing, selection, and aggregation of a wide variety of geographically distributed computational resources (such as supercomputers, Compute cluster, Storage System, data sources, instruments, people) and presents them as a single, unified resource for solving large-scale compute and data intensive computing applications (e.g molecular modelling for drug design, brain activity analysis, and high energy physics. This idea is analogous to electric power network(grid) where power generators are distributed, but the users are able to access electric power without bothering about the source of energy and its location. In a congested network, response time slows with reduced network throughput. Congestion occurs when bandwidth is insufficient and network data traffic exceeds capacity. Data packet loss from congestion is partially countered by

# International Journal of Innovative Research in Science, Engineering and Technology

(An ISO 3297: 2007 Certified Organization)

Website: [www.ijirset.com](http://www.ijirset.com)

Vol. 6, Issue 5, May 2017

aggressive network protocol retransmission, which maintains a network congestion state after reducing the initial data load. This can create two stable states under the same data traffic load - one dealing with the initial load and the other maintaining reduced network throughput.

## II. RELATED WORK

This paper explained how government at different levels can apply information and communication technology to achieve efficiency, effectiveness, transparency and accountability in government to government(G2G), Government to Employee(G2E), Government To citizen(G2C), Government to Government(G2G). Is explained by D.G Iyanda et al.<sup>[1]</sup> In this paper, they demonstrated the creation of virtual environments by using grid technology to a specific e-governance application and distributed resource. This presented a framework for the adoption of grid social (CWSS server) and cooperation server(C server) experiments were run with the grid environment and without grid environment by considering the number of jobs completed and the period to complete various jobs submitted for processing using MATLAB. The result of simulation revolved that implementing an e-governance solution was caused effective, efficient, and consistent and reduce job processing time with high quality of result and providing better service to citizens. Sandeep Rana et al. proposed Join Scheduling and congestion Control in Mobile Ad-Hoc Networks this paper define a specific network utility maximization problem that they believe is appropriate for mobile adhoc networks. This paper describe a wireless Greedy Primal Dual(WGPD) algorithm for combine congestion Control Scheduling that aims to solve this problem. This paper show all how the WGPD algorithm and its associated signaling can be implemented in practice with minimal disruption to existing wireless protocols. M. Dickens<sup>[2]</sup> et al. proposed Application-Level Congestion Control Mechanisms for Large Scale Data Transfers Across Computational Grids In this paper, discuss the development of a highly efficient, application-level data transfer system for computational grids. These describe and evaluate two application-level congestion control mechanisms, and compare their performance with respect to each other and with that obtained by TCP. This show that both application-level protocols are able to obtain performance that is very close to the maximum available bandwidth while keeping data loss rates low (from 0.06% to 1.6 %). Also, This show that both approaches obtain throughput that is close to an order of magnitude greater than that achieved by TCP. R. Bhaskaran<sup>[3]</sup> et al. proposed Performance Analysis of Congestion Control In Mobile Adhoc Grid Layer Mobile Ad Hoc Grid deals with the challenges in resource discovery and job scheduling due to its mobility and power consumption. In this paper a new grid computing technique is implemented to manage the congestion control with job scheduling. The proposed addition of the mobile ad hoc network within AHGL can offer maximum network utility. The model is implemented in the NS-2 network simulator.

## III. ROLE OF GRID IN E- GOVERNMENT

Grid computing architecture is a collaborative, network-based model that enables the sharing of computing resources: data, applications, storage and computing cycles. Distributed computing serves as the core of grid computing. Using IP-based networks, a grid links hundreds or thousands of servers and desktop computers into a supercomputing engine capable of delivering massive amounts of computational power and other IT resources. Grid computing creates a distributed network of computers so that applications can share resources. In general, sharing can occur over diverse operating systems (e.g. Linux, Solaris, UNIX and Windows). The sharing involved in grid technologies is not primarily file exchange, but rather direct access to computers, storage, software, data and other resources. Some supporters – including HP, IBM, Sun Microsystems and Platform Computing – now say that grid computing is ready for primetime. But serious limits to the technology remain. Major hurdles for grid computing include non-functional system attributes such as security, reliability, execution latency, etc. Likewise, grid computing requires a communications infrastructure that can support large-scale sharing of data. Technical and economic concerns, including end-to-end security and usage metering, need to be addressed before widespread adoption is possible. Traditional business software is generally poorly suited for grid computing. However, new versions are being developed to harness grid power. The licensing of grid application business software is still an open issue. Some industries have successfully adopted grid computing

# International Journal of Innovative Research in Science, Engineering and Technology

(An ISO 3297: 2007 Certified Organization)

Website: [www.ijirset.com](http://www.ijirset.com)

Vol. 6, Issue 5, May 2017

technology. The financial services industry uses it for derivatives analysis, statistical analysts and portfolio risk analysis. The insurance industry uses it for certain tasks. Life sciences use grid technology to carry out cancer research and protein sequencing and folding.

## IV. CONGESTION CONTROL IN GRID

Congestion is an important issue that can arise in packet switched network. Congestion is a situation in Communication Networks in which too many packets are present in a part of the subnet, performance degrades. Congestion in a network may occur when the load on the network (*i.e.* the number of packets sent to the network) is greater than the capacity of the network (*i.e.* the number of packets a network can handle.)

### A. Causing of Congestion

The input traffic rate exceeds the capacity of the output lines. If suddenly, a stream of packet start arriving on three or four input lines and all need the same output line. In this case, a queue will be built up. If there is insufficient memory to hold all the packets, the packet will be lost. Increasing the memory to unlimited size does not solve the problem. This is because, by the time packets reach front of the queue, they have already timed out (as they waited the queue). When timer goes off source transmits duplicate packet that are also added to the queue. Thus same packets are added again and again, increasing the load all the way to the destination. The routers are too slow to perform bookkeeping tasks (queuing buffers, updating tables, etc.). The routers' buffer is too limited. Congestion in a subnet can occur if the processors are slow. Slow speed CPU at routers will perform the routine tasks such as queuing buffers, updating table etc slowly. As a result of this, queues are built up even though there is excess line capacity.

Congestion is an important issue that can arise in packet switched network. Congestion is a situation in Communication Networks in which too many packets are present in a part of the subnet, performance degrades. Congestion in a network may occur when the load on the network (*i.e.* the number of packets sent to the network) is greater than the capacity of the network (*i.e.* the number of packets a network can handle.) In this method of congestion control, congested router or node sends a special type of packet called choke packet to the source to inform it about the congestion. Here, congested node does not inform its upstream node about the congestion as in backpressure method. In choke packet method, congested node sends a warning directly to the source station *i.e.* the intermediate nodes through which the packet has traveled are not warned.

## V. CONGESTION CONTROL-GOVERNMENTGRIDSERVICES

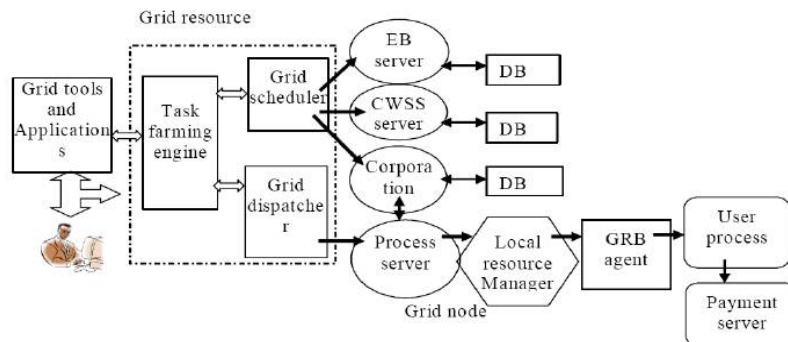

Figure 1: Interactions of Grid Resource Broker and the various components of e-governance applications

# International Journal of Innovative Research in Science, Engineering and Technology

(An ISO 3297: 2007 Certified Organization)

Website: [www.ijirset.com](http://www.ijirset.com)

Vol. 6, Issue 5, May 2017

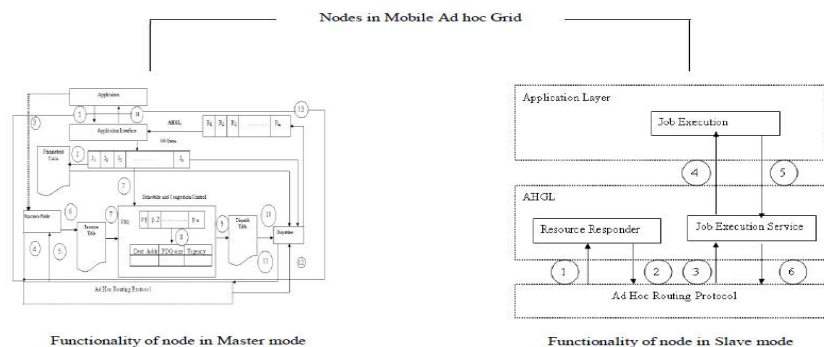
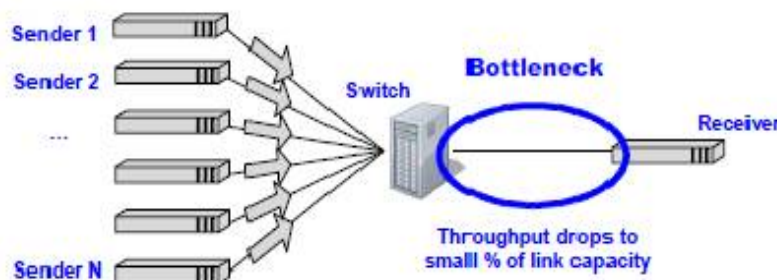

**Figure 2:** Functional Diagram of Master/Slave in Modified AHGL

The nodes in master mode of AHGL are responsible for scheduling and congestion control. The application interface service of AHGL divides the application into small grid jobs. The dynamic topology and mobility of mobile ad hoc grid not support the central register node to maintain the resource table. The free resources are discovered with On-demand resource discovery applied to AHGL at the moment jobs enter the mobile ad hoc grid, generates AHGL request packet and broadcast it to all available nodes. The minimum requirements to process the job are defined in the AHGL request packet. IDnode is the destination of the packet, SEQ used to distinguish different requests from the same node, CPU defines the required minimum speed of the processor in GHz, MEM defines the required minimum free memory and BAT is the required minimum amount of battery services. The resource response service monitors the available resources for a given node and responds to each AHGL request packet. It checks the sequence number SEQ of the request and compares the fields CPU, MEM, BAT from the request packet with the actual values from the node, if the values from the node are higher than criteria it satisfied AHGL response packet is generated and transferred to ad hoc network routing layer. The job execution service is activated when the jobs arrive at the slave node. The jobs are forwarded to the upper layer for execution and obtained results are transferred to the master mode.

## VI. RESULTS AND DISCUSSIONS

In E-governance many senders and receivers are communicating through the network backbone. The sender and receivers are transmitting Big Data in E-governance applications, which many cause some bottleneck usually such type of bottleneck problems are handled by congestion control algorithms.



**Figure :3** The receiver requests K blocks of data from a set of N storage servers.

Recent years have witnessed the emergence of e-governance application and services that generate massive collection of data also known as Big Data. To analyze the data quickly and efficiently, and extract value for citizens,

# International Journal of Innovative Research in Science, Engineering and Technology

(An ISO 3297: 2007 Certified Organization)

Website: [www.ijirset.com](http://www.ijirset.com)

Vol. 6, Issue 5, May 2017

these services use distributed frameworks Map/Reduce deployed in cloud environments the frameworks split the data across clusters of hundreds or thousands of computers analysis each piece in parallel, and the transfer and merge the results across the mobile Adhoc network. To reduce the running costs, it is important to improve cluster utilization and keep the duration of data processing jobs low. When Big Data is transmitted through the mobile ad hoc Grid, it is responsible to deal with the challenges in recourse discovery and job scheduling due to its mobility and power consumption. This proposed mobile adhoc grid technology can be applied for e-governance applications such as disaster management, wild fire fighting, e-health care and emergency. This proposed grid computing technique is implemented to manage the congestion control with job scheduling on e-governance application. The proposed addition of the mobile adhoc network with in AHGL can offer maximum network utility. The proposed model is implemented in the NS-2 network simulator.

## A. CONGESTION

Congestion in a network may occur if the load on the network- the number of packets sent to the network- is greater than the capacity of the network-the number of packets a network can handle. Congestion in a network or internet work occurs because routers and switches have queues- buffers that hold the packets before and after processing. It degrades quality of service and also can lead to delays, lost data. Congestion can be brought on by several factors. If all of a sudden, streams of packets begin arriving on three or four input lines and all need the same output line, a queue will build up. If there is insufficient memory to hold all of them, packet will be lost. This problem cannot be solved by increasing memory, because Nagle discovered that if routers have an infinite memory, congestion gets worse, not better. Slow processor can also cause congestion. If routers' CPUs are slow at performing the bookkeeping tasks required, queues can build up, even though there is excess line capacity. Similarly, low bandwidth lines can also cause congestion.

## B. CONGESTION CONTROL

Congestion control refers to the mechanism and techniques to control the congestion and keep the load below the capacity. It is a mechanism that can either prevent congestion, before it happens, or remove congestion, after it has happened. The objective of congestion control is to maintain the number of packets within the network below the level at which performance falls off dramatically. Due to the unpredictable fluctuations and burstiness of traffic flows within high speed network congestion can occur frequently. So this need efficient congestion control technique. There are many mechanisms developed for congestion control:

## C. ADAPTIVE CONGESTION CONTROL:

Adaptive congestion control is a mechanism with learning capability. This learning capability enables the mechanism to adapt to dynamically changing network conditions to maintain stability and good performance. In this a feedback is send to the sender to changeSending rate, according to the current network conditions. It is scalable with respect to changing delays, bandwidth and number of users utilizing the network.ACP is characterized by its learning capability which enables the protocol to adapt to the highly dynamic network environment to maintain stability and good performance. This learning capability is materialized by a novel estimation algorithm, which "learns" about the number of flows utilizing each link in the network. Previous experience in the design of congestion control algorithms has shown that at each link, the number of flows utilizing the link is necessary in order to maintain stability in the presence of delays.

## D. RATE CONTROL PROTOCOL:

Rate Control Protocol (RCP) is a congestion control algorithm designed for fast download times. RCP is designed for the typical flows of typical users in the Internet today. RCP has two components:(1)End-host congestion control layer that sits between IP and TCP/UDP. During introduction, the end-host could adapt by testing for RCP at each end and along thepath, falling back to TCP if need-be (2) Each router maintains a single fair-share rate per link

# International Journal of Innovative Research in Science, Engineering and Technology

(An ISO 3297: 2007 Certified Organization)

Website: [www.ijirset.com](http://www.ijirset.com)

Vol. 6, Issue 5, May 2017

## E. EXPLICIT CONGESTION CONTROL PROTOCOL:

XCP is a window based congestion control protocol intended for best effort traffic. Senders maintain their congestion window and RTT and communicate this to routers via a congestion header in every packet. Sender uses the feedback field in the congestion header to request its desired window increase. Routers monitor the input traffic rates to each of their output queues. Based on the difference between the link bandwidth and its input traffic, router tells the flows sharing that link to increase or decrease their congestion window.

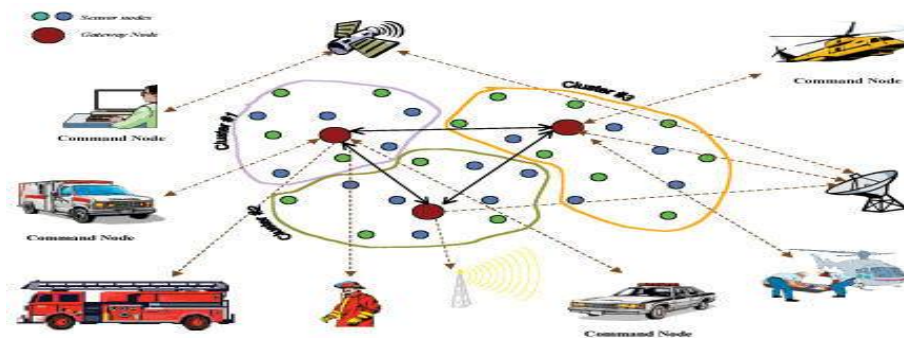
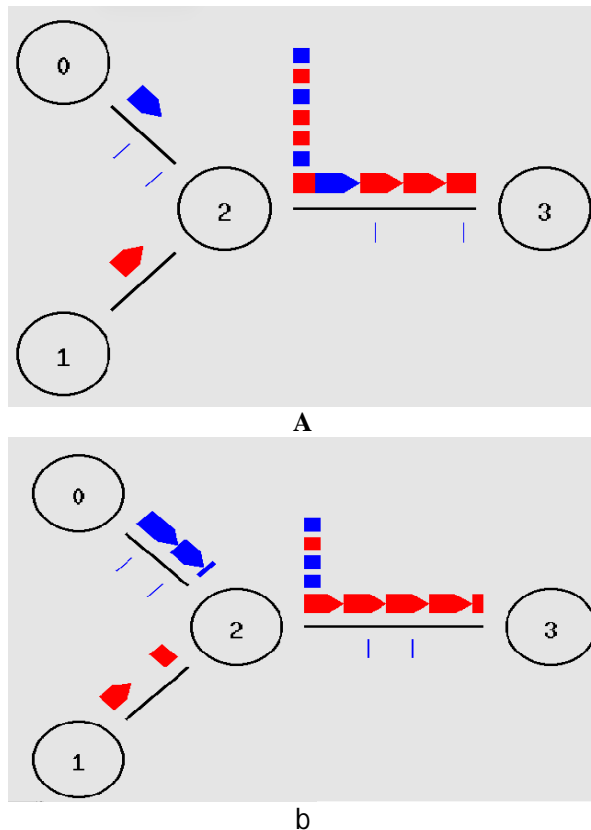

Figure :4An example mobile adhocnetwork topology for e-governance application.



# International Journal of Innovative Research in Science, Engineering and Technology

(An ISO 3297: 2007 Certified Organization)

Website: [www.ijirset.com](http://www.ijirset.com)

Vol. 6, Issue 5, May 2017

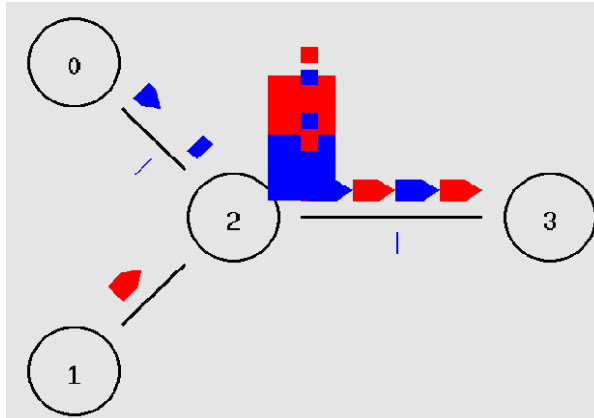

C

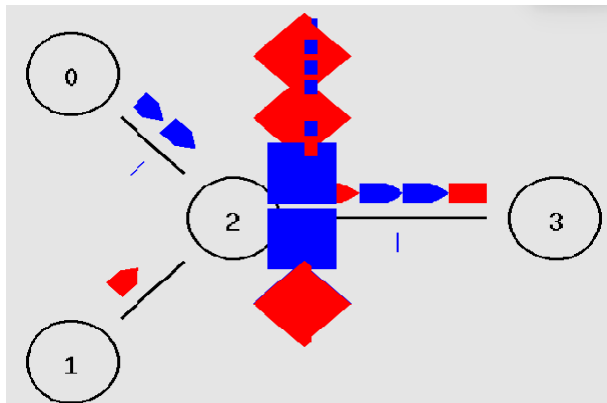

e

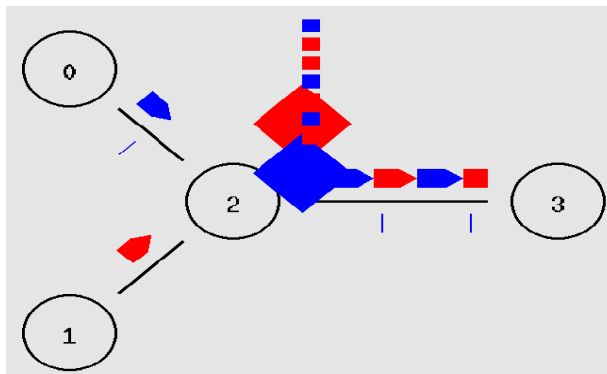

D

# International Journal of Innovative Research in Science, Engineering and Technology

(An ISO 3297: 2007 Certified Organization)

Website: [www.ijirset.com](http://www.ijirset.com)

Vol. 6, Issue 5, May 2017

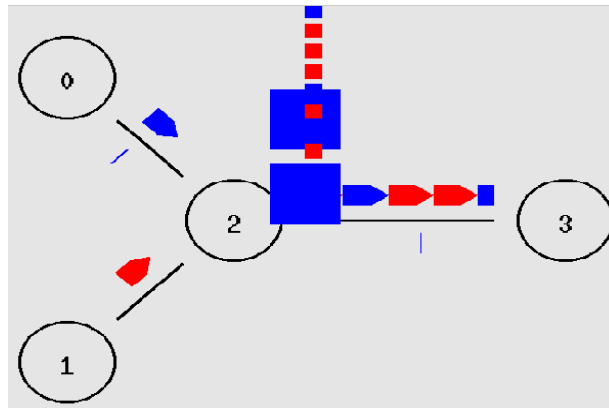

f

Figure 5: Represents the traffic on a single mobile node in the mobile adhoc network topology within 10 Second

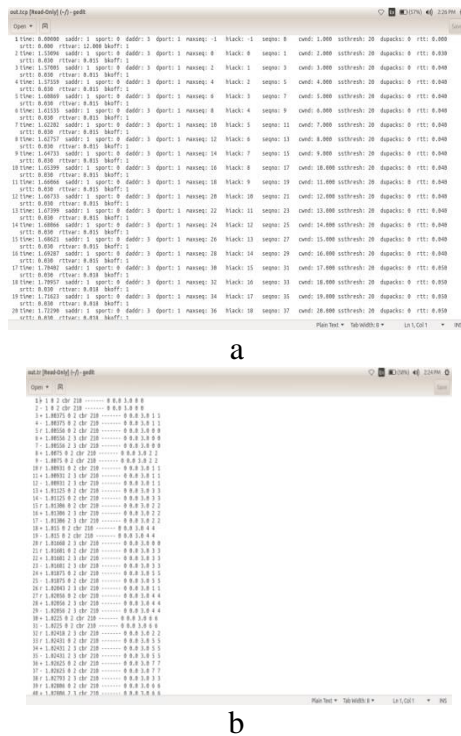

a

b



# International Journal of Innovative Research in Science, Engineering and Technology

(An ISO 3297: 2007 Certified Organization)

Website: [www.ijirset.com](http://www.ijirset.com)

Vol. 6, Issue 5, May 2017

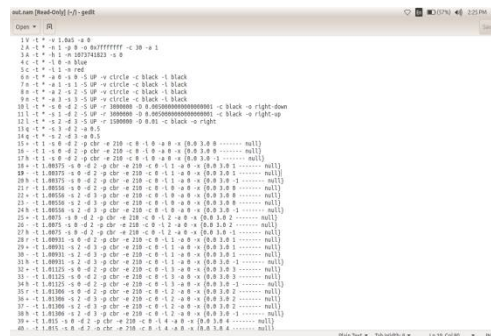

C

Figure 6: Congestion Control Implementation of mobile adhoc network.

The analysis on joint scheduling and congestion control in AHGL is done by implementation with NS-2 network simulator. The FindResource agent and ExecuteTask agent are derived from the Agent super class. The agent is responsible to track the specific characteristics of the node during its activation. The existing routing and other lower level protocols do this process. The simulation starts on each node with the FindResource agent. The FindResource is responsible to flood the ad hoc network broadcasting a resource request packet, when the node is in master mode. The node receives the corresponding reply packet, the agent updates the resource table. The FindResource agent is activated in slave mode is programmed to construct a reply packet, which are satisfying the needed characteristics defined by the request packet. The reply packet is sent to the node in master mode and it continues the network flooding process. The tcl simulation class does the joint scheduling and congestion control. The tcl class identifies the channel rate, packet size and PDQ size. By using the channel rate for the packets in PDQ and depends upon the urgency it performs inter and intra scheduling to manage congestion

## VII. CONCLUSION

This paper has identified and discussed a new virtual environment by using mobile ad hoc grid technologies to a specific e-governance application on distributed resources. This paper also presents a joint congestion control and scheduling algorithm implementation in virtual environment of the e-governance applications. The virtual environment with congestion control in capable to adapt the dynamic environment and achieves high fault tolerance rate. This paper concludes the joint congestion control and scheduling algorithm implemented in AHGL increases the scalability and speed of the job execution process in virtual environment for e-governance. This proposed system will lead that an e-governance solution with cost effective, efficient, consistent and reduced job processing time with high quality of result and providing better services to citizen.

## REFERENCES

- [1] R. Bhaskaranand .Madheswaran, 'Performance Analysis of congestion control in mobile Adhoc grid layer', (2010)
- [2] D. G. Iyana, (Corresponding Author), L.A. Ogundele, O.A. Oyedemi, 'Grid Computing: A Desirable Tool for Electronic Governance', 2014.
- [3] Mr. Rajesh Kain, 'Importance of grid computing in E-Government Activity', August 2016.
- [4] UmmiAzizahRachmawati and HeruSuhartanto, 'Analysis of Indonesia E-Government grid services simulation based on population', (2014).
- [5] S.Gowri, N.Ramadevi, S.Vijayalakshmi, 'Grid Computing Technologies', December 2015.
- [6] Hanaa. M. Said, MohamedHamdy, RainaeiGohary and M. Salem, 'Intelligence Techniques for e-government applications', March-April 2015.
- [7] Congestion Control of Smart Distribution Grids using State Estimation Abishek S, Non-Member, IEEE, and BalakrishnanNarayanawamy Member, IEEE