

International Journal of Innovative Research in Science, Engineering and Technology

(A High Impact Factor, Monthly, Peer Reviewed Journal)

Visit: www.ijirset.com

Vol. 6, Issue 10, October 2017

Blind Channel Estimation in Multicellular OFDM Systems

Karthika S

Department of Electronics Engineering, Madras Institute of Technology, Chennai, Tamilnadu, India

ABSTRACT: The aim of this paper is to compare the performance of Blind channel Estimation in OFDM with pilot based channel estimation. A blind channel estimation is presented for uncoded OFDM. In this method, four steps is done. The four steps are decision algorithm, channel impulse response estimation, channel frequency response estimation and data recovery. The decision algorithm first makes the primary estimates based on minimum mean square criteria. Then these primary estimates are applied to MMSE channel estimation. At last hard decision block is used to recovered the transmitted signal by setting the optimum thresholds in the constellation regions. From the second OFDM symbol $H[2,k]$ the algorithm switches to blind channel estimation and uses the channel estimates of first symbol is at hand. The first OFDM symbol is assumed by using any pilot based channel estimation. Bit Error Rate(BER) Performance (fade rate= $0.015\mu\text{s}$ and TOFDM = $4\mu\text{s}$) of Blind channel estimation(BCE) in OFDM is compared with the known technique such as block type pilot based channel estimation. Normalized Mean Square Error(NMSE) of the 1st iteration(fade rate= $0.015\mu\text{s}$ and TOFDM = $4\mu\text{s}$ and SNR 20dB) is same for both technique such as block type and blind channel estimation. After that NMSE decreases for BCE when compared to other technique. BER performance for the BCE and other technique is calculated when Doppler frequency increases for the constant Signal to Noise Ratio (SNR) 20 dB.

KEYWORDS: channel estimation, MMSE, OFDM, Pilot channel estimation

I. INTRODUCTION

During the past few years, there has been an explosion in wireless technology. This growth has opened a new dimension to future wireless communications whose ultimate goal is to provide universal personal and multimedia communication without regard to mobility or location with high data rates. To achieve such an objective, the next generation personal communication networks will need to be support a wide range of services which will include high quality voice, data, facsimile, still pictures and streaming video. These future services are likely to include applications which require high transmission rates of several Mega bits per seconds (Mbps).

In the current and future mobile communications systems, data transmission at high bit rates is essential for many services such as video, high quality audio and mobile integrated service digital network. When the data is transmitted at high bit rates, over mobile radio channels, the channel impulse response can extend over many symbol periods, which leads to Inter-symbol interference (ISI). Orthogonal Frequency Division Multiplexing (OFDM) is one of the technique to mitigate the ISI. In an OFDM signal the bandwidth is divided into many narrow sub-channels which are transmitted in parallel. Each sub-channel is typically chosen narrow enough to eliminate the effect of delay spread.

Orthogonal Frequency Division Multiplexing describes briefly in [1]. The basics of communication standards and Tapped Delay Line explains in [2]. Fundamentals of Adaptive Filtering [3] explains Autoregressive models(AR) and Tapped Delay Line(TDL). OFDM has broad uptake in wireless communications. The structure of OFDM is still evolving as new technology and in many applications. OFDM is best for dispersive channels. OFDM optimized over various components such as partitioning [1], adaptive loading [4] and coding[1]. These optimizations techniques depends on the channel. The channel modeling is very critical. The channel can be estimated by pilot manner or in blind manner. Adding training sequences in the time or frequency domain estimates the channel frequency response. The channel response(CR) at the other positions can be estimated by interpolation. This schemes not only reduces

International Journal of Innovative Research in Science, Engineering and Technology

(A High Impact Factor, Monthly, Peer Reviewed Journal)

Visit: www.ijirset.com

Vol. 6, Issue 10, October 2017

payload capacity but also increases complexity. Many pilot based channel estimation for channel estimation is given in the paper[5] – [7].

Pseudopilot algorithm[5] based on autoregressive model based on least square estimation for fast varying channel without increasing the pilot. Blind and semiblind channel identification methods using second order statistics for OFDM systems [8] and [4] explains about statistical blind channel estimation include cumulant fitting and correlation methods. Some algorithms based on subspace decomposition are proposed in [8] which takes advantage of the inherent redundancy introduced by CP to blindly estimate the channel. Channel estimation/Tracking based on kalman filtering [9] is also well established. Deterministic blind channel estimation using Maximum likelihood is proposed in [10-12] takes advantage of producing a channel estimate from a single OFDM symbol, but high complexity is needed to execute the maximization in the algorithm, and there is an ambiguity in recovered phase.

II. RELATED WORKS ABOUT CHANNEL ESTIMATION METHODS

A. Introduction

A wideband radio channel is normally frequency selective and time variant. For an OFDM mobile communication system, the channel transfer function at different subcarriers appears unequal in both frequency and time domains. Therefore, a dynamic estimation of the channel is necessary. Pilot-based approaches are widely used to estimate the channel properties and correct the received signal. In this chapter we have investigated about channel estimation.

For burst communication system, training symbols are used at the beginning of each burst. Since the burst is short, the channel is assumed static over a whole burst so that once the channel is estimated, the inverse of the estimated channel response will be used to compensate the signal for the whole burst.

Assuming the received signal after FFT is

$$Y(k) = C(k)X(k) + Z(k) \quad (1)$$

where k is sub-carrier index, C is the channel, X is the pilot data, and Z is the noise. The simplest way to estimate the channel is then by

$$C(k) = x(k) / y(k) \quad (2)$$

i.e. dividing the received signal by the known pilot. Without noise, this gives the correct estimation. When noise is present, there could be error.

The channel can be estimated either by the use of pilot symbols or in a blind manner. Adding training sequence pilots or carrier pilots in the time or frequency domain enables estimation of the channel response (CR) at the pilot positions. The CRs at the other positions can be estimated by interpolation. Pilot schemes not only require reduction in the available payload capacity but also add much complexity—both the receiver and transmitter must have built-in a priori knowledge of the pilot scheme, and both must deploy the extra processing to implement the pilot scheme. (For compatibility, the standards must also enumerate the complexity and tolerance of the pilot scheme.) Nevertheless, this condition is the status quo, because the link performance cannot currently be realized by other means.

B. Pilot Channel Estimation

The first one, block-type pilot channel estimation, is developed under the assumption of slow fading channel, and it is performed by inserting pilot tones into all subcarriers of OFDM symbols within a specific period. The second one, comb-type pilot channel estimation, is introduced to satisfy the need for equalizing when the channel changes even from one OFDM block to the subsequent one. It is thus performed by inserting pilot tones into certain subcarriers of each OFDM symbol, where the interpolation is needed to estimate the conditions of data subcarriers.

C. Types of channel estimator

1) LS Estimator

The LS estimator minimizes the parameter $(Y-XH)^H(Y-XH)$ where $(\cdot)^H$ means the conjugate transpose operation. It is shown that the LS estimator of is given by

$$H'_{LS} = X^{-1}Y = [(X_k/Y_k)]^T \quad k=0, \dots, N-1 \quad (3)$$

International Journal of Innovative Research in Science, Engineering and Technology

(A High Impact Factor, Monthly, Peer Reviewed Journal)

Visit: www.ijirset.com

Vol. 6, Issue 10, October 2017

Without using any knowledge of the statistics of the channels, the LS estimators are calculated with very low complexity, but they suffer from a high mean-square error.

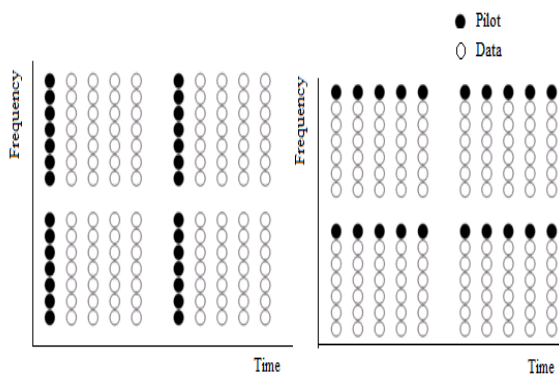

Fig. 1 Pilot channel estimation

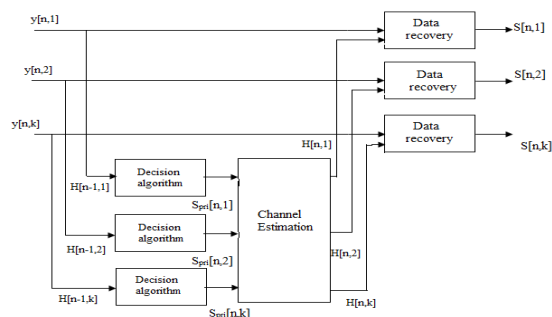

Fig. 2 Block diagram for blind channel estimation after FFT

2) MMSE Estimator and Modified MMSE Estimator

The MMSE estimator employs the second-order statistics of the channel conditions to minimize the mean-square error.

Denote by R_{gg} , R_{HH} and R_{YY} the auto covariance matrix of g , H and Y respectively and R_{gY} be the autocovariance matrix of g and y . Also denote by σ_N^2 the noise variance $E\{|N|^2\}$. Assume the channel vector g and noise N are uncorrelated, it is derived by

$$R_{HH} = E\{|HH^H\} = E\{(Fg)(Fg)^H\} = F R_{gg} F^H \quad (4)$$

$$R_{gY} = E\{gY^H\} = E\{g(XFg+N)^H\} = R_{gg} F^H X^H \quad (5)$$

$$R_{YY} = E\{YY^H\} = XF R_{gg} F^H X^H + \sigma_N^2 I_N \quad (6)$$

Assume R_{gg} and σ_N^2 are known at the receiver in advance, the MMSE estimator of g is given by $g_{MMSE} = R_{gY} R_{YY}^{-1} Y^H$. Note that g is not Gaussian, g_{MMSE} is not minimum mean square estimator but it is still the best linear estimator in the mean-square error sense. At last, it is calculated that

$$\begin{aligned} H_{MMSE}^* &= F g_{MMSE} = F[(F^H X^H)^{-1} R_{gg}^{-1} \sigma_N^2 + XF]^{-1} Y \\ &= F R_{gg} [(F^H X^H XF^{-1}) \sigma_N^2 + R_{gg}]^{-1} Y \\ &= R_{HH} [R_{HH} + \sigma_N^2 (XX^H)^{-1}]^{-1} H_{LS} \quad (7) \end{aligned}$$

The MMSE estimator yields much better performance than LS estimators, especially under the low SNR scenarios. A major drawback of the MMSE estimator is its high computational complexity, especially if matrix inversions are needed each time the data in X changes.

Modified MMSE estimators are studied widely to reduce . Among them, an optimal low-rank MMSE (OLR-MMSE) estimator is proposed in this paper, which combines the following three simplification techniques:

a) The first simplification of MMSE estimator is to replace the term $\{XX^H\}^{-1}$ in Equation (8) with its expectation $E\{XX^H\}^{-1}$. Assuming the same signal constellation on all tones and equal probability on all constellation points, we have

$$E\{XX^H\}^{-1} = E\{|X_k|^2\} I \quad (8)$$

Defining the average SNR term as $SNR = E\{X_k^2/\sigma_N^2\}$, and the term $\beta = E\{|X_k|^2\} / E\{|1/X_k|^2\}$. The term σ_N^2 is then approximated by $(\beta / SNR)I$, β is constant depending only on the signal constellation. For example 16 QAM transmission $\beta=17/9$.

b) The second simplification is based on the singular value decomposition(SVD). The SVD of R_{HH} is UAU^H , where U is a unitary matrix containing the singular vectors and the Λ is the diagonal matrix containing singular values $\lambda_0 > \lambda_1 > \dots > \lambda_{N-1}$ on its diagonal. The SVD dramatically reduces the calculation complexity of matrices.

International Journal of Innovative Research in Science, Engineering and Technology

(A High Impact Factor, Monthly, Peer Reviewed Journal)

Visit: www.ijirset.com

Vol. 6, Issue 10, October 2017

Combining all simplification techniques, the OLR-MMSE estimator is explained as follows. The system first determines the number of ranks required by the estimator, denoted by p , which should be no smaller than $(L + 1)$. Then, given the signal constellation, the noise variance and the channel autocovariance matrix. RHH the receiver pre-calculates β , SNR, the unitary matrix U and the singular values λ . It thus obtained the $(N \times N)$ diagonal matrix with Δ_p entries

$$\delta_k = \begin{cases} [\lambda_k / \lambda_k (\beta / SNR)] & k = 0, 1 \dots p-1 \\ 0 & k = 0, 1 \dots N-1 \end{cases} \quad (9)$$

$$H_{OLR-MMSE} = U \Delta_p U^H H_{LS} \quad (10)$$

The OLR-MMSE estimator can be interpreted as first projecting the LS estimates onto a subspace and then performing the estimation. Because the subspace has a small dimension (as small as $(L + 1)$ and still describes the channel well, the complexity of OLR-MMSE estimator is much lower than MMSE estimator with a good performance. However, the low-rank estimators introduce an irreducible error floor due to the part of the channel that does not belong to the subspace.

4) Maximum Likelihood Estimator

Most of the energy in g is contained in, or near, the first $(L + 1)$ taps, where $L = [T_G/T_S]N$. Define $g_{L+1} = [g_0 \dots g_{L+1}]$ is the first $(L + 1)$ taps of g . Similarly to the definition of the square DFT matrix F , we define the non-square DFT matrix

$$F_{A,B} = [W_N^{a,b}]_{A \times B} \quad (0 < a < A, 0 < b < B) \quad (11)$$

Also, we define the uniform-spaced-DFT matrix with space S as follows:

$$F(S)_{A,B} = [W_N^{as,b}]_{A \times B} \quad (0 < a < A, 0 < b < B) \quad (12)$$

It is obvious that $H_p = F(S) N_p \times (L+1) g_{L+1}$ where S is the space between pilot subcarriers. Thus, the maximum likelihood estimator (MLE) of g_{L+1} given the estimate to H_p is obtained by

$$g_{L+1} = (F(S)_{N_p, L+1}^H \times F(S)_{N_p, L+1})^{-1} F(S)_{N_p, L+1} H_{LS}^p \quad (13)$$

Finally, the complete channel estimate H' of all the subcarriers is computed from given by

$$H'_{MLE} = F_{N, L+1} g_{L+1} \quad (14)$$

5) Existing Blind Channel Estimation

Existing blind channel estimation methods for OFDM systems can be classified as statistical or deterministic. Examples of statistical blind channel estimation include using correlation methods and cumulant fitting. These statistical approaches exhibit slow convergence, making them unsuitable for mobile radio channels or any burst transmission. Another blind equalization criterion has been introduced. It does not apply to traditional OFDM systems, because it relies on a transmitter without cyclic prefix (CP). In addition, correlation matching methods based on the transmitted signal cyclostationarity. However, their possible implementation in existing systems is complicated in practice by the presence of null side carriers that affect the proposed identification results. Some algorithms based on subspace decomposition which essentially take advantage of the inherent redundancy introduced by the CP to blindly estimate the channel. To avoid the convergence period of the blind subspace algorithms, during which the estimation is unreliable, known pilots are transmitted at the beginning of each OFDM frame. These methods are sometimes referred to as semiblind, despite the need for pilots.

III. PROPOSED SYSTEM

Instead of using pilot to estimate the channel, decision algorithm to find the primary estimates of the data symbol of each subcarrier based on the minimum mean square error criteria. Then these estimates are applied to MMSE channel estimation. After that data recovered by using hard decision decoding. In this all subcarriers are used for data transmission. The total number of samples is associated with each OFDM symbols including both data samples and cyclic prefix (CP) is 80. The BER performance of Blind channel estimation is compared with the block type pilot

International Journal of Innovative Research in Science, Engineering and Technology

(A High Impact Factor, Monthly, Peer Reviewed Journal)

Visit: www.ijirset.com

Vol. 6, Issue 10, October 2017

channel estimation. Normalized mean square error (NMSE) of blind channel estimation is compared. Comparison of the upper bound for aggregate data transmission rate in bits per second per hertz for blind estimation and the pilot-based systems, with uncoded square QPSK modulation on each subcarrier is done.

1) Channel Model

The n th OFDM symbol time, N data symbols $\{s[n,k]\} k=1,2,\dots,N-1$ are converted into time domain using IFFT. The CP of length P , consumes payload capacity is needed to preserve orthogonality between subcarriers and to eliminate the Inter Symbol Interference (ISI). The OFDM symbol time is defined as $T_{\text{OFDM}} = (N+P)T_s$, T_s be the duration of the input data symbol. The baseband representation of the channel impulse response is given as

$$h(t, \tau) = \sum_{m=1}^M h_m(t) \delta(\tau - \tau_m) \quad (15)$$

where τ_m is the delay of the m th tap, M is the number of taps and the $h_m(t); m=1, \dots, M$. the time varying channel taps have the same autocorrelation functions is

$$R_{h_m}(\Delta t) = \sigma_{h_m}^2 \rho(\Delta t) \quad (16)$$

where $\sigma_{h_m}^2$ be the corresponding channel branch coefficients variances and $\rho(\Delta t)$ being the normalized time correlation function. For simulation $J_0(2\pi f_D \Delta t)$ where f_D is the maximum Doppler frequency.

The frequency correlation coefficient function is given as

$$\rho_H(\Delta t) = \sum_m \frac{\sigma_{h_m}^2}{\sigma_H^2} e^{-j2\pi \Delta f \tau_m} \quad (17)$$

The received waveform is sampled at $t=kT_s$ and CP is removed before the FFT. The received OFDM symbol of the k th subcarrier at the n th OFDM symbol time can be represented by

$$y[n,k] = H[n,k] s[n,k] + v[n,k] \quad (18)$$

where $H[n,k]$ is the frequency response of the channel at the k th subcarrier and the n th OFDM symbol time and $v[n,k]$ is the zero mean white Gaussian noise with variance σ_v^2 .

2) Blind Channel Estimation And Data Recovery

Equation 18 is written in matrix form as

$$y_n = \Lambda_n s_n + v_n \quad (19)$$

where $y_n = [y[n,1] \ y[n,2] \ \dots \ y[n,N]]^T$
 $s_n = [s[n,1] \ s[n,2] \ \dots \ s[n,N]]^T$
 $v_n = [v[n,1] \ v[n,2] \ \dots \ v[n,N]]^T$ and Λ_n is a diagonal matrix of $H[n,k]$. The block diagram for blind channel estimation in ofdm is given in the Figure 2.

Based on the channel frequency response correlation function at $\Delta t = (N+P)T_s$ and $\Delta f = 0$, $\rho(T_{\text{OFDM}}) = \sigma_H^2(T_{\text{OFDM}})$, the relation between $H[n,k]$ and $H[n-1,k]$ can be approximated by the AR process as follows

$$H[n,k] = \rho(T_{\text{OFDM}}) H[n-1,k] + \sigma_H \sqrt{1 - |\rho(T_{\text{OFDM}})|^2} w[n,k] \quad (20)$$

For the k th subcarrier at the $(n-1)$ th OFDM symbol interval, then the channel estimation is given as

$$H'[n-1,k] = H[n-1,k] + \sigma_{Hk}[n-1] \omega_{Hk}[n-1] \quad (21)$$

Considering Equation (20) and (21), then $y[n,k]$ is given as

$$y[n,k] = \rho(T_{\text{OFDM}}) H'[n-1,k] s_{\text{pri}}[n,k] + v'[n,k] \quad (22)$$

where

$$v'[n,k] = v[n,k] + \sigma_H \sqrt{1 - |\rho(T_{\text{OFDM}})|^2} \omega[n,k] s_{\text{pri}}[n,k] - \rho(T_{\text{OFDM}}) \sigma_{Hk}[n-1] \omega_H[n-1] s_{\text{pri}}[n,k]$$

The Equation (22) can be written as

$$y[n,k] = (\rho(T_{\text{OFDM}}) H'[n-1,k] s_{\text{pri}}[n,k]) g + v'[n,k] \quad (23)$$

$C = \{s_1, s_2, \dots, s_L\}$ to be the set of transmitted signal constellation points with set size $|C| = L$, the primary estimates of symbol $s[n,k]$ is

$$S_{\text{pri}}[n,k] = \arg \min (|g - g_j|^2) \quad k=1, \dots, N \quad (24)$$

where $g_j, j=1, \dots, L$ is the unbiased MMSE estimator is given by

$$g_j = y[n,k] / f_j \quad j=1, \dots, L \quad (25)$$

where $f_j = \rho(T_{\text{OFDM}}) H[n-1,k] s_j$

Thus the MMSE estimator of h_n is obtained as

$$h_n = (A^{-1} + \frac{1}{\sigma_v^2} Q^H S_{\text{pri}}^H S_{\text{pri}}^H Q)^{-1} (\sigma_v^2)^{-1} Q^H S_{\text{pri}}^H y_n \quad (26)$$

International Journal of Innovative Research in Science, Engineering and Technology

(A High Impact Factor, Monthly, Peer Reviewed Journal)

Visit: www.ijirset.com

Vol. 6, Issue 10, October 2017

with $A = \text{diag} \{[\sigma_{h1}^2 \ \sigma_{h2}^2 \ \dots \ \sigma_{hm}^2]\}$ and the channel covariance matrix is

$$C_{hh} = (A^{-1} + \frac{1}{\sigma_s^2} Q^H S_{pri}^H S_{pri} Q)^{-1} \quad (27)$$

The MMSE estimator of s_n is given by

$$S[n,k] = \frac{H^*[n,k]}{\text{var} + |H[n,k]|^2} y[n,k] \quad (28)$$

Finally MMSE estimator of the channel frequency response is

$$H' = [H'[n,1] \ H'[n,2] \ \dots \ H'[n,N]]^T \quad (29)$$

Now the matrix inversion in Equation (4.12) is given as

$$h'_n = B' Q_{pri}^H S_{pri}^H y_n \quad (30)$$

with $B' = \text{diag} \{ [\sigma_{h1}^2 / (E_s \sigma_{h1}^2 + \sigma_v^2) \ \dots \ \sigma_{hm}^2 / (E_s \sigma_{hm}^2 + \sigma_v^2)] \}$

Finally by substituting $H'[n,k]$ in Equation (28) the estimates of transmitted signal is obtained. The hard decision block gives the detected symbols by setting the optimum thresholds in the constellation regions of the transmitted signal. The channel estimates is obtained from Equation (29) helps the decision algorithm in the subsequent (n+1)th iteration to obtain the next set of primary estimates. For the initialization of algorithm i.e. the first set of OFDM symbols are set by using any pilot based channel estimation. For second OFDM symbols $H[2,k]$ switches to blind channel estimation with $H[1,k]$ is at hand.

IV. SIMULATION RESULTS

Consider an uncoded OFDM systems that essentially follows IEEE 802.11 1 and 802.11g standards configurations. In the simulations, the number of subcarriers is $N = 64$, all subcarriers are used for data transmission. The length of cyclic prefix (CP) is $P = 16$, therefore the total number of samples associated with each OFDM symbol including both the data and CP is $N + P = 80$. The maximum delay spread for which the ISI is removed is τ_{max} . It is given as $PT_s = 0.8\mu s (T_s = 0.05\mu s)$. The OFDM symbol time is $T_{OFDM} = (N + P)T_s = 4\mu s$. The transmitted signals are modulated by using Quadrature Phase Shift Keying (QPSK). The value of $J_0(2\pi f_D T_{OFDM})$ are assumed to be known. The level of amplitude fluctuation of OFDM signals is usually measured in terms of peak factors that indicate the ratio of the peak power to the average envelope power of the signal. The transmitted OFDM signal is shown in the Figure 3. The transmit spectrum mask is the power contained in a specified frequency bandwidth at certain offsets, relative to the total carrier power. The transmit spectrum is plotted Frequency in MHz and Power spectral density is shown in the Figure 4. Power spectral density (PSD) is a positive real function of a frequency variable associated with a stationary stochastic process, or a deterministic function of time, which has dimensions of power per hertz (Hz), or energy per hertz. It is often called simply the spectrum of the signal. Intuitively, the spectral density measures the frequency content of a stochastic process and helps identify periodicities. It describes how the power of a signal or time series is distributed with frequency.

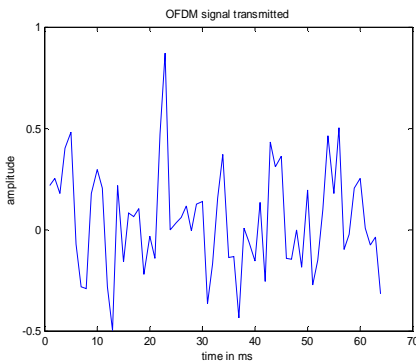

Fig. 3 OFDM transmitted signal

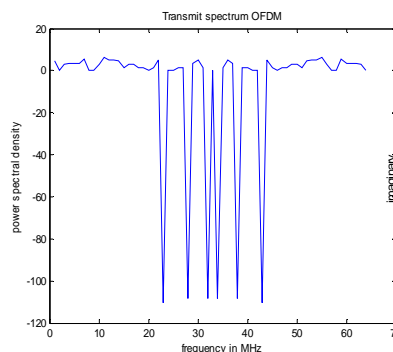

Fig.4 Transmit Spectrum of OFDM

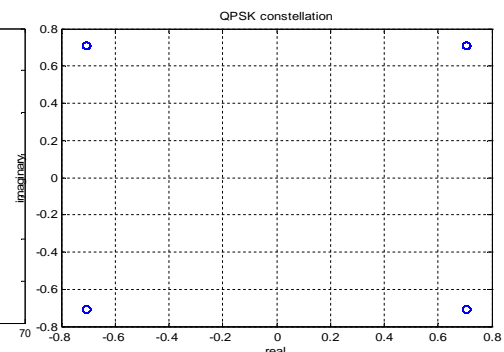

Fig.5 QPSK constellation

The QPSK constellation is plotted in the Figure 5. QPSK constellation is plotted real part and imaginary parts of QPSK symbols. QPSK symbols is plotted in the Figure 6. The transmitted signal is modulated by using QPSK modulation. The

International Journal of Innovative Research in Science, Engineering and Technology

(A High Impact Factor, Monthly, Peer Reviewed Journal)

Visit: www.ijirset.com

Vol. 6, Issue 10, October 2017

channel used in this simulation is Rayleigh channel. The number of taps is used here is 3. Gain is multiplied with the each tap. Then in receiver side all paths should be added. The added path is to multiplied with the variance. The Rayleigh channel with variance 0.5 is shown in the Figure 7. The channel tap variances are assumed to be known. The goal is to compare the behavior of blind channel estimation with the pilot based channel estimation. The received samples with noise is plotted in the Figure 8.

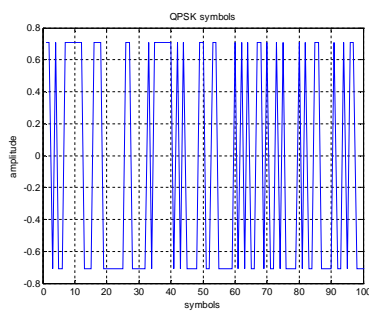

Fig.6. QPSK Symbols

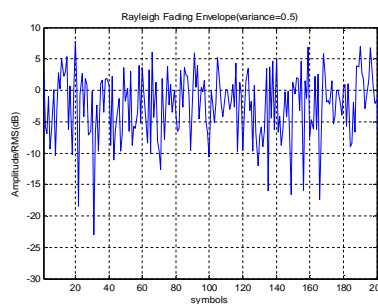

Fig. 7. Rayleigh Fading Envelope

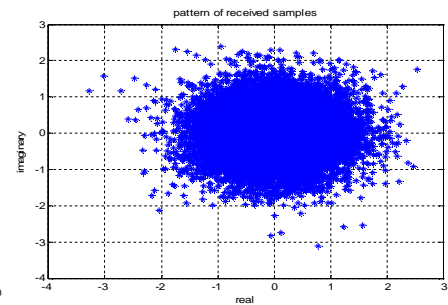

Fig.8 Pattern of Received samples

The BER performance of blind channel estimation is plotted in the Figure 9. In the Figure 10 BER performance of pilot based channel estimation is plotted in the Figure 10.

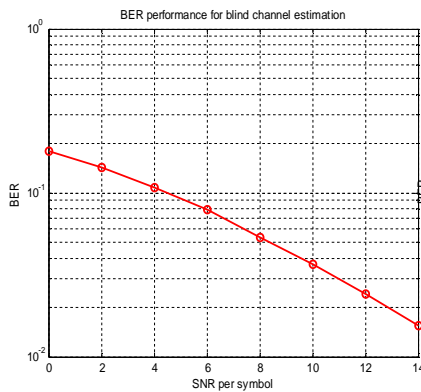

Fig.9 BER Performance for blind channel estimation fade rate=0.015 μs

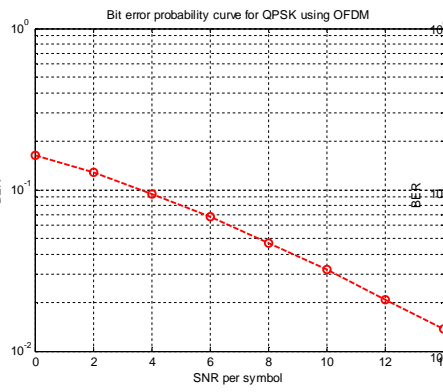

Fig.10 BER Performance for block type channel estimation fade rate =0.015 μs and $T_{OFDM} = 4\mu s$

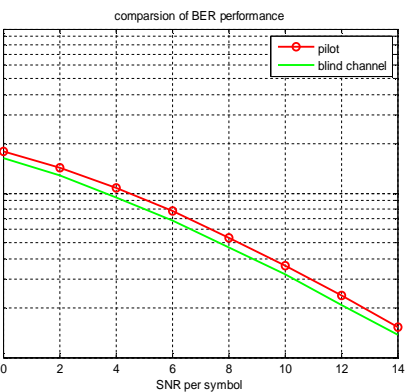

Fig.11 Comparison of BER performance of OFDM systems

The bit error rate performance based on the simulation is compared with pilot based method. In the block type pilot system, OFDM channel estimation symbols are periodically transmitted. Here each block is consists of a fixed number of OFDM symbols. Pilot are sent in all subcarriers of the first OFDM symbol of each block and the channel estimated at the beginning of the block is used for all the following OFDM symbols. Figure 11 illustrates the Comparison of BER performance of OFDM systems for fade rate=0.015μs, $f_D = 3750$ Hz and an SNR range 0-14 dB. The performance of estimation techniques by setting the normalized mean square error (NMSE) as a measure for estimating the channel frequency response. Here Monte carlo runs are carried out and NMSE at the nth iteration is defined as,

$$NMSE(n) = \frac{1}{MN} \sum_{m=1}^M \sum_{k=1}^N |H_m'[n,k] - H[n,k]|^2 \quad (30)$$

where $H_m'[n,k]$ denotes the estimates of $H[n,k]$ at the mth Monte carlo runs. The NMSE performance is shown in the Figure 12. The upper bound for the approximate aggregate number of payload bits per second per Hertz for a general OFDM systems is

$$R = \frac{1}{N+P} \log_2 \left(\prod_{k=1}^N \left(1 + \frac{SNR_k}{\Gamma} \right) \right) \quad (31)$$

where N is the number of subchannels, and P is the CP length. Γ is called SNR gap which is given as

International Journal of Innovative Research in Science, Engineering and Technology

(A High Impact Factor, Monthly, Peer Reviewed Journal)

Visit: www.ijirset.com

Vol. 6, Issue 10, October 2017

$$\Gamma = \frac{SNR}{2^{2R}-1} \quad (32)$$

where R is the rate in bits per second per hertz.

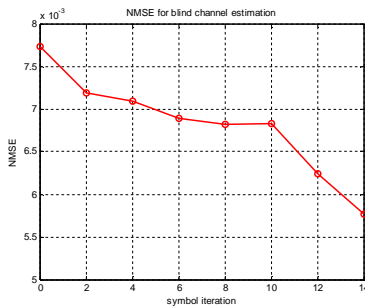

Fig. 12. NMSE performance for blind channel estimation

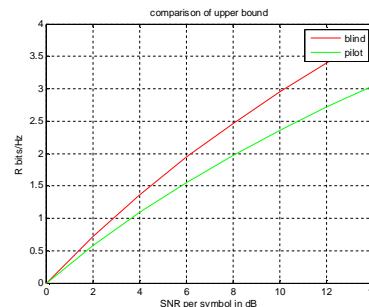

Fig.13 Comparison of the upper bound for aggregate data transmission rate in bits per hertz for blind estimation and block type channel estimation

The upper bound for the uncoded rate of the blind channel estimation is compared with the block type channel estimation is given in the Figure 13 and it shows blind channel estimation and pilot based estimation behave similarly. In fact, the blind channel estimation systems outperforms the pilot systems by up to a few decibels in SNR. This shows that better capacity efficiency.

V. CONCLUSION AND FUTURE WORK

In this project work, a blind channel estimation for OFDM has been formulated and its performance is compared with the other types of channel estimation such as Block type channel estimation. The simulated OFDM follows the IEEE 802.11 standards. The blind channel estimation is more spectrally efficient than pilot based channel estimation for the range of simulated channels. The upper bound for aggregate data transmission rate in bits per second per Hertz for blind estimation and block type channel estimation are compared. This results shows that the better capacity efficiency when compared to block type channel estimation.

Future work is Bit Error Rate performance is to be calculated when Doppler frequency increases. The impact of channel taps cross correlation coefficient on BER performance at certain SNR values and fade rate is to be calculated.

REFERENCES

- [1] S. Chen and S. McLaughlin, "Blind channel identifications based on higher order cumulant fitting using genetic algorithms", in Proc. IEEE Signal Process. Workshop Higher Order Stat., pp 184-188, July 1997.
- [2] J.G. Proakis, Digital Communications, 4th ed, New York: McGraw-Hill, 2001.
- [3] A.H. Sayed, Fundamentals of Adaptive Filtering. Hoboken, NJ: Wiley, 2003.
- [4] S.A. Banani R.G. Vaughan, "Blind Channel estimation for in mobile OFDM system", IEEE Trans. Consum. Electron., vol. 44, no.3, pp. 1122-1128, Aug 1998.
- [5] M.X. Chang and T.D. Hsieh, "Detection of OFDM signals in fast varying channels with low density pilot symbols", IEEE Trans. Veh. Technol., vol. 57, no. 2, pp. 859-872, Mar 2008.
- [6] N. Chotikakamthorn and H. Suzuki, "On identifiability of OFDM blind channel estimation", in Proc. Veh. Technol. Conf., vol. 4, pp. 2358-2361, Sep 1999.
- [7] R. Negi and J. Cioffi, "Pilot tone selection for channel estimation in a mobile OFDM System", IEEE Trans. Consum. Electron., vol. 44, no. 3, pp. 1122-1128, Aug 1998.
- [8] B. Muquet, M. De Courville and P. Duhamel, "Subspace based blind and semiblind channel estimation for OFDM systems", IEEE Trans. Signal Process., vol. 50, no. 7, pp. 1699-1712, Jul 2002.
- [9] W. Chen and R. Zhang, "Kalman filter channel estimator for OFDM systems in time-frequency selective fading environment", in Prox. ICASSP, vol. 4, pp. 377-380, May 2004.
- [10] S. Thoen, L. Van der Perre, M. Engels and H. De Man, "Adaptive loading for OFDM/SDMA based wireless networks," IEEE Trans. Commun., vol. 50, no. 11, pp. 1798-1810, Nov 2002.
- [11] Zhengdao Wang, Member, IEEE, Xiaoli Ma, Member, IEEE, and Georgios B. Giannakis "OFDM or Single-carrier Block Transmission", IEEE Trans. Commun., vol. 52, no. 3, Mar. 2004.
- [12] Punchihewa, Vijay K. Bhargava and Charles Despins, "Blind Estimation of OFDM Parameters in Cognitive Radio Networks", IEEE Trans. Wireless Commun., vol. 10, no. 3, Mar 2011.