

Natural Convection from a Long Horizontal Cylinder

Hussein Awad Kurdi Saad

Engineering Technical College of Al –Najaf, Al-Furat Al-Awsat Technical University, Iraq

ABSTRACT: Natural convection from a Long Horizontal Cylinder with a diameter 10 meter will be solved in this problem. The surface has temperature $T_{\text{surface}}=100\text{ }^{\circ}\text{C}$ and the ambient temperature is $0\text{ }^{\circ}\text{C}$. As a result, this problem can be solved by using ANSYS (14.5)-CFD. Moreover, Grashof number Gr , Prandtl number Pr , and Rayleigh number Ra_L will be calculated. In addition, the contour of the temperature will be plotted. Furthermore, the vector diagram of the velocity will be plotted. Finally, Nusselt number Nu_L will be calculated and compared.

KEYWORDS: Natural Convection, Horizontal Cylinder, Nusselt Number.

I. INTRODUCTION

Free or natural convection is one of the most important methods of heat transfer that moves the heat from point to another due to fluid movement. The fluid motion is not created by any external force. It is occurred only due to density differences which happen in the fluid due to temperature variations.

In this paper, natural heat transfer convection from long horizontal cylinder has been investigated in this study more than five decades and lately the study has been concentrated on arrays and pairs cylinders [1]. Morgan, Churchill, and Chu, and other researchers have been calculated experimental correlation equations which concentrate actually on the field and time-averaged Nusselt number [1, 2].

Hassani demonstrated an anticipation for heat transfer natural convection from isothermal 2-dimensions from arbitrarily cross-sectional bodies [3]. Clemes et al. examined empirically free convection in air for many cases such as horizontal, comparatively long isothermal cylinders of variously cross-sectional areas for Rayleigh numbers between 103 and 109 [4].

Natural convection from a Long Horizontal Cylinder can be solved by using ANSYS 14.50-CFD with two dimensions (2D) to analyze the fluid flow. The dimensions of a rectangular around the cylinder are (130 m) length and 50 m width. The diameter of the cylinder inside the rectangular is 10 m. The surface temperature T_{surface} is $100\text{ }^{\circ}\text{C}$, and the ambient temperature is $0\text{ }^{\circ}\text{C}$.

Material properties are density ($\rho = 1\text{ kg/m}^3$), specific heat capacity ($C_p=1\text{ J/kg-k}$), and viscosity ($\mu = 1\text{ Pa-s}$). Also, acceleration due to Earth's gravity (g) is 10 m/s^2 , and the thermal conductivity (k) is $1.428571\text{ W/(m}\cdot\text{K)}$. Figure (1) indicates the dimensions of the Long Horizontal Cylinder inside the rectangular.

International Journal of Innovative Research in Science, Engineering and Technology

(An ISO 3297: 2007 Certified Organization)

Website: www.ijirset.com

Vol. 6, Issue 9, September 2017

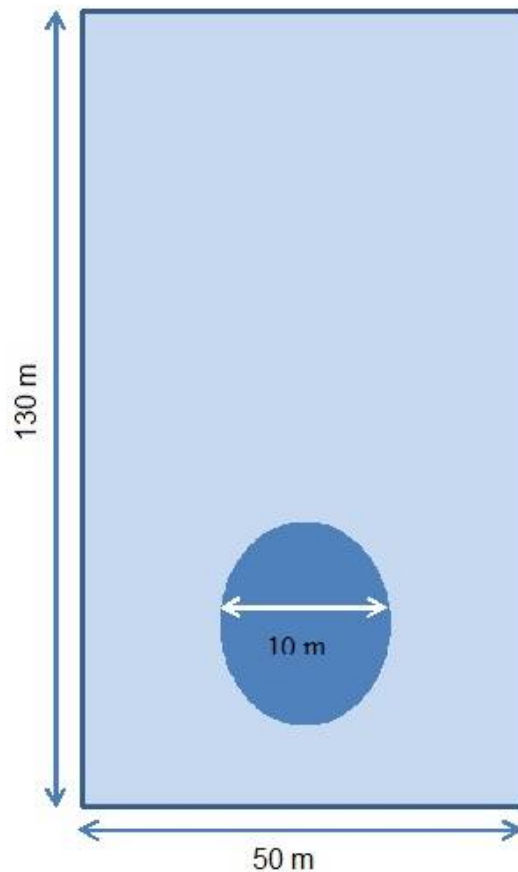

Fig. 1. The dimensions of the Long Horizontal Cylinder inside the rectangular

II. NUMERICAL SIMULATION

Pointwise is used to solve this problem. Circle is created in Pointwise with 10 m diameter. Then, the domain around the circle was created as a rectangle. The dimensions of the rectangle are 50 m width and 130 m length. The circle is located inside the rectangle. Also, from create, normal has been chosen from extrude. Then, from attributes, orientation is chosen and Flip is put with 40 steps. The nodes for the circle are 200 while the number of nodes is 50 for width and 200 for the length. Select solver is chosen from CAE to choose ANSYS Fluent. Finally, set dimension has chosen from CAE to select 2D (2-Dimensions). Figure (2) indicates the mesh in Pointwise.

International Journal of Innovative Research in Science, Engineering and Technology

(An ISO 3297: 2007 Certified Organization)

Website: www.ijirset.com

Vol. 6, Issue 9, September 2017

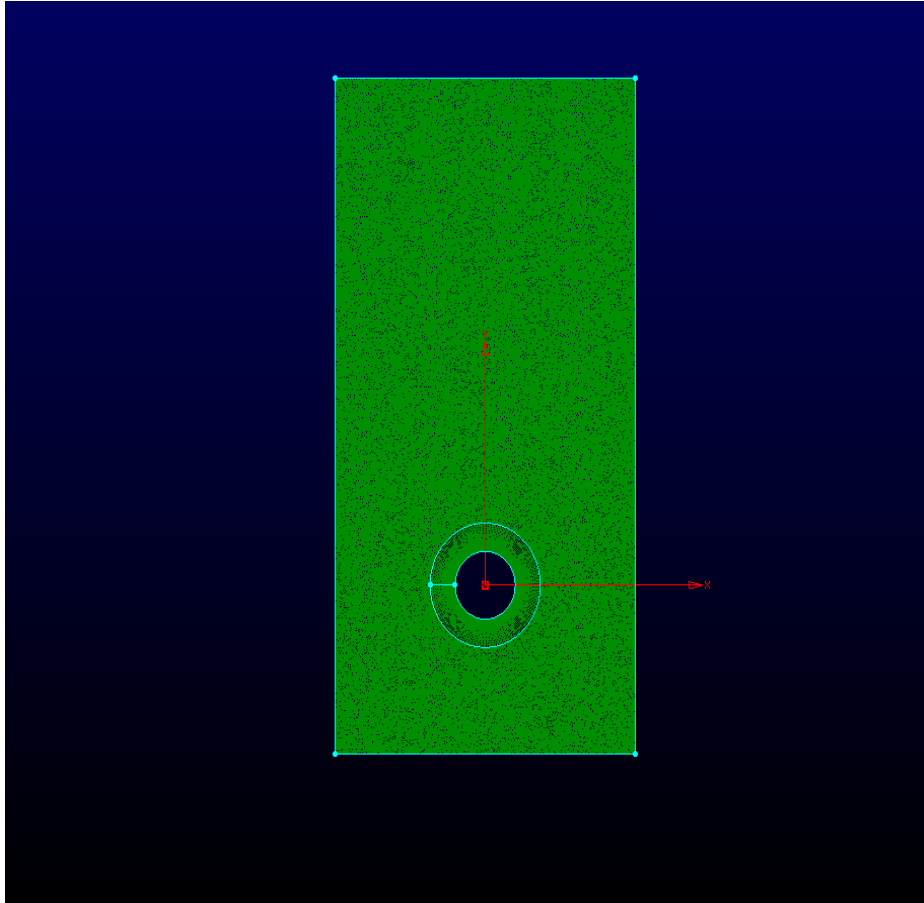

Fig. 2.Mesh in Pointwise

Furthermore, from CFX-Pre 14.5, the file can be imported. As soon as the new material is applied, creating new domain will be the next step. Also, the heat transfer model is changed to thermal energy and none for Turbulence. Moreover, create boundary conditions with opening, inlet, outlet, symmetry, and wall. In addition, Non-buoyant is changed to Buoyant with $g=10 \text{ m/s}^2$ acceleration due to Earth's gravity (g). The solver control criteria are chosen by changing the maximum number iteration in convergence control to 100000 and residual target in convergence control to 0.0000001. Figure (3) indicates the setup.

International Journal of Innovative Research in Science, Engineering and Technology

(An ISO 3297: 2007 Certified Organization)

Website: www.ijirset.com

Vol. 6, Issue 9, September 2017

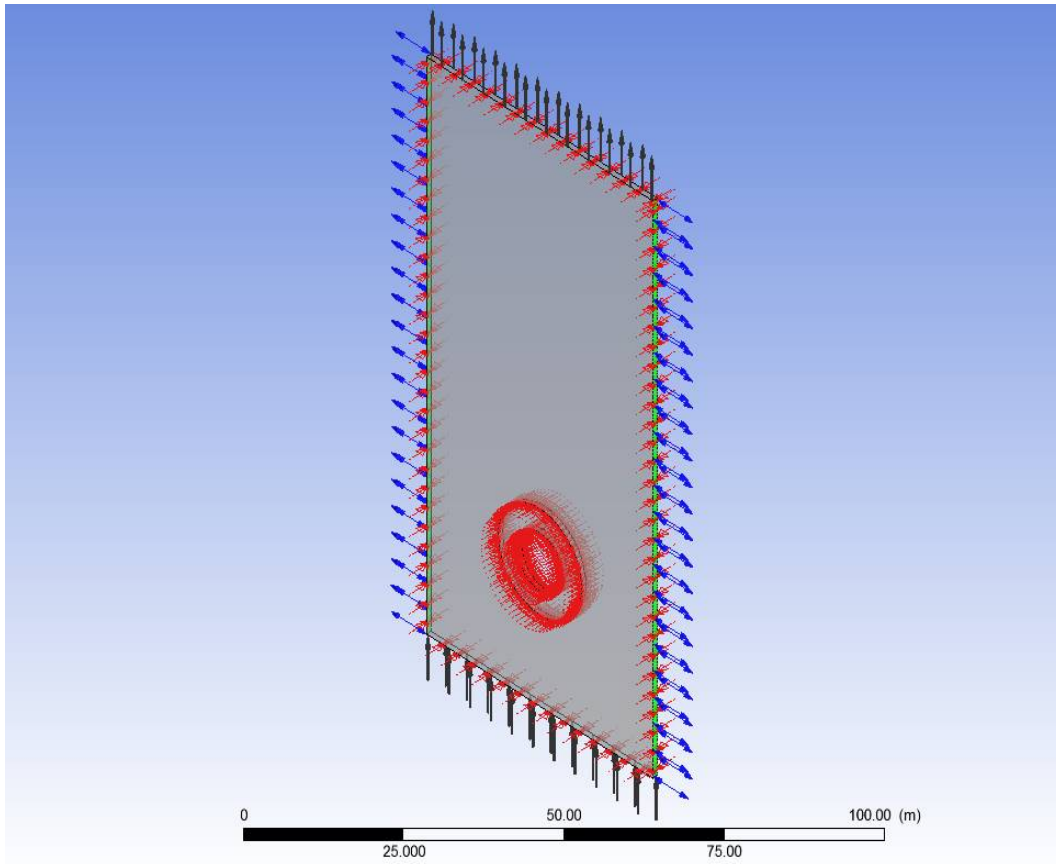

Fig. 3. The setup process

III. RESULTS

Grashof number Gr , Prandtl number Pr , and Rayleigh number Ra_L can be calculated from the following equations [5, 6]:

1- Grashof number's equation:

$$G_r = \frac{g \cdot \beta \cdot (T_s - T_\infty) \cdot D^3}{\left(\frac{\mu}{\rho}\right)^2} \quad (1)$$

$$G_r = \frac{10 \times 0.1 \times (100 - 0) \times 10^3}{\left(\frac{1}{1}\right)^2} = 10^5$$

2- Prandtl number's equation:

$$P_r = \frac{\mu \cdot c_p}{K} \quad (2)$$

International Journal of Innovative Research in Science, Engineering and Technology

(An ISO 3297: 2007 Certified Organization)

Website: www.ijirset.com

Vol. 6, Issue 9, September 2017

$$P_r = \frac{1 \times 1}{1.428571} = 0.7$$

3- Rayleigh number's equation:

$$Ra_D = G_r \cdot P_r \tag{3}$$

$$Ra_D = 10^5 \times 0.7 = 70000$$

After CFX-solver manager 14.50 is run, CFD-post 14.50 is used. In this stage, a contour diagram of the temperature can be plotted with 7000 iterations. Figure (4) shows the contour diagram of temperature with minimum temperature [276.1 k] to maximum temperature [373.1 k]. These results are found by applying $\beta = 0.1 \text{ k}^{-1}$.

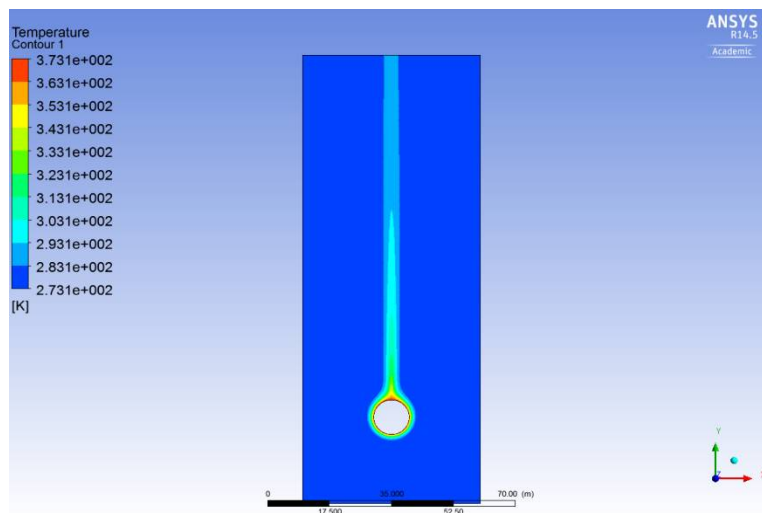

Fig. 4. The contour diagram of temperature with $\beta = 0.1 \text{ k}^{-1}$

In addition, the contour diagram of velocity can be plotted by changing the variable from temperature to velocity. Figure (5) indicates the contour diagram of the velocity with the minimum velocity 0 m/s to the maximum velocity 5.084 m/s.

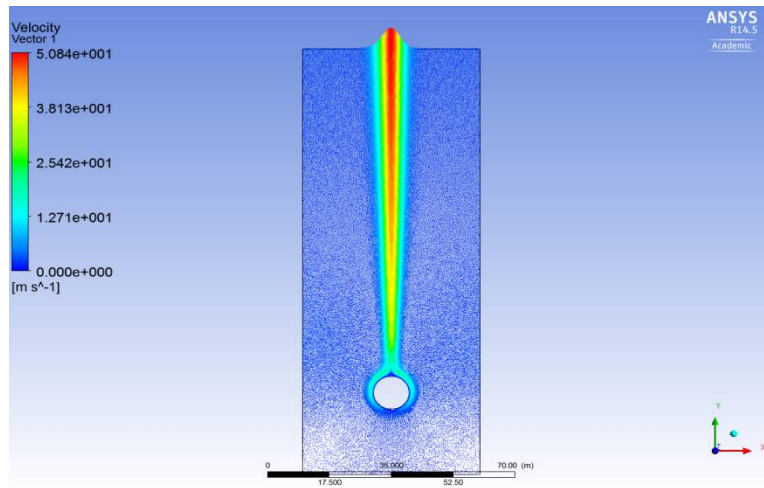

Fig. 5. The contour diagram of the velocity with $\beta=0.1 \text{ k}^{-1}$

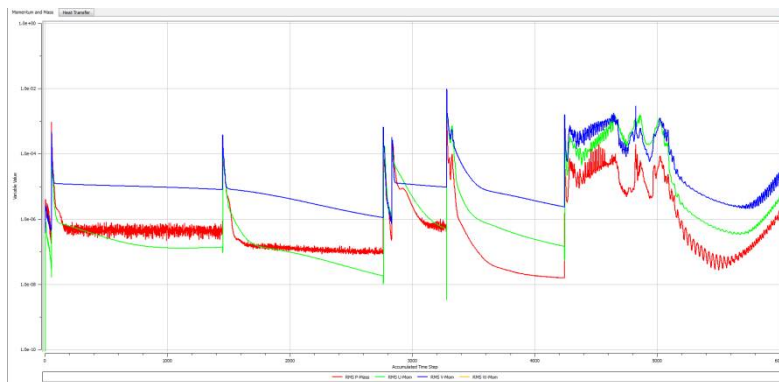

Fig. 6. Results for Momentum of mass with $\beta=0.1 \text{ k}^{-1}$

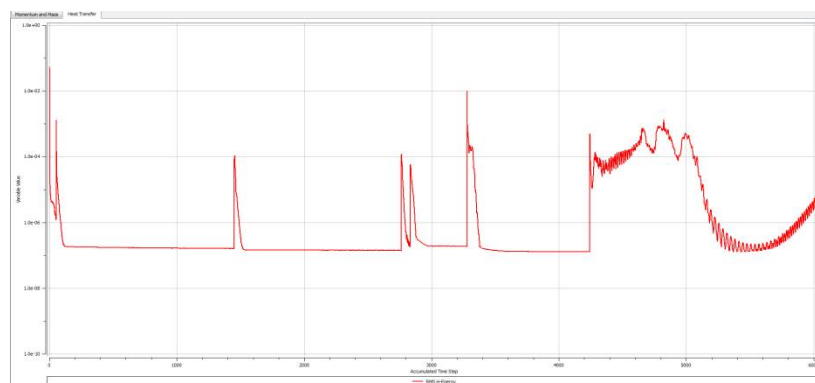

Fig. 7. Results for Heat Transfer with $\beta=0.1 \text{ k}^{-1}$

Figure (8) indicates the contour diagram of the velocity with wall heat flux $[103.879 \text{ W/m}^2]$

International Journal of Innovative Research in Science, Engineering and Technology

(An ISO 3297: 2007 Certified Organization)

Website: www.ijirset.com

Vol. 6, Issue 9, September 2017

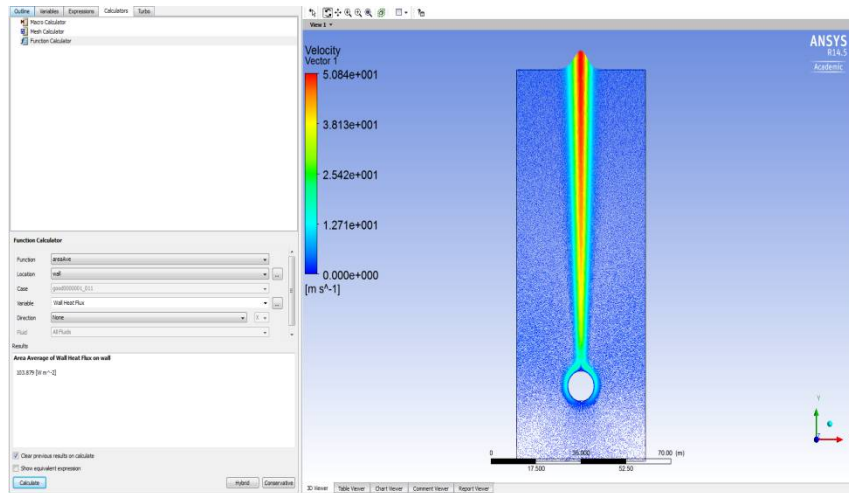

Fig. 8. The contour diagram of the velocity and Wall Heat Flux with $\beta=0.1 \text{ k}^{-1}$

Nusselt number can be calculated by two methods: the theoretical method and simulated method.

The theoretical method

From [6] Nusselt number can be calculated by:

$$Nu_u = \left[0.6 + \frac{0.387 \times Ra_D^{1/6}}{\left[1 + \left(\frac{0.559}{Pr} \right)^{9/16} \right]^{8/27}} \right]^2 \quad (4)$$

$$Nu_u = \left[0.6 + \frac{0.387 \times 70000^{1/6}}{\left[1 + \left(\frac{0.559}{0.7} \right)^{9/16} \right]^{8/27}} \right]^2 = 7.07684$$

According to heat transfer rate value from figure (9), the Nusselt number can be calculated from the equations below:
From the simulation

$$\begin{aligned} \frac{\dot{Q}}{A} &= 103.879 \\ \bar{h} &= \frac{103.879}{(100 - 0)} \\ \bar{h} &= 1.03879 \text{ W/m}^2 \cdot \text{k} \end{aligned}$$

Therefore,

$$\overline{Nu} = \frac{\bar{h}D}{k} = \frac{1.03879 * 10}{1.428571} = 7.2715$$

International Journal of Innovative Research in Science, Engineering and Technology

(An ISO 3297: 2007 Certified Organization)

Website: www.ijirset.com

Vol. 6, Issue 9, September 2017

As a result, the difference between the theoretical value and the value from the simulation is very small. It is about 0.19466. So, the results are correct.

$$\% \text{ Error} = \frac{7.07684 - 7.2715}{7.07684} * 100 \%$$

$$\% \text{ Error} = 2.75 \%$$

Moreover, the simulation was allowed to run for long time with $\beta=0.1 \text{ k}^{-1}$ to reach almost 18500 iterations, and the results and Nusselt number are shown in the next figures. After trying many times to modify thermal Expansivity. The best results have been gotten from the simulation with $\beta=0.1 \text{ k}^{-1}$. Figure (9) shows the contour diagram of temperature with minimum temperature [273.1 k] to maximum temperature [373.1 k]. These results are found by applying $\beta= 0.1 \text{ k}^{-1}$.

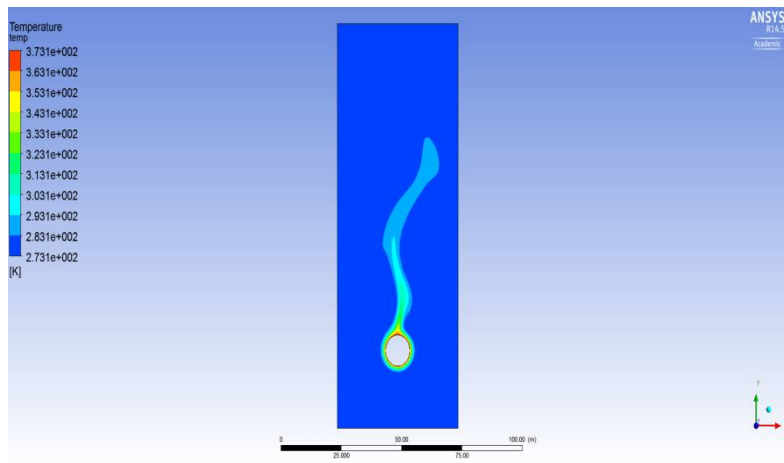

Fig. 9. The contour diagram of temperature with $\beta=0.1 \text{ k}^{-1}$

Moreover, the contour diagram of velocity can be plotted by changing the variable from temperature to velocity. Figure (10) indicates the contour diagram of the velocity with the minimum velocity 0 m/s to the maximum velocity 3.354 m/s.

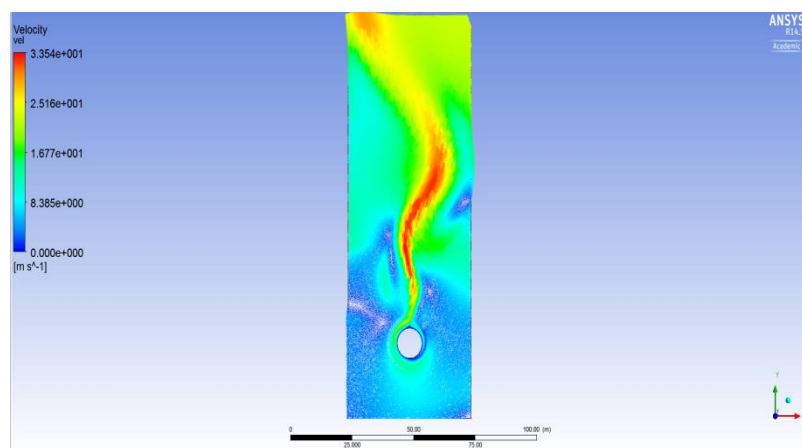

Fig. 10. the contour diagram of the velocity with $\beta=0.1 \text{ k}^{-1}$

International Journal of Innovative Research in Science, Engineering and Technology

(An ISO 3297: 2007 Certified Organization)

Website: www.ijirset.com

Vol. 6, Issue 9, September 2017

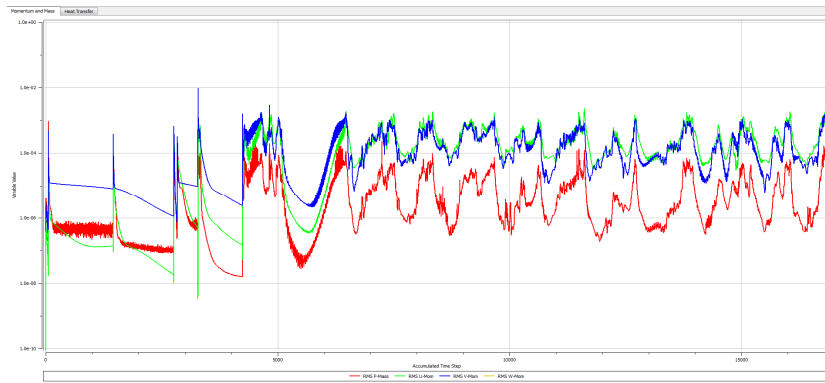

Fig. 11. Results for Momentum of mass with $\beta=0.1 \text{ k}^{-1}$

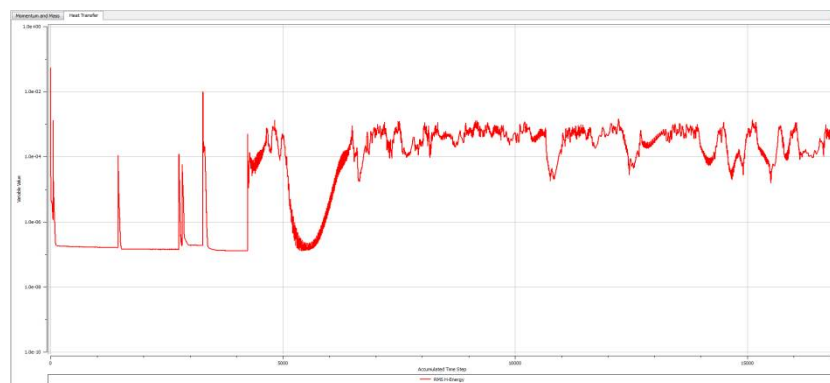

Fig. 12. Results for Heat Transfer with $\beta=0.1 \text{ k}^{-1}$

Figure (13) indicates the contour diagram of the velocity with wall heat flux [97.3859 W/m²]

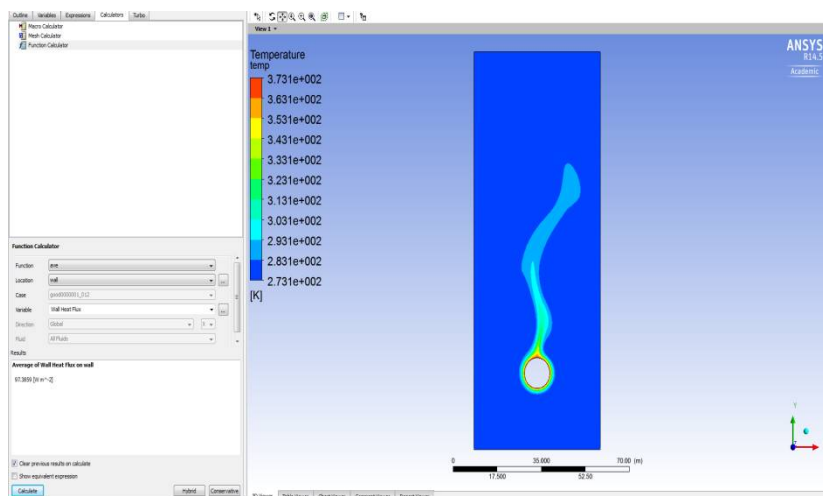

Fig. 13. The contour diagram of the velocity with Wall Heat Flux

International Journal of Innovative Research in Science, Engineering and Technology

(An ISO 3297: 2007 Certified Organization)

Website: www.ijirset.com

Vol. 6, Issue 9, September 2017

Nusselt number can be calculated by two methods:

1- The theoretical method

$Nu = 7.07684$ as calculated in equation (4)

2- The simulation method

$$\overline{Nu} = \frac{\bar{h}D}{k}$$

$$\dot{Q} = \bar{h} * A * (T_S - T_\infty)$$

$$\bar{h} = \frac{\dot{Q}}{A * (T_S - T_\infty)}$$

From the simulation

$$\frac{\dot{Q}}{A} = 97.3859$$

$$\bar{h} = \frac{97.3859}{(100 - 0)}$$

$$\bar{h} = 0.973859 \text{ W/m}^2 \cdot \text{k}$$

Therefore,

$$\overline{Nu} = \frac{\bar{h}D}{k} = \frac{0.973859 * 10}{1.428571} = 6.817015$$

As a result, the difference between the theoretical value and the value from the simulation is very small. It is about 0.2598 (7.07684 - 6.817015). So, the results are correct.

$$\% \text{ Error} = \frac{7.07684 - 6.817015}{7.07684} * 100 \%$$

$$\% \text{ Error} = 3.67\%$$

IV. CONCLUSION

Natural convection for a Long Horizontal Cylinder with a diameter 10 meter was solved in this problem by using ANSYS (14.5)-CFD. The contour diagram of temperature between [273.1 k] and [373.1 k] from the simulation with $\beta = 0.1 \text{ k}^{-1}$. and the contour diagram of the velocity range from 0 m/s to 3.354 m/s with $\beta = 0.1 \text{ k}^{-1}$. Moreover, Nusselt number is calculated with theoretical method, and it is found after 7000 iterations. The best stability of flow is found after 18500 iterations. The error percentage in case of (7000 iterations) is almost smaller to the case of (18500 iterations). For instance, the difference between the theoretical and simulation methods in Nusselt number for the case of (7000 iterations) is 0.19466, and the error percentage is 2.75 %. However, the difference in Nusselt number in case (18500 iterations) is 0.2598 with 18500 iterations, and also the error percentage of Nusselt number is 3.67 % in the second case. As a result, the difference between theoretical method and simulation method is so small in both cases. It is almost the same.

REFERENCES

- [1] Olivier Reymond, Darina B. Murray, Tadhg S. O'Donovan "Natural convection heat transfer from two horizontal cylinders" Journal of Experimental Thermal and Fluid Science 32 (2008) 1702-1709.
- [2] S.W. Churchill, H.H.S. Chu, Correlating equations for laminar and turbulent free convection from a horizontal cylinder, International Journal of Heat and Mass Transfer 18 (9) (1975) 1049-1053.

International Journal of Innovative Research in Science, Engineering and Technology

(An ISO 3297: 2007 Certified Organization)

Website: www.ijirset.com

Vol. 6, Issue 9, September 2017

- [3] A.V. Hassani, Natural convection heat transfer from cylinders of arbitrary cross section, ASME, J. Heat Transfer 114 (1992) 768–773.
- [4] S.B. Clemes, K.G.T. Hollands, A.P. Brunger, Natural convection heat transfer from long horizontal isothermal cylinders, Trans. ASME J. Heat Transfer 116 (1994) 96–104.
- [5] Chapter 2 "Natural Convection Heat Transfer From Horizontal Cylinders", <file:///C:/Users/original/Downloads/9783319081311-c2.pdf>
- [6] Frank P. Incropera, David P. DeWitt, Theodore L. Bergman, Adrienne S. Lavine, "Fundamental of Heat and Mass Transfer, Free Convection", Sixth Edition, pp. 559-597.