

Doubly Fed Induction Machine-Based Wind Generator Transient Stability Improvement Using Bridge-Type Fault Current Limiter

Kamsali.Mounika¹, S.Imran Khan², D.Mahesh Kumar³M.Tech Student, Dept of EEE, Ananthalakshmi Institute of Technology and Sciences, AP, India ¹Assistant Professor, Dept. of EEE Ananthalakshmi Institute of Technology and Sciences, AP, India²Associate Professor & HOD, Dept. of EEE, Ananthalakshmi Institute of Technology and Sciences, AP, India ³

ABSTRACT: In this paper Transient stability is a major sympathy toward doubly fed induction machine (DFIM). A DFIM-based wind generator is promptly influenced by shortcomings at the network side as its stator windings are interfaced to grid. Be that as it may, the wind generators need to stay connected and proceed with operation during flaws at the grid side as indicated by the network code prerequisites. Along these lines, it is imperative to improve the transient soundness of the DFIM-based wind generators. To accomplish upgraded transient steadiness of the DFIM, a bridge type fault current limiter (BFCL) is proposed in this study.

KEYWORDS: BFCL, Doubly Fed Induction Machine (DFIM), Rotor-Side Converter (RSC) and Grid Side Converter (GSC)..

I. INTRODUCTION

Technological advancement and industrialization has brought the expansion up in electrical power demand all around the globe. Quick fatigue and restricted store of fossil powers, escalation of natural concerns have made it dire to look for alternative energy sources and to devise enhanced techniques for abusing renewable energy sources. Among the available renewable energy sources, wind energy is the quickest developing and most noticeable choice to create electric power because of its zero fuel cost, no carbon discharge, lower maintenance, and cleaner, less expensive and renewable nature. It is assessed that around 10% of worldwide power interest will be supplied from the wind energy by the year 2020. Because of adaptability in operation and upgraded highlights like higher output power, higher proficiency, enhanced power quality, variable pace operation, lower mechanical weight on turbine subsequently bring down support, decoupled control of the active and reactive power, the variable rate wind generators are getting to be favored decision for new establishments and drawing higher consideration than the conventional impelling machine-based altered rate wind generators. Lower cost, sturdiness, basic structure, probability to cover an extensive variety of wind rate, in part evaluated variable frequency ac/dc/air conditioning converter and lower switching loss have made the doubly sustained incitement machine (DFIM) a better decision over the other wind generator choices.

Contrasted with variable pace wind generators having full appraised converter, the DFIM is more powerless against grid shortcoming or unsettling influences from the soundness point of view, as its stator windings are straight forwardly associated with system while rotor windings are interfaced to grid by means of the rotor-side converter (RSC) and the grid side converter (GSC) that are connected consecutive through a dc-link capacitor. At the occasion of system deficiency, terminal voltage of the DFIM goes low and high current moves through both stator and rotor winding. This is a danger to stable operation and may inevitably blaze the machine and the converters. Customarily, to shield from such blame occurrences, wind generators were detached from the grid. The converter of the DFIM topology has the control capacity to keep up solidness at flaw condition. Since the converters have fractional rating, their ability alone is deficient to guarantee dependability. A helper gadget like static synchronous compensator is proposed yet it needs extra converter, coupling transformer and symphonious

International Journal of Innovative Research in Science, Engineering and Technology

(An ISO 3297: 2007 Certified Organization)

Website: www.ijirset.com

Vol. 6, Issue 9, September 2017

channels. Energy stockpiling systems like flywheel energy stockpiling, superconducting attractive energy stockpiling and superconducting deficiency current limiter are additionally proposed, however the high establishment cost counterbalances their great execution.

The bridge type fault current limiter (BFCL) is another method with promising applications in power systems and issue ride through ability improvement of altered speed wind turbine generators. Be that as it may, the BFCL is never connected to improve the transient solidness of DFIM-based wind generators. In this study, execution of the BFCL on upgrading the transient stability of the DFIM in wind energy application is researched. The effectiveness of the proposed BFCL is shown through a test wind energy conversion system. The system comprises of a wind turbine furnished with a DFIM, a transformer and the double circuit transmission lines connected with the boundless bus. Transitory symmetrical and unsymmetrical shortcomings were connected at the most powerless purpose of the system. Where ω_r is the angular mechanical speed. The wind turbine

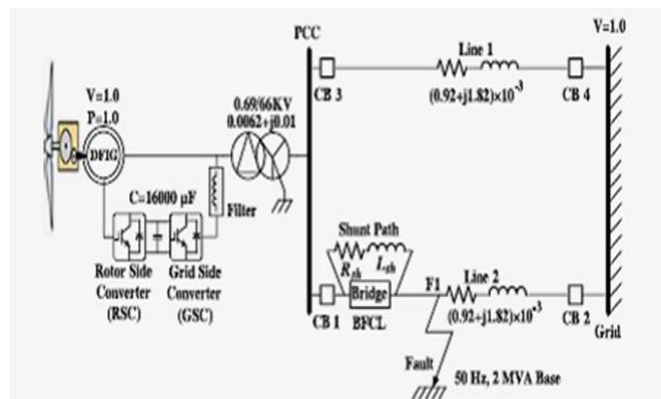

Fig: 1 Basic diagram of the DFIM with the test system.

II. WIND TURBINE AND DFIM MODELING

A solitary mass system is considered for the demonstrating of the wind turbine. The turbine mechanical part progression is dismissed because of little span of the considered deficiencies. The DFIM itself is fundamentally an actuation generator with the stator windings directly connected with grid and open rotor windings connected with the grid through the ac/dc/ac converter as appeared in Fig. 1. Fig. 1 likewise demonstrates the one line graph of the test system model alongside the line parameters. A 2-MW DFIM is connected with the point of common coupling (PCC) through a phase up transformer. The PCC is connected with network through double circuit transmission line. The BFCL is connected in series with one of the transmission lines to secure it as appeared in Fig. 1. The SDBR is likewise connected at the same point in comparative style. Displaying of the wind turbine, the DFIM and the converter controllers are outlined in the consequent segments.

A. Wind Turbine Modeling

The displaying of the wind turbine relies on upon different physical and geometrical angles. For effortlessness, considering the electrical conduct of the system just, a streamlined strategy for displaying the wind turbine is typically utilized. The normally utilized scientific connection for the mechanical power tackled from the wind, can be communicated as takes after

$$P_w = \frac{1}{2} \pi \rho R^2 V_w^3 C_p(\lambda, \beta) \quad \text{--- (1)}$$

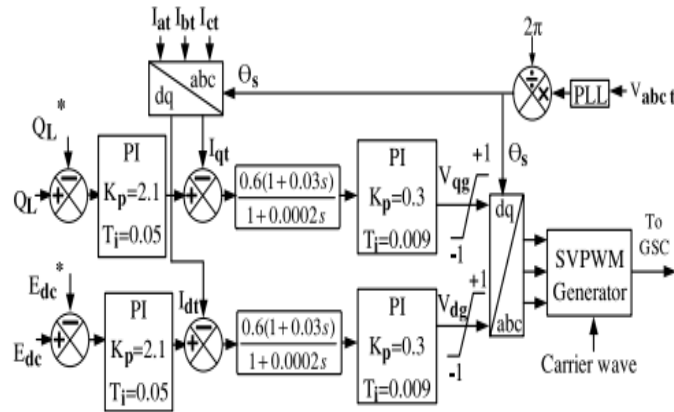

Fig. 3. GSC controller.

reference signal for space vector pulse width modulation (SVPWM) signal generator block, so that it can generate pulses for the IGBT switches of the RSC [27]. The Park's transformation is used to convert three phase quantities into equivalent d-q components and vice versa. The slip angle is generated by comparing the rotor position and the terminal voltage angle with the help of the phase-locked loop (PLL), and the slip is used as transformation angle in the Park's transformation block. Quantities with "*" refer to reference value as shown in Fig. 2.

D. GSC Controller

The GSC also contains a two-level, six-pulse, IGBT [CM200HG-130H] based full bridge power electronic ac/dc converter with the dc side connected to the dc link and the ac side interfaced to the grid. This converter essentially helps maintain a constant power factor at the connection point. It is important to choose an appropriate switching frequency to keep the harmonics to the minimum level. A frequency of 1650 Hz is chosen as it is an odd multiple of the third harmonic and can minimize up to thirteenth harmonics. The GSC controller scheme is given in Fig. 3. It takes the dc link voltage E_{dc} and the rotor line reactive power Q_L as inputs and produces the necessary outputs so that the SVPWM pulse generator can generate required pulses for the GSC converter. Also, by maintaining a constant dc-link voltage, the controller ensures the energy balance on the both sides of the dc link.

III. BFCL

BFCL Configuration

The BFCL is composed of two sections, namely the bridge part and the shunt path. The first part is essentially the bridge part composed of a few diodes D1-D4 [Semikron SKNa 402], a small-valued dc reactor L_{dc} equipped with a parallel free-wheeling diode D5 placed in series with an IGBT [CM200HG-130H] switch arranged as shown in Fig. 4. The IGBT switches normally come in a package with free-wheeling diode which is not shown here. Also, to include the inherited resistance of the inductor, a very small value resistor R_{dc} is considered. The second part is a shunt path composed of a resistor R_{sh} and an inductor L_{sh} placed in parallel to the bridge part as in Fig. 4.

International Journal of Innovative Research in Science, Engineering and Technology

(An ISO 3297: 2007 Certified Organization)

Website: www.ijirset.com

Vol. 6, Issue 9, September 2017

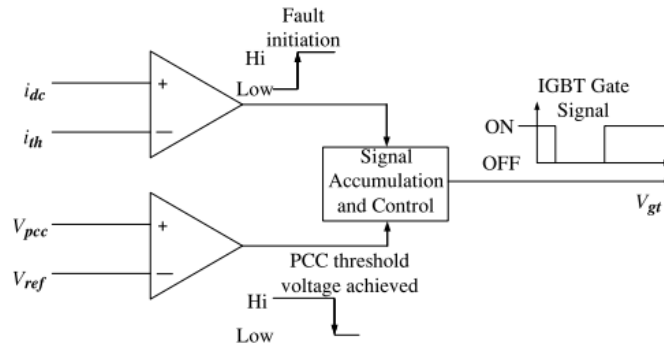

Fig. 5. BFCL controller

BFCL Operation

During normal operating condition of the system, the IGBT switch in the bridge part remains closed. For one half cycle of electrical frequency, the D1-Ldc-Rdc-D4 path carries the line current and for the other half it is carried by D2-Ldc-Rdc-D3.

So, the current through Ldc, flows in the same direction and this current is the dc current i_{dc} . Ldc is charged to the peak current and offers no impedance to i_{dc} . The dc reactor inherited resistance, the IGBT turn-on resistance and the diode forward voltage drop cause some voltage drop, but this voltage drop is quite negligible compared to line drop and has ignorable significance. So the bridge has no impact on normal or steady state operation.

IV. SDBR

In this study, so as to exhibit the effectiveness of the proposed BFCL arrangement, its execution is contrasted and that of the SDBR as shown in Fig.6. The SDBR is a demonstrated innovation, and past studies demonstrated that it can upgrade transient strength and enhance issue ride through ability of the wind generator systems.

SDBR Configuration

The SDBR is modeled by arranging a resistor with a parallel switch as shown in Fig. 6. This study considers this switch to be the IGBT based, due to its fast response and modular design.

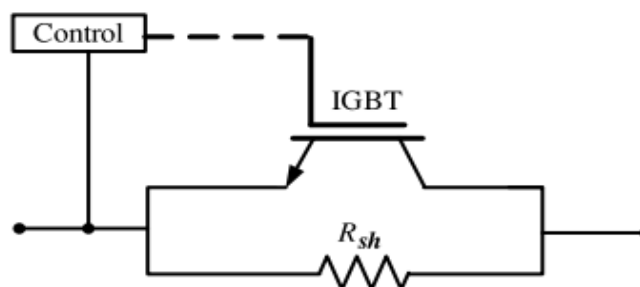

Fig. 6. Single phase SDBR topology

International Journal of Innovative Research in Science, Engineering and Technology

(An ISO 3297: 2007 Certified Organization)

Website: www.ijirset.com

Vol. 6, Issue 9, September 2017

B. SDBR Operation

During the normal condition, the SDBR would operate with the IGBT switch closed. The line current will flow through the IGBT switches bypassing the braking resistors. At the event of fault, the line currents tend to rise very sharply. The shunt resistor will be dynamically inserted into the network by opening the IGBT switch. The fault current will then flow through the inserted resistor and the resistor will continue to be in the circuit until a desired voltage V_{ref} is achieved at PCC. As V_{pcc} passes V_{ref} , the IGBT will be closed and the circuit will return to its normal state.

D. BFCL 1LG

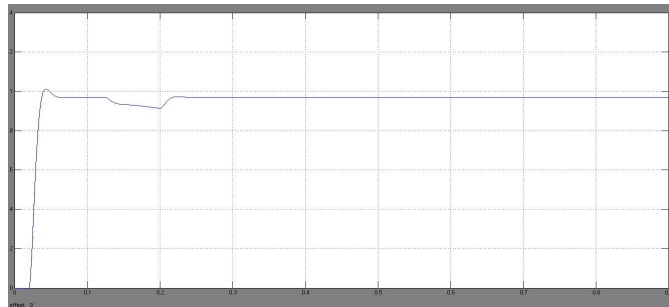

Fig 1: Terminal voltage response for 1LG Fault

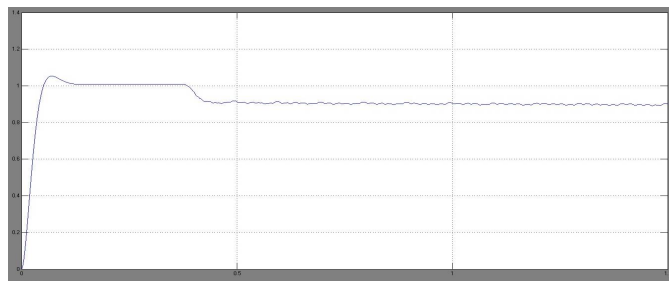

Fig 2: Machine output active power

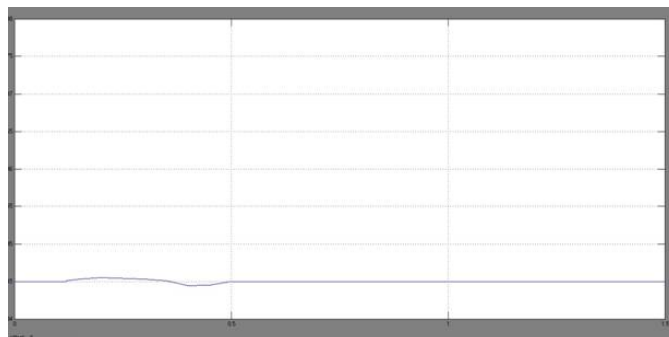

Fig 3:DC link voltage response for 1LG Fault.

International Journal of Innovative Research in Science, Engineering and Technology

(An ISO 3297: 2007 Certified Organization)

Website: www.ijirset.com

Vol. 6, Issue 9, September 2017

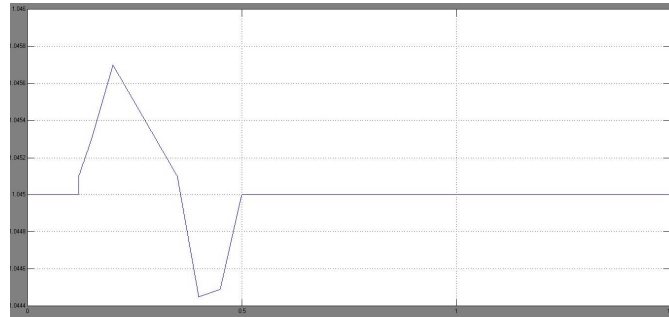

Fig 5: speed response for single LG Fault

E. BFCL 3LG:

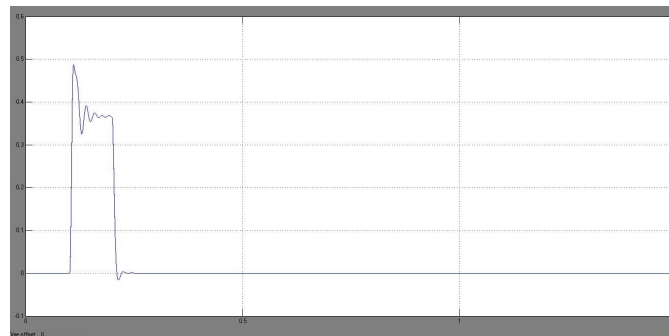

Fig 6 :Active power consumed in BFCL for 3LG Fault

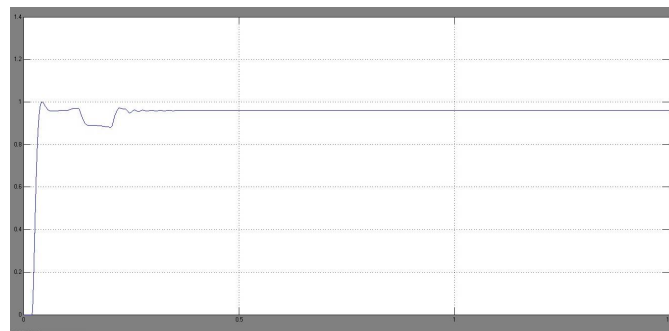

Fig 7: Machine output response for 3LG Fault

International Journal of Innovative Research in Science, Engineering and Technology

(An ISO 3297: 2007 Certified Organization)

Website: www.ijirset.com

Vol. 6, Issue 9, September 2017

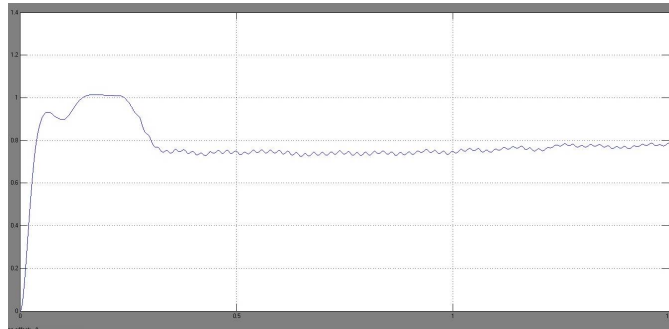

Fig 8: DC link voltage response for 3LG fault

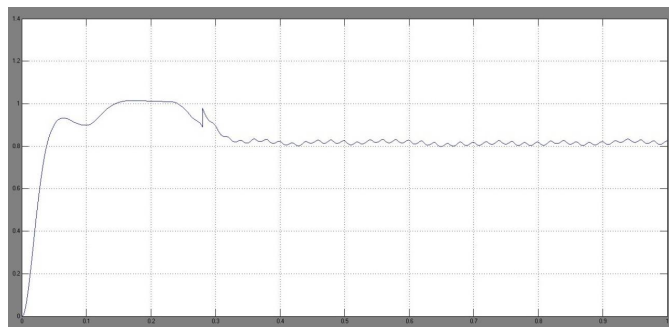

Fig 9: speed response for 3LG Fault

F. BFCL FOR 3LG USING FUZZY

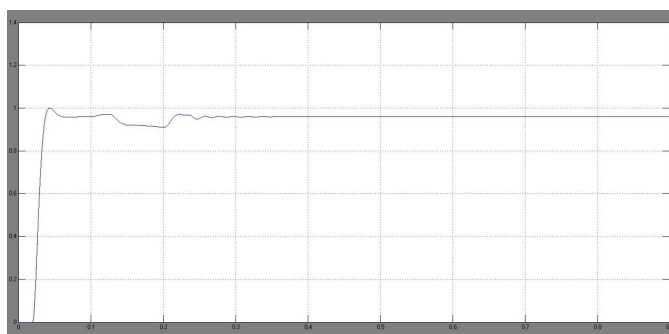

Fig 10: Active power response for 3 LG Fault using fuzzy

International Journal of Innovative Research in Science, Engineering and Technology

(An ISO 3297: 2007 Certified Organization)

Website: www.ijirset.com

Vol. 6, Issue 9, September 2017

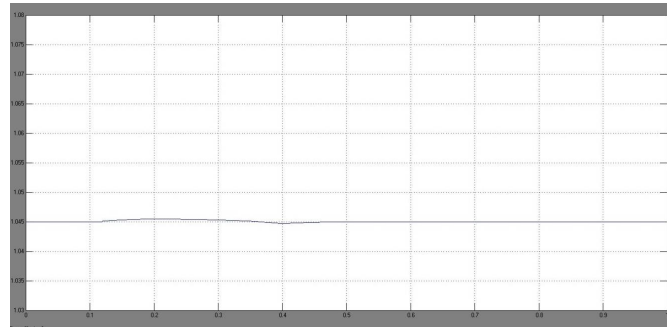

Fig 11: Terminal voltage response for 3LG Fault using fuzzy

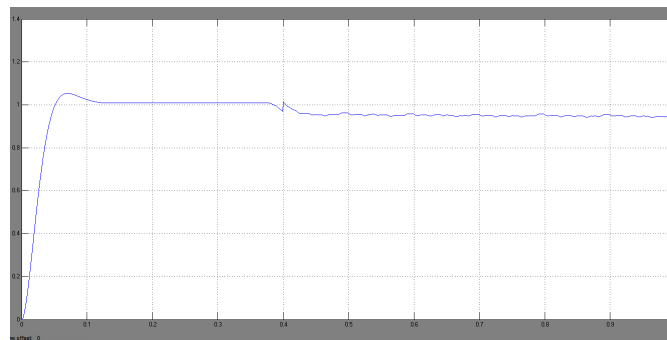

Fig 12: DC Link voltage response for 3LG Fault using fuzzy



Fig 13: speed response for 3LG Fault using fuzzy

VII. CONCLUSION

The application of the BFCL to enhance the transient stability of DFIM is proposed in this paper. The performance of the proposed BFCL is compared with that of the SDBR. From the simulation results, the following points are noteworthy.

- 1) The BFCL is a very effective means to enhance the transient stability of the DFIM-based variable speed wind generator.
- 2) The BFCL can help the DFIM-based wind farms abide by the grid code requirements.
- 3) The SDBR is outperformed by the BFCL in every aspect,

International Journal of Innovative Research in Science, Engineering and Technology

(An ISO 3297: 2007 Certified Organization)

Website: www.ijirset.com

Vol. 6, Issue 9, September 2017

except cost, as seen from graphical and numerical results. In our future study, a high capacity variable speed wind farm connected to a large power system will be considered. Also, a prototype of the BFCL will be tested with low voltage and little power test bench to check the effectiveness. Furthermore, an optimal design of the BFCL will be developed considering variable values of the shunt impedance.

REFERENCES

- [1] B. Singh, P. Jayaprakash, T. R. Somayajulu, and D. P. Kothari, "Reduced rating VSC with a zig-zag transformer for current compensation in a three-phase four-wire distribution system," *IEEE Trans. Power Del.*, vol. 24, no. 1, pp. 249–259, Jan. 2009.
- [2] R. M. Ciric, L. F. Ochoa, A. Padilla-Feltrin, and H. Nouri, "Fault analysis in four-wire distribution networks," *Proc. Inst. Elect. Eng., Gen., Transm. Distrib.*, vol. 152, no. 6, pp. 977–982, 2005.
- [3] J. C. Meza and A. H. Samra, "Zero-sequence harmonics current minimization using zero-blocking reactor and zig-zag transformer," in *Proc. IEEE DRPT*, 2008, pp. 1758–1764.
- [4] H. L. Jou, J. C. Wu, K. D. Wu, W. J. Chiang, and Y. H. Chen, "Analysis of zig-zag transformer applying in the three-phase four-wire distribution power system," *IEEE Trans. Power Del.*, vol. 20, no. 2, pt. 1, pp. 1168–1178, Apr. 2005.
- [5] S. Choi and M. Jang, "Analysis and control of a single-phase inverter zig-zag transformer hybrid neutral-current suppressor in three-phase four-wire systems," *IEEE Trans. Ind. Electron.*, vol. 54, no. 4, pp. 2201–2208, Aug. 2007.
- [6] F. Mei and B. C. Pal, "Modelling of doubly-fed induction generator for power system stability study," in *Proc. IEEE Power Energy Soc. Gen. Meeting*, Jul. 2008, pp. 1–8.
- [7] G. D. Marques, "Active stabilization method for the doubly-fed induction generator using a quadrature inner control loop," in *Proc. Int. Conf. Power Eng. Energy Elect. Drives*, Apr. 2007, pp. 765–768.
- [8] G. D. Marques, "Comparison of active stabilization methods for the doubly-fed induction generator—Quadrature versus direct inner control loops," in *Proc. Eur. Conf. Power Electron. Appl.*, Sep. 2007, pp. 1–10.
- [9] P. La Seta and P. Schegner, "Comparison of stabilizing methods for doubly fed induction generators for wind turbines," in *Proc. Int. Conf. Futur.*
- [10] *Power Syst.*, Nov. 2005, Paper W045, Conference CDROM. P. La Seta and P. Schegner, "New control scheme for doubly-fed induction generators to improve transient stability," in *Proc. IEEE Power Eng. Soc. Gen. Meeting*, Jun. 2007, pp. 1–10.
- [11] F. K. A. Lima, A. Luna, P. Rodriguez, E. H. Watanabe, and F. Blaabjerg, "Rotor voltage dynamics in the doubly fed induction generator during grid faults," *IEEE Trans. Power Electron.*, vol. 25, no. 1, pp. 118–130, Jan. 2010.
- [12] J. P. A. Vieira, M. V. A. Nunes, and U. H. Bezerra, "Improving the transient performance of doubly fed induction generators when submitted."

BIOGRAPHY

1. S. Imran Khan working as Assistant Professor in Anantha Lakshmi Institute of Technology and sciences Anantapur, Andhra Pradesh. He completed his M.Tech in 2014. He is interested in electrical Power systems and electrical machines domains.
2. Kamsali Mounika completed B.Tech. in SRIT in 2015. Now she is pursuing M.Tech. in ALTS. She is interested in power systems domain.
3. D. Mahesh Kumar working as Associate professor in Ananthalakshmi Institute of technology and sciences Anantapur Andhra Pradesh. He had experience of 4 years and his interested topics are power systems and power electronics.