

Modeling, Simulation and Speed Control of PMSM Motor by using MATLAB/Simulink

Rana Vrajesh¹, Khan Sahal², Ashish Singh Rajawat³, Rakholiya Tirth⁴, Shah Dhrumil⁵

U.G. Student, Department of Electrical Engineering, SRICT, Vataria, Gujarat, India¹²³⁴⁵

ABSTRACT: This paper presents, the mathematical model of a field oriented controlled Permanent Magnet motor drive system which is developed & simulated in MATLAB-Simulink. Today in many industries (especially in machine tool industry) the use of Permanent Magnet Synchronous Motor (PMSM) is increasing due to smaller size, less weight & low rotor loss compare to induction motor of same capacity. One of the important characteristics of Permanent Magnet Synchronous Motor is that they produce constant torque with sinusoidal stator current. The simulation model includes all the required component of the drive system. Due to this the calculation of current and voltages in different parts of the inverter and motor under transient and steady conditions are possible. A closed loop control system in the speed loop has been designed to operate in constant torque and flux weakening regions. The principle of speed control is verified by analyzing the variation in the results of speed & torque.

KEYWORDS: Text detection, Inpainting, Morphological operations, Connected component labelling.

I. INTRODUCTION

Many types of electric motors have been used in the industry for different purposes: cranes, spinning machines, public transportation. AC motors are widely used and ac drives are subject of study for many researchers. Recently, ac drives in vehicle applications are gaining attention due to pollution and fuel price problems.

In the electrical system of an electric or hybrid electric vehicle based on an ac motor, the motor is producing torque from the battery through the inverter. To charge the battery the grid power is utilized in some vehicles called grid-connected version. Since the battery charging and traction power is not happening simultaneously it is possible to use inverter and motor in charger circuit to reduce the price, volume, weight and space of the charger. This is called integrated charger.

An isolated high-power integrated charger is proposed in that is based on a special ac motor winding configuration. To implement a practical system of the proposed integrated charger, this current subproject is defined to be extended later on. Many types of electric motors have been used in the industry for different purposes: cranes, spinning machines, public transportation. AC motors are widely used and ac drives are subject of study for many researchers. Recently, ac drives in vehicle applications are gaining attention due to pollution and fuel price problems.

In the electrical system of an electric or hybrid electric vehicle based on an ac motor, the motor is producing torque from the battery through the inverter. To charge the battery the grid power is utilized in some vehicles called grid-connected version. Since the battery charging and traction power is not happening simultaneously it is possible to use inverter and motor in charger circuit to reduce the price, volume, weight and space of the charger. This is called integrated charger.

An isolated high-power integrated charger is proposed in that is based on a special ac motor winding configuration. To implement a practical system of the proposed integrated charger, this current subproject is defined to be extended later on.

International Journal of Innovative Research in Science, Engineering and Technology

(A High Impact Factor, Monthly, Peer Reviewed Journal)

Visit: www.ijirset.com

Vol. 7, Issue 12, December 2018

II. WORKING PRINCIPAL

The working principle of permanent magnet synchronous motor is same as that of synchronous motor. When three phase winding of stator is energized from 3 phase supply, rotating magnetic field is set up in the air gap. At synchronous speed, the rotor field poles locks with the rotating magnetic field to produce torque and hence rotor continues to rotate.

As we know that synchronous motors are not self-starting, PMSM needs to be started somehow. Since there is no winding on the rotor, induction windings for starting is not applicable for such motors and therefore variable frequency power supply for this purpose.

III. BLOCK DIAGRAM

The motor drive consists of four main components, the PM motor, inverter, control unit and the position sensor. The components are connected as shown in Figure 1.

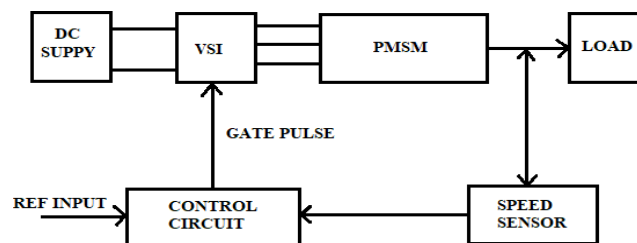

Fig 1;- Block Diagram of PMSM Motor

The main components of the system are:

1. Permanent Magnet Synchronous Motor
2. Various Position Sensors

Optical Encoders

Optical encoder is very popular type of encoder in industry. This consists of a rotating disk, a light source, and a photo detector. The disk, is mounted on the rotating shaft, has coded patterns of opaque and transparent sectors. As the disk rotates, these patterns interrupt the light emitted onto the photo detector, generating a digital pulse or output signal.

Incremental encoders

Incremental encoders have good precision and are simple to implement but they suffer from lack of information when the motor is at rest position and in order for precise position the motor must be stop at the starting point.

Absolute encoders

The absolute encoder exact position of the rotor with a precision directly related to the number of bits of the encoder. It can rotate indefinitely and even if the motor stops, the position can be measured or obtained.

International Journal of Innovative Research in Science, Engineering and Technology

(A High Impact Factor, Monthly, Peer Reviewed Journal)

Visit: www.ijirset.com

Vol. 7, Issue 12, December 2018

Position Revolver

Position revolver is also known as rotary transformers. It works on the transformer principle in which the primary winding is placed on the rotor. Depending upon the rotor shaft angle the induced voltage at the two secondary windings of the transformer is shifted by 90° . The position can be calculated using two voltages.

Inverter

Voltage Source Inverters are devices that convert a DC voltage to AC voltage of variable frequency and magnitude. They are very commonly used in adjustable speed drives and are characterized by a well-defined switched voltage wave form in the terminals.

Controller

The controller will generate the reference currents with the inverter within a range which is fixed by the width of the band gap. In this controller the desired current of a given phase is summed with the negative of the measured current. The error is fed to a comparator having a hysteresis band. When the error crosses the lower limit of the hysteresis band, the upper switch of the inverter leg is turned on. But when the current attempts to become less than the upper reference band, the bottom switch is turned on.

Load

For inverter power electronics switches are used. The switch is selected on the basis of its power capability and switching current.

IV. APPLICATION

- PMSM can be used an alternative for servodrives.
- Widely used in various industrial application
- Robotics
- Traction
- Aerospace

V. SIMULATION OF MOTOR

1. PMSM Motor

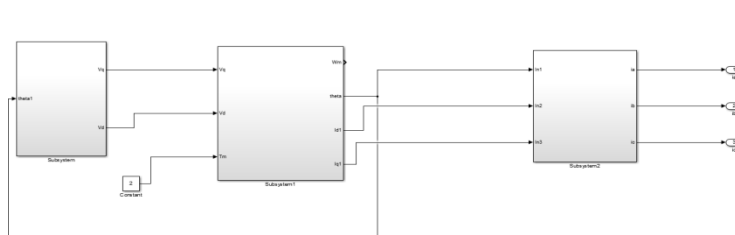

Motor Parameter:

$L_d = 0.0066$
 $Y_{af} = 0.1546$
 $L_q = 0.0058$

International Journal of Innovative Research in Science, Engineering and Technology

(A High Impact Factor, Monthly, Peer Reviewed Journal)

Visit: www.ijirset.com

Vol. 7, Issue 12, December 2018

- R_a = 1.4
- R_d = 1.4
- P = 6
- J_{sb} = 0.00176
- B = 0.00038818

2. Vabc to Vdq Transformation

$$V_d = \frac{2}{3} * \left\{ V_a \cos(\theta) + V_b \cos\left(\theta - \frac{2\pi}{3}\right) + V_c \cos\left(\theta + \frac{2\pi}{3}\right) \right\}$$

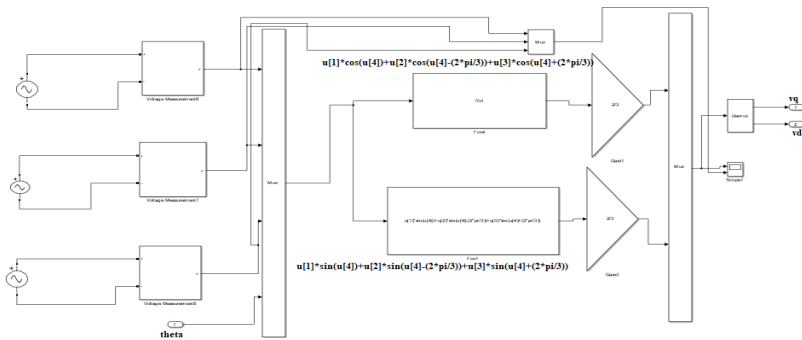

$$V_q = \frac{2}{3} * \left\{ V_a \sin(\theta) + V_b \sin\left(\theta - \frac{2\pi}{3}\right) + V_c \sin\left(\theta + \frac{2\pi}{3}\right) \right\}$$

3. Id Calculation

$$i_d = \frac{1}{L_d} \left[\int [V_d - (R_d * i_d) + (i_q * \omega_e * L_q)] \right]$$

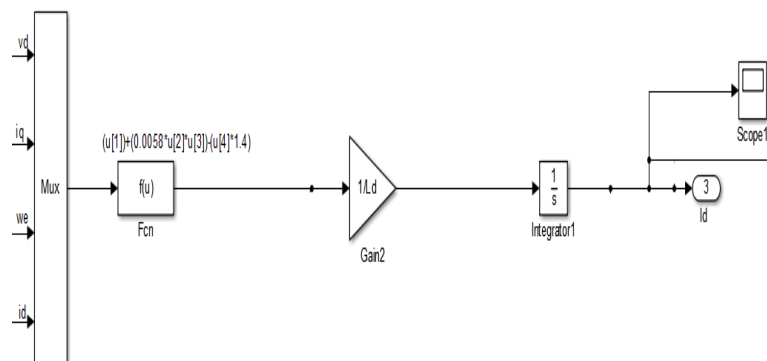

International Journal of Innovative Research in Science, Engineering and Technology

(A High Impact Factor, Monthly, Peer Reviewed Journal)

Visit: www.ijirset.com

Vol. 7, Issue 12, December 2018

4. Iq Calculation

$$i_q = \frac{1}{L_q} \int [v^d - l_d * (i_d * \omega_e) + (\omega_e * Yaf) - (i_q * R_a)]$$

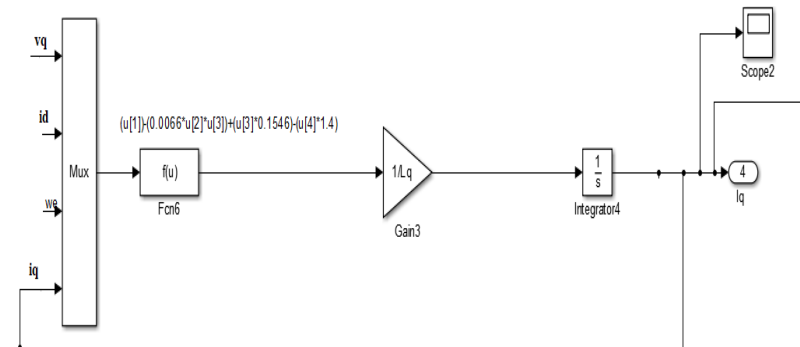

5. Theta & We Calculation

$$\omega_e = (T_m - T_e) + \left(\frac{1}{(JS + B)}\right) * \left(\frac{P}{2}\right)$$

$$\theta = P * \left(\frac{3}{4}\right) [Yaf * i_q + i_d * i_q * (L_d - L_q)]$$

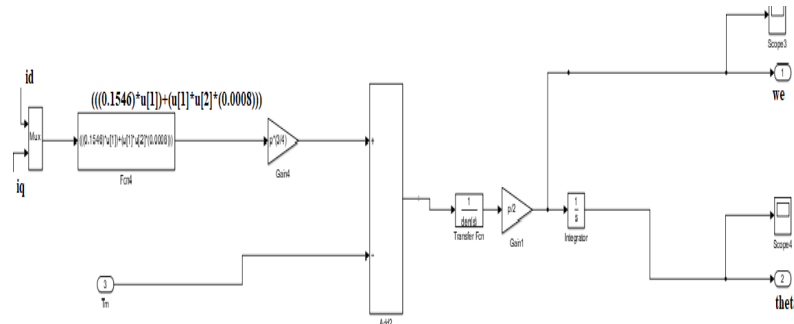

6. Dq-abc Calculation

$$I_a = i_d \cos(\theta) - i_q \sin(\theta)$$

$$I_b = i_d * \cos\left(\theta - \left(\frac{2\pi}{3}\right)\right) - i_q * \sin\left(\theta - \left(\frac{2\pi}{3}\right)\right)$$

$$I_c = i_d * \cos\left(\theta + \left(\frac{2\pi}{3}\right)\right) - i_q * \sin\left(\theta + \left(\frac{2\pi}{3}\right)\right)$$

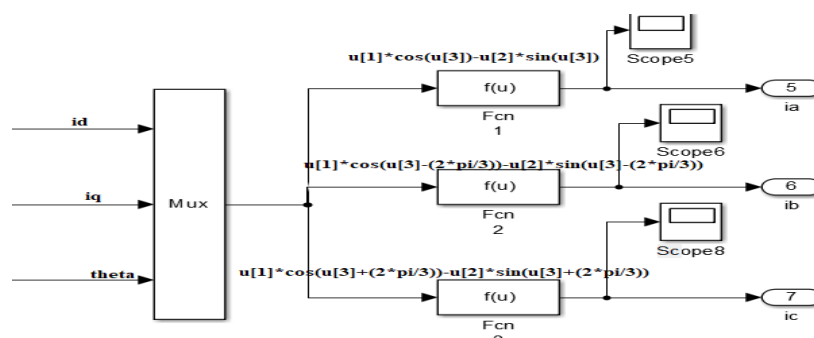

International Journal of Innovative Research in Science, Engineering and Technology

(A High Impact Factor, Monthly, Peer Reviewed Journal)

Visit: www.ijirset.com

Vol. 7, Issue 12, December 2018

VI. SIMULATION RESULT

1. Vabc to Vdq Transformation

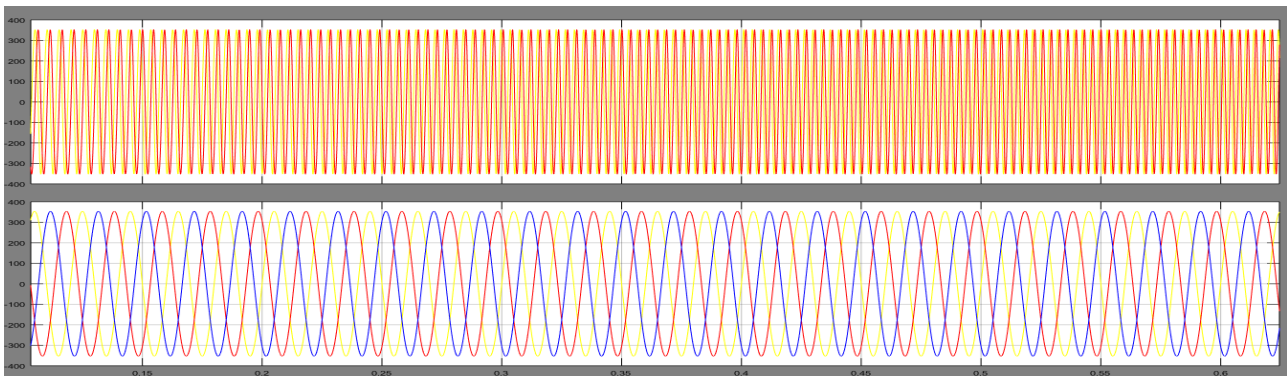

This is an output waveform of Phase voltage to Direct axis and Quadrature axis voltage.

2. IdOutput

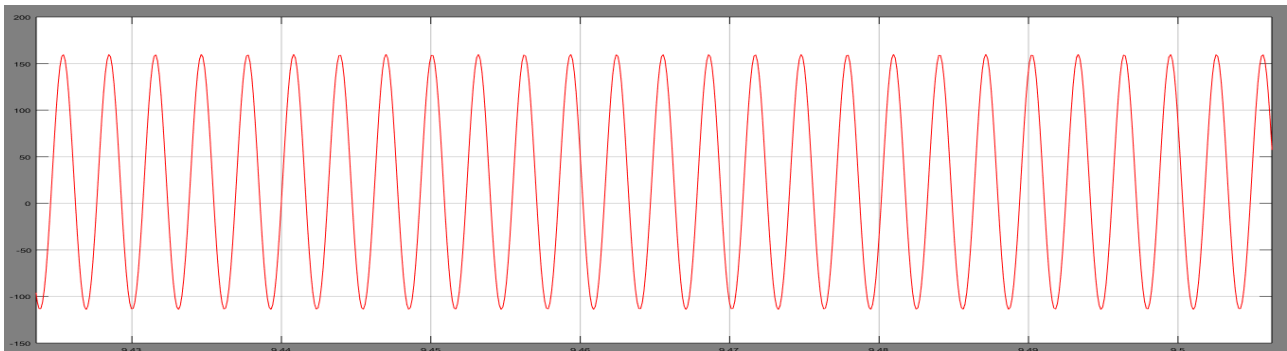

This an output waveform of direct axis current.

3. Iqoutput

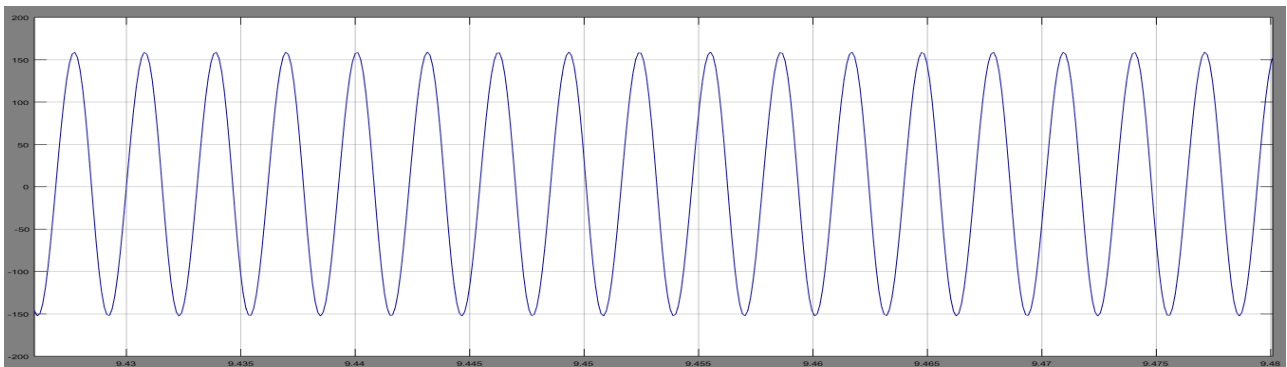

This is an Quadrature axis output current of the PMSM Motor.

International Journal of Innovative Research in Science, Engineering and Technology

(A High Impact Factor, Monthly, Peer Reviewed Journal)

Visit: www.ijirset.com

Vol. 7, Issue 12, December 2018

4. WeOutput

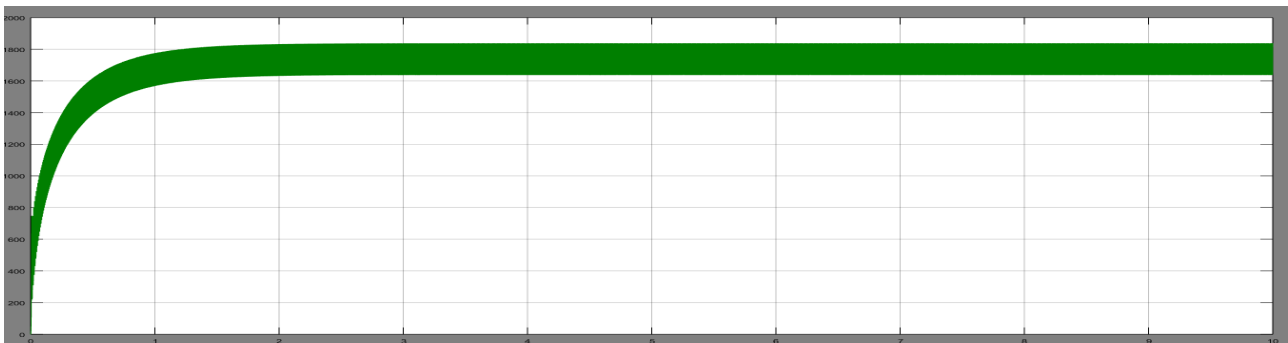

This is an waveform of the speed of PMSM Motor.

5. Theta Output

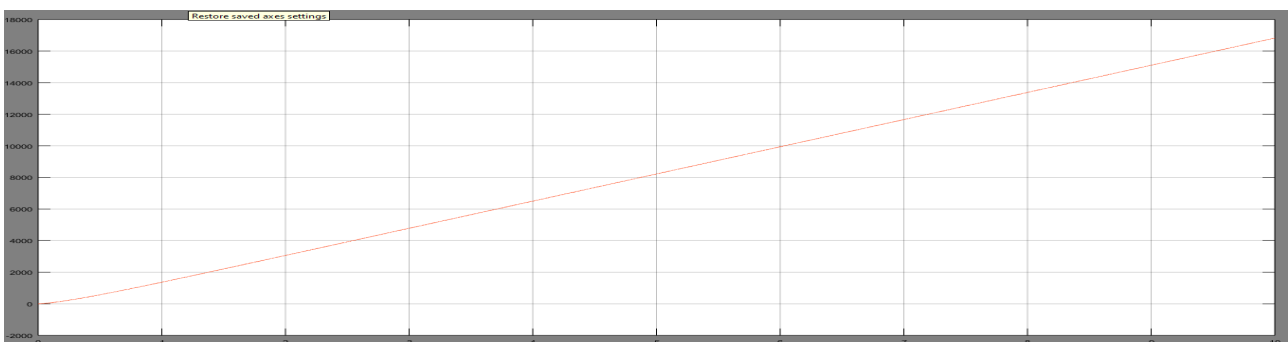

This waveform is shows the rotational angle of the PMSM Motor.

6. Dq-abccalculation

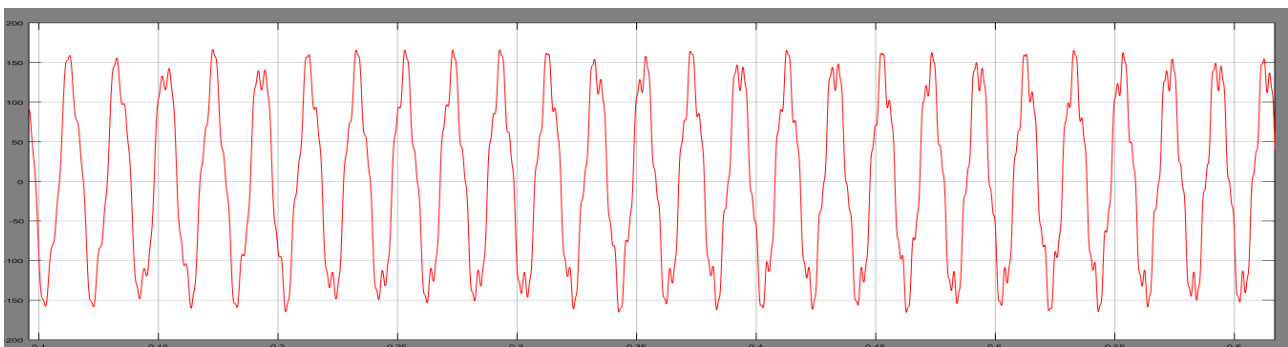

This is an output waveform of Dq to phase a.

International Journal of Innovative Research in Science, Engineering and Technology

(A High Impact Factor, Monthly, Peer Reviewed Journal)

Visit: www.ijirset.com

Vol. 7, Issue 12, December 2018

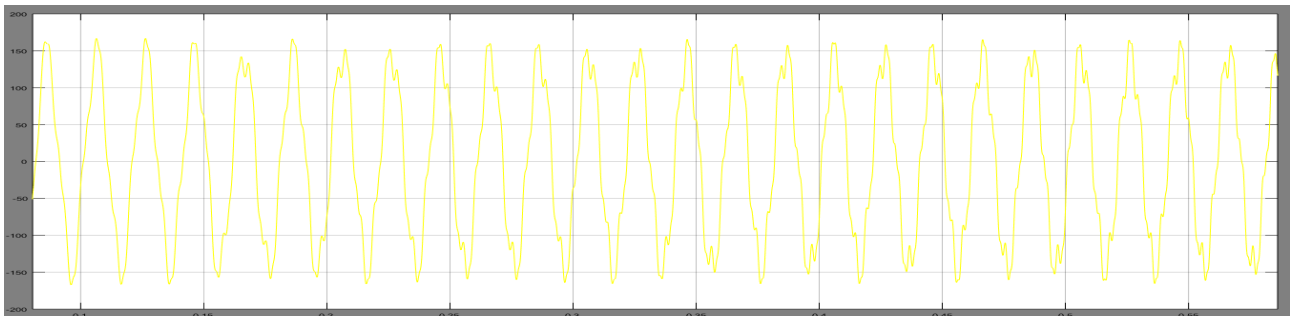

This is an output waveform of Dq to phase b.

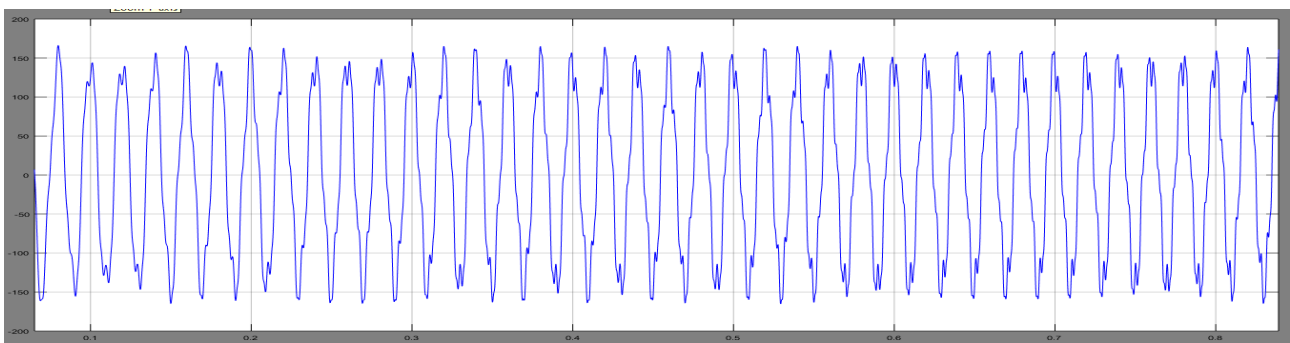

This is an output waveform of Dq to phase c.

VII. CONCLUSION

A detailed Mathematical model for a PMSM drive system with field-oriented control has being developed and operation below. Mathematical models can be easily incorporated in the simulation and the presence of numerous tool boxes and support guides simplifies the simulation of large system compared to Spice. Simulink is capable of showing real time results with reduced simulation time and debugging.

REFERENCES

1. 2T. Sebastian, G. Slemon, and M. Rahman, "Modelling of permanent magnet synchronous motors", *IEEE Transactions on Magnetics*, vol. 22, pp. 1069- 1071,1986.
2. P. Pillay and R. Krishnan, "Modeling of permanent magnet motor drives", *IEEE Transactions on Industrial Electronics* vol. 35, pp. 537-541,1988.
3. B. Cui, J. Zhou, and Z. Ren, "Modeling and simulation of permanent magnet synchronous motor drives,"2001.
4. B. K. Bose," *Modern power electronics and AC drives*", Prentice Hall,2002.
5. B. K. Bose, *Power Electronics and Variable Frequency Drives*, 1 ed: Wiley, John & Sons,1996.
6. X. Junfeng, W. Fengyan, F. Jianghua, and X. Jianping, "Flux-weakeningcontrolof permanent magnet synchronous motor with direct torque control consideration variation of parameters,"2004.
7. R. E. Araujo, A. V. Leite, and D. S. Freitas, "The Vector ControlSignal Processing blockset for use with Matlab andSimulink",1997.
8. C.-m. Ong, *Dynamic Simulation of Electric Machinery using Matlab /Simulink*: Prentice Hall,1998.
9. H. Macbahi, A. Ba-razzouk, J. Xu, A. Cheriti, and V. Rajagopalan, "A unified method for modeling and simulation of three phase induction motor drives," 2000.
10. R. Krishnan, "*Electric Motor Drives Modeling, Analysis, and Control*", Pearson Education,2001