

International Journal of Innovative Research in Science, Engineering and Technology

(A High Impact Factor, Monthly, Peer Reviewed Journal)

Visit: www.ijirset.com

Vol. 7, Issue 2, February 2018

Implementation of Virtual Channels in a Network-On-Chip Router by Using Mesh Topology

G.Gangaprasad¹, A.Chaitanyakrishna², G.Navabharat Reddy³

Assistant Professor, CMR Engineering College Medchal, Hyderabad, Telangana, India¹

Ph.D Scholar, Sri Sathya Sai University of Technology and Medical Sciences, Madhya Pradesh, India²

Assistant Professor, CMR Engineering College Medchal, Hyderabad, Telangana, India³

ABSTRACT: Network-on-Chip (NoC) introduces the design methodology of interconnection network into System-on-Chip (SoC). It overcomes the main disadvantages of traditional bus-based SoC, for example, large delay, small link bandwidth and poor scalability, etc. It is widely believed that NoC will replace bus-based architecture to become the mainstream of SoC design methodology. In NoC architecture the processing elements (PEs) communicate with each other by exchanging messages over the network and these messages go through buffers in each router. Buffers are one of the major resources used by the routers in virtual channel flow control.

KEYWORDS: Network-on-Chip(NoC); System-on-Chip (SoC); Processing Element (PE); Virtual Channel (VC); Virtual Channel Allocator (VA); Switch Allocator (SA).

I. INTRODUCTION

As the feature size is continuously decreasing and integration density is increasing, interconnections have become a dominating factor in determining the overall quality of a chip. Due to the limited scalability of system bus, it cannot meet the requirement of current System-on-Chip (SoC) implementations where only a limited number of functional units can be supported. Long global wires also cause many design problems, such as routing congestion, noise coupling, and difficult timing closure. Network-on-Chip (NoC) architectures have been proposed to be an alternative to solve the above problems by using a packet-based communication network.

In NoC, a router sends packets from a source to a destination through several intermediate nodes. If the head of packet is blocked during data transmission, the router cannot transfer the packet any more. In order to remove the blocking problem, the researcher proposed wormhole routing method. The wormhole router splits the packet into several flits which can be transferred in a single transmission. Buffer allocation and flit control are performed at a flit level in wormhole routing since wormhole routing does not allocate available buffer to whole packet. Therefore, the wormhole routing is a method which can minimize overall latency and may decrease buffer size compared to others. In addition, virtual channels are used to avoid deadlock problem and thus increase throughput. Whenever the flit arrives at or departs from router, it consumes much dynamic power depending on switch activity. Therefore, buffer design plays an important role in implementing an energy efficient on-chip network.

II. RELATED WORK

For flow control, switching techniques are mechanisms by which information is forwarded through the NoC network. Switching techniques have a significant influence on the design of router micro-architecture, and are broadly classified into circuit switching and packet switching, based on the network characteristics. Packet switching techniques are the most commonly used in current NoC designs [4]. Packet switching is further classified as Store and Forward (SAF),

International Journal of Innovative Research in Science, Engineering and Technology

(A High Impact Factor, Monthly, Peer Reviewed Journal)

Visit: www.ijirset.com

Vol. 7, Issue 2, February 2018

Wormhole (WH) and Virtual Cut through (VCT) switching. SAF switching requires large buffer size and increased latency in the router. In the VCT switching mechanism, the buffer requirements are reduced compared to the SAF switching. WH switching techniques are prone to deadlock when cyclic buffer dependencies develop from the topology and routing algorithm of the network. However, all switching mechanisms are prone to the Head-on-Line (HoL) blocking problem, which results from input buffering contention in destination routers.

To overcome the above problems in router switching techniques, researchers have proposed various buffering allocation techniques (static and dynamic), micro architectural buffer structures, and efficient buffer usage (arbitration) algorithms. The most significant improvement to WH switching is the introduction of virtual channels (VCs). J. Dally introduced the idea of the virtual channel to develop deadlock-free routing algorithms for networks that use WH routing. Earlier buffer allocation techniques proposed by various researches include: speculative allocation; traffic aware VC allocation; advance reservation control of resources; buffer size allocation, based on channel utilization; and implementing VCs, using asynchronous circuit design. Dally and Towels illustrate the basic virtual channel router architecture in interconnection networks.

III. NOC ARCHITECTURE

A generic NoC implementation consists of a number of Processing Elements (PE) arranged in a mesh-like grid, as shown in Figure 1. The PEs may be of the same type, e.g. CPU, or of different type, e.g. audio cores, video cores, wireless transceivers, memory banks etc. Each PE is connected to a local router through a Network Interface Controller (NIC); each router is, in turn, connected to adjacent routers forming a packet-based on-chip network. The NIC module packetizes /de-packetizes the data into/from the underlying interconnection network. The PE together with its NIC forms a network node. Nodes communicate with each other by injecting data packets into the network. The packets traverse the network toward their destination, based on various routing algorithms and control flow mechanisms. The heart of an on-chip network is the router, which undertakes the crucial task of steering and coordinating the data flow. Performance of Network-on-chip is determined by the router architecture to a large extent and virtual-channel router is said to be a promising choice for NoC.

IV. GENERIC ROUTER ARCHITECTURE

In general, the router has 'P' input and 'P' output channels (or ports). In most implementations, $P = 5$; four inputs from the four cardinal directions (North, East, South and West) and one from the local Processing Element (PE), which is attached to the NoC router. To minimize router complexity and traffic congestion, NoC routers are usually assumed to connect to a single PE. The input/output channels may consist of unidirectional links (as shown in Figure 2), bidirectional, or even serial links. Each router also has five components: Routing Computation (RC) Unit, Virtual Channel Allocator (VA), Switch Allocator (SA), flit Buffers (BUF), and Crossbar Switch.

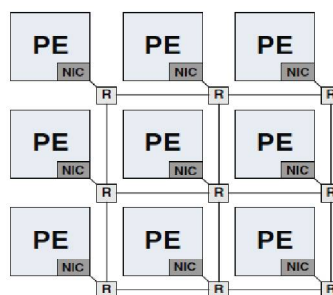

Figure 1. Generic NoC architecture

International Journal of Innovative Research in Science, Engineering and Technology

(A High Impact Factor, Monthly, Peer Reviewed Journal)

Visit: www.ijirset.com

Vol. 7, Issue 2, February 2018

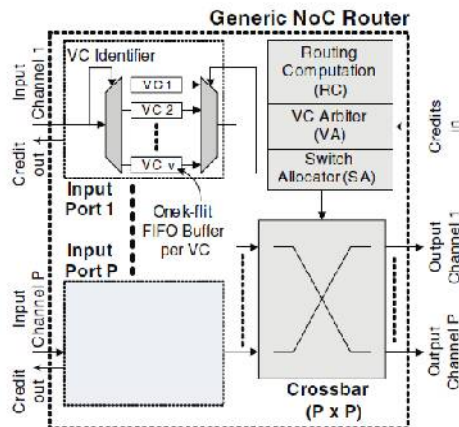

Figure 2. Generic NoC router architecture.

When the header flit arrives at the buffer, the RC unit sends incoming flits to one of physical channels. The Virtual Channel Allocation (VA) unit receives the credit information from the neighboring routers, arbitrates all the header flits which access the same VCs, and then one of them was selected. Therefore, this header flit can set up the path and then send data. The transmitting router sends the control information to the receiving router, and receiving router may update VC information at the internal buffer with this control information. SA unit arbitrates the waiting flit in all VCs accessing the crossbar and allow only one flit to access crossbar. The SA operation is based on the VA stage since the flit data in the buffer comes from the previous router in the route. The flit data pass over the crossbar and thus can arrive at the destination node. Router is a device or, in some cases, software in a computer, that determines the next network point to which a packet should be forwarded toward its destination. A router may create or maintain a table of the available routes and their conditions and use this information along with distance and cost algorithms to determine the best route for a given packet. Typical router where a packet may travel through a number of network points with routers before arriving at its destination. Buffering within a network router is necessary due to congestion, output link contention, and intra-router processing delays (e.g. routing computation), which impede data flow. In the case of virtual channel-based NoC routers, each input port consists of a number of FIFO buffers, with each FIFO corresponding to a virtual channel. Hence, each input port has 'v' virtual channels, each of which has a dedicated k-flit FIFO buffer (a flit is the smallest unit of flow control; one network packet is composed of a number of flits). This new method of GA-based optimization techniques solves a multi-objective problem that addresses NoC power consumption and interconnection resources. The GA-based technique has the ability to escape local minima and generate excellent quality solutions in reasonable time. Further, the GA-based technique can generate a set of Pareto points where each point represents a solution with a certain power and router resource consumption. Two processes take places in analyzing NoC router based on GA optimization algorithm: creating a router architecture and implementation of GA optimization algorithm. This results in identification of routing path from source to destination and creating a node for further transmission. Genetic algorithm (GA) is a search heuristic that mimics the process of natural selection. Genetic algorithms belong to the larger class of evolutionary algorithms (EA), which generate solutions to optimization problems using techniques inspired by natural evolution, such as selection, crossover, Mutation and fitness.

GENETIC ALGORITHM FLOW CHART

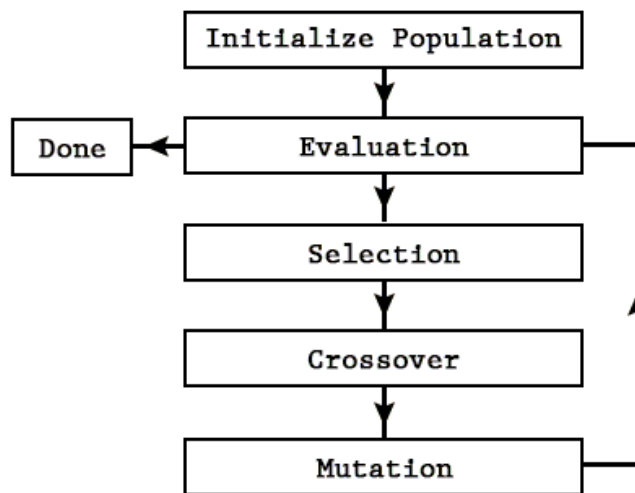

FIGURE 2

V. BUFFER ARCHITECTURE FOR GENERIC NOC ROUTER

The router buffer design is shown in Figure. 3. Router buffers can be implemented as either SRAMs (Static Random Access Memory) or as FIFO (First-In-First-Out) shift registers. FIFO registers are better suited for power-constrained area-efficient NoC architectures as SRAMs require additional area for the address decoding logic and involve higher switching activity during memory accesses. Hence a FIFO implementation is used in NoC architecture For a router architecture with ‘P’ ports, ‘v’ VCs/port and ‘k’ flit buffers/VC the total number of buffers/port is $z = vk$.

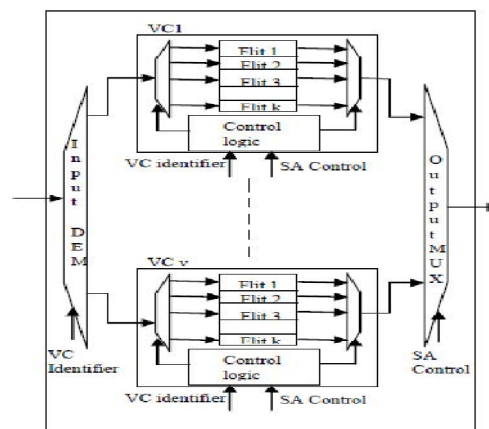

Figure 3. Buffer architecture for Generic NoC router.

In buffer architecture the VC identifier of the incoming flit allows the DEMUX to switch to the correct input VC. The RP (read pointer) and the WP (write pointer) are used to read the flit into the buffer and write the flit out to the crossbar.

International Journal of Innovative Research in Science, Engineering and Technology

(A High Impact Factor, Monthly, Peer Reviewed Journal)

Visit: www.ijirset.com

Vol. 7, Issue 2, February 2018

The RP points to the next flit to be transmitted and WP points to a null pointer indicating an empty flit to write the incoming data. When the RP reads a flit out of the buffer, a credit is returned to the upstream router to indicate that it can send another flit. The virtual channel allocator is to provide a common channel to the requestors for that VA receives neighboring router's virtual channel status and previous router's request signals and then generate virtual channel request signals with an available virtual channel of the next router. Once the virtual channel is allotted then switch allocator will grant the following flits when they arrive at flit buffers. If there are multiple requests, a SA will select the winner in a round-robin fashion for each priority level. Then the winning flit has permission to access crossbar. Crossbar is responsible for physical connection between input ports to its destined output ports, based on the grant.

VI. IMPORTANCE OF VIRTUAL CHANNEL BUFFER

The requirement of large buffering space can be solved using the wormhole switching method. In the wormhole switching method, the packets are split to flow control digits (flits) which are snaked along the route in a pipeline fashion. Therefore, it does not need to have large buffers for the whole packets but has small buffers for a few flits. A header flit build the routing path to allow other data flits to traverse in the path. The disadvantage of wormhole switching is that the length of the path is proportional to the number of flits in the packet. In addition, the header flit is blocked by congestion, the whole chain of flits are stalled. It also blocked other flits. This is called deadlock where network is stalled because all buffers are full and circular dependency happens between nodes. The concept of virtual channels is introduced to present deadlock-free routing in wormhole switching networks. This method can split one physical channel into several virtual channels. The concept of a virtual channel. Since most Network-on-Chip systems need less buffering space and has a low latency requirement, the wormhole switching method with a virtual channel is the most suitable switching method. In proposed router and advantage of both buffered as well buffer less router are achieved. In order to get the both the advantage dual cross bar is used. At low traffic condition the flit traverse from the first crossbar and at high load condition flit traverse from second crossbar using elastic buffer. There are two crossbars with the primary crossbar having four input ports, the secondary crossbar having five input ports and both of them having five output ports. The four input links are connected to both crossbars via de-multiplexers, and the injection port of the PE is connected to the last input port of the secondary crossbar. The function of processing element is to give feedback from output to input to show whether the flit is valid or not. The elastic buffer slots are connected serially, thus eliminating VCs and the corresponding virtual-channel allocator. Switch allocator is modified to control the de-multiplexers, the crossbars, and the multiplexers to maintain the correct packet flow in both crossbars. Elastic buffers (EBs) are an efficient flow-control scheme that uses the storage already present in pipelined channels instead of input virtual-channel buffers (VCBs). Removing VCBs reduces the area and power consumed by routers, but prevents the use of virtual-channel. Elastic buffer shown in Figure: 3 uses a ready-valid handshake to advance a flit (flow-control digit). An upstream *ready* (R) signal indicates that the downstream EB has at least one empty storage location and can store an additional flit. A downstream *valid* (V) signal indicates that the flit currently being driven is valid. A flit advances when both the ready and valid signals between two Elastic Buffers are asserted at the rising clock edge.

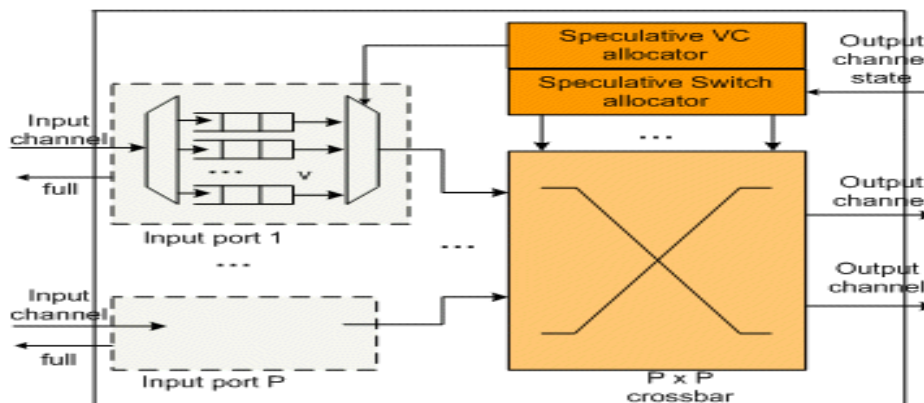

Fig:virtual channel bufferin Noc

International Journal of Innovative Research in Science, Engineering and Technology

(A High Impact Factor, Monthly, Peer Reviewed Journal)

Visit: www.ijirset.com

Vol. 7, Issue 2, February 2018

VII. IMPLEMENTATION AND RESULTS

Each input port of NoC router has 'v' virtual channels, each of which has a dedicated k-flit FIFO buffer. The necessity for very low latency dictates the use of a parallel FIFO implementation. As opposed to a serial FIFO implementation, the parallel flavor eliminates the need for a flit to traverse all slots in a pipelined manner before exiting the buffer. The NoC router design considered has 4 VCs per input port (i.e. v=4), with each VC having 4 flit buffers in the router. So the router buffer is four-flit deep (i.e. k= 4) and each flit is 32 bits long. The design is implemented in structural Register Transfer Level (RTL) Verilog and synthesized using Xilinx ISE Design Suite 12.2. The simulation result for FIFO buffer with 4 flits deep and each flit of 32 bits.

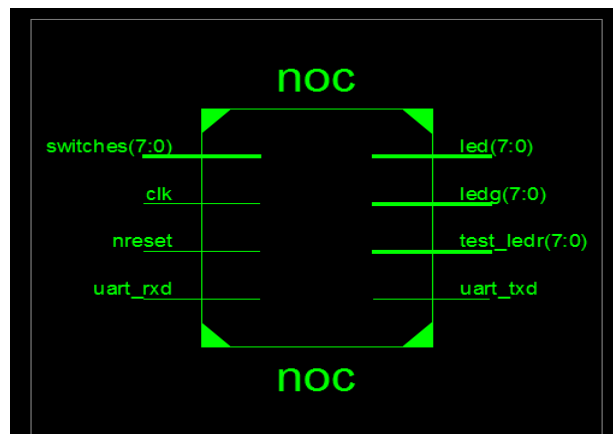

Fig: 4 RTL block diagram of Noc

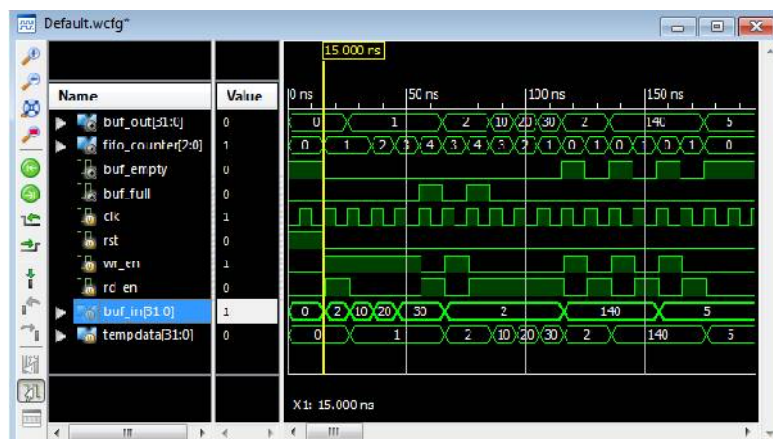

Figure 4. Simulation result for FIFO Buffer.

VIII. CONCLUSION

Since most Network-on-Chip systems need less buffering space and has a low latency requirement, the wormhole switching method with a virtual channel is the most suitable switching method. Here FIFO buffers are used as virtual channels to avoid deadlock problem and thus increase throughput.

International Journal of Innovative Research in Science, Engineering and Technology

(A High Impact Factor, Monthly, Peer Reviewed Journal)

Visit: www.ijirset.com

Vol. 7, Issue 2, February 2018

Utility summary

Number of Slices	2422	33280	7%
Number of Slice Flip Flops	2227	66560	3%
Number of 4 input LUTs	4398	66560	6%
Number of bonded IOBs	36	633	5%
Number of GCLKs	1	8	12%

Timing analysis

```
Total REAL time to Xst completion: 61.00 secs
Total CPU time to Xst completion: 60.89 secs
```

REFERENCES

- [1] W. J. Dally, "Virtual-channel flow control," IEEE Trans. Parallel Distrib. Syst., vol. 3, no. 2, Mar. 1992, pp. 194–205.
- [2] L. Benini and G. De Micheli, "Networks on chips: A new SoC paradigm," Computer, vol. 35, no. 1, 2002, pp. 70–78.
- [3] W. J. Dally and B. Towles, "Route packets, not wires: On-chip interconnection networks," in DAC '01: Proceedings of the 38th Conference on Design Automation, Jun. 2001, pp. 684–689.
- [4] A. Mello, L. Tedesco, N. Calazans and F. Moraes, "Virtual channels in networks on chip: implementation and evaluation on hermesNoC," in Proceedings of the 18th annual symposium on Integrated circuits and system design, ACM: Florianopolis, Brazil. 2005.
- [5] J. Suseela and V. Muthukumar, "Loopback Virtual Channel Router Architecture for Network on Chip," in Proceedings of the Ninth International Conference on Information Technology- New Generations. Apr. 2012, pp. 534 – 539.
- [6] L. Peh and W. J. Dally, "A delay model and speculative architecture for pipelined routers," in Proc. Int. Symp. High-Performance Comput. Architecture, Jan. 2001, pp. 255–266.
- [7] R. Mullins, A. West, and S. Moore, "Low-latency virtual-channel routers for on-chip networks," in Proc. Int. Symp. Comput. Architecture, Jun. 2004, pp. 188–197.
- [8] C. A. Nicopoulos et al., "ViChar: A dynamic virtual channel regulator for network-on-chip routers," in Proc. Int. Symp. Micro architecture, Dec. 2006, pp. 333–346.
- [9] L. Peh and W. J. Dally, "Flit-reservation flow control," in Proc. Int. Symp. High-Performance Comput. Architecture, Jan. 2000, pp. 73–84.
- [10] J. Hu, U. Y. Ogras, and R. Marculescu, "System-level buffer allocation for application-specific networks-on-chip router design," IEEE Trans. Comput.-Aided Design Integr. Circuits Syst., vol. 25, no. 12, Dec. 2006, pp. 2919–2933.
- [11] W. J. Dally, B. Towles, Principles and Practices of Interconnection Networks, Morgan Kaufmann Publishers Inc, 2003, pp. 305-324.
- [12] P. Guerrier and A. Greiner, "A generic architecture for on-chip packet-switched interconnections," in DATE'00: Proceedings of the Conference on Design, Automation and Test in Europe, Mar. 2000, pp. 250–256.
- [13] A. K. Kodi, A. Sarathy, and A. Louri, "ideal: Interrouter dual-function energy and area-efficient links for network-on-chip (noc) architectures," in Proceedings of the International Symposium on Computer Architecture (ISCA), June 2008, pp. 241–250.
- [14] Z. Lu and A. Jantsch, "Flit ejection in on-chip wormhole-switched networks with virtual channels," in NORCHIP '04: Proceedings of the 2004 IEEE/ACM International Conference on Norchip, Nov. 2004, pp. 273–276.
- [15] C. A. Nicopoulos, D. Park, J. Kim, N. Vijaykrishnan, M. S. Yousif, and C. R. Das, "ViChar: A dynamic virtual channel regulator for network-on-chip routers," in MICRO '39: Proceedings of the 39th Annual IEEE/ACM International Symposium on Microarchitecture, Dec. 2006, pp. 333–346.