

International Journal of Innovative Research in Science, Engineering and Technology

(A High Impact Factor, Monthly, Peer Reviewed Journal)

Visit: www.ijirset.com

Vol. 7, Issue 2, February 2018

Study on Load Sensing Method by Speed of PMSM

Donghoon Ban¹, Sungho Jin¹, Changhee Yoo², Seongwook Ju²

Convergence Research Center for Future Automotive, DGIST, Korea¹

R&D Center, Sangsin Brake Co. Ltd, Korea²

ABSTRACT: The PMSM is widely used in industry. In order to detect faults and to monitor the system, it is important to detect changes in load for systems in which the PMSM is installed. However, the price of sensors is high and it is difficult to install sensors because of space limitations. Therefore, a method is proposed to detect the load using the speed of the motor in a system without sensors. An FOC method for operating the motor and a detection method using speed fluctuation have been studied; however, the speed includes many error components such as motor inertia and measurement error. To improve the accuracy of the speed measurement, the pulse count method has been studied and implemented. Actual experiments were performed to verify the proposed algorithm. The proposed algorithm detects the load variation at approximately the same time as the actual load is applied.

KEYWORDS: PMSM, FOC, inverter, speed, motor.

I. INTRODUCTION

A PMSM (Permanent Magnet Synchronous Motor) is often used to operate a mechanical system or actuator. Generally, position sensors such as encoders and hall sensors, speed sensors, or current sensors are used to drive the PMSM. A load cell is installed in the system to measure the torque generated by the motor or the torque acting on the motor. When faults occur in the system, or when an external force is applied to the system, or when an actuator is hit or removed from an object during operation, the torque that is required for the system varies. So, for accuracy control, it is necessary to detect that point accurately. Therefore, it is necessary to decide when to change the control method by measuring the torque acting on the system using the load cell. It is difficult to measure the load acting on the motor when the system is moving; this difficulty is compounded because a load cell cannot be installed in the system due to space constraints. Therefore, various methods of measuring the load acting on the motor have been studied.

II. RELATED WORK

Non-salient PMSM is directly proportional to the q-axis current and torque as the torque constant. So, any change of the torque can be detected using the change of the q-axis current. To detect the torque acting on the motor in [1], the q-axis current was monitored at a constant speed. When the controller or inverter for a motor control is broken, 3-phase current balance is not established and the current fluctuation is large. Therefore, in [2], the DC link current, measured by the current sensor, is compared with the DC current calculated through FOC (Field Oriented Control) coordinate conversion to determine the malfunction of the motor and to perform load detection. If the load acting on the motor increases when the motor rotates at a constant speed, the phase current of the motor rises proportionally. Therefore, it is necessary to control the phase current of the motor to control the load acting on the motor. So, a system for regulating the load by controlling the phase current of the motor has been studied in [3]. In [4], the torque change of the motor in the EMB system was used to detect the gap between the pad and the disk. A gap control algorithm was proposed using the motor torque variation and motor rotation angle variation. The gap between the pads was estimated using the fact that the motor torque increased greatly when the brake pads contacted the disk. The FOC method for driving PMSM was studied in [5]. A motor and load equation model was made, and verified through simulation.

International Journal of Innovative Research in Science, Engineering and Technology

(A High Impact Factor, Monthly, Peer Reviewed Journal)

Visit: www.ijirset.com

Vol. 7, Issue 2, February 2018

In this paper, the speed is used to detect the point at which the load is applied. When a constant current flows through the motor, the motor rotates at its highest speed under no-load conditions. When a load is detected, the speed drops. Therefore, if the decelerating point can be accurately detected, it will be possible to accurately grasp the time at which the load acts.

III. FOC METHOD

The common method for driving PMSM is 6 step control. However, since such control is performed six times per rotation of the motor, the driving efficiency of the motor is low, and noise such as vibration is generated. FOC is used to solve this problem. A block diagram of the FOC method is presented in Fig. 1. The FOC method is used due to its two advantages of smooth and efficient operation with fast dynamic response at both low and high speeds. When the PMSM rotates, a back-electromotive force is generated. The current of the generated back-electromagnetic force is measured using phase current sensors. Using the CLARK transformation, the current measured at three phases of the motor is converted to two-phase stationary coordinates. Using the rotor position and the PARK transformation, the converted 2-phase stationary coordinates are converted to 2-phase rotational coordinates. Thus, the 3-phase AC component is converted to a 2-phase DC component. And, PI control of the d and q axes is performed using the 2-phase DC component. The d-axis represents the magnetic flux component, and the q-axis represents the torque component. The d and q axis voltages resulting from PI control are converted to 3-phase voltages using Inverse-PARK and Inverse-CLARK transformations. There are several techniques that can be used to generate the PWM (Pulse Width Modulation) for the inverter. In this paper, a space vector modulation method is used. The 6 switches in the inverter are operated depending on the PWM signals to apply 3-phase power to the motor.

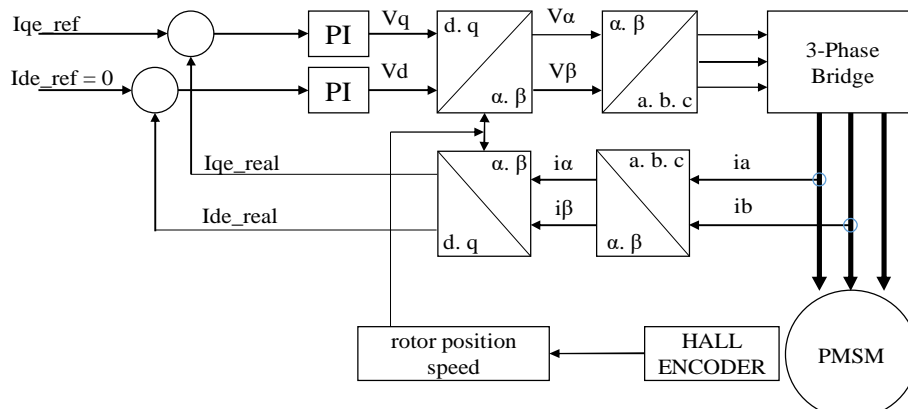

Fig. 1: Block diagram of FOC method

IV. DETECTING THE TORQUE DEPENDING ON THE SPEED

When the q-axis current is constant, the motor generates a constant torque. Equation (1) presents the torque. Equation (2) presents the power acting on the motor. Equation (3) presents the torque and motor speed.

$$T_e = \frac{3p}{2} i_q \Phi_f \quad (1)$$

where T_e is the torque, p is the pole of the motor, i_q is the q-axis current, and Φ_f is magnetic flux.

$$P = T_e \times \omega \quad (2)$$

where P is the power of the motor, T_e is the torque, and ω is the speed.

$$T_e \times w_1 = (T_e + T_a) \times w_2 \quad (3)$$

International Journal of Innovative Research in Science, Engineering and Technology

(A High Impact Factor, Monthly, Peer Reviewed Journal)

Visit: www.ijirset.com

Vol. 7, Issue 2, February 2018

where T_e is the torque of motor with no load, w_1 and w_2 are the speed of the motor, and T_a is the torque of the load.

When the torque generated by the motor is constant, the speed of the motor is w_1 . At this time, if a load is applied to the motor, the motor speed drops to w_2 . Therefore, the torque acting on the motor can be sensed using the motor speed. Since the motor speed contains many noise components due to the inertia of the motor, it is necessary to measure the speed accurately.

V. SPEED MEASURE METHOD

There are three methods including the Pulse count, Time measurement, and Pulse & Time combined methods. The Pulse count method calculates the speed using the number of pulses counted during a given sampling time. It exhibits accurate performance at relatively high speed. It also has the advantage of low computational complexity. Equation (4) presents the speed calculated by the pulse count method.

$$N = \frac{60}{T_{sample}} \cdot \frac{m}{PPR} \quad (4)$$

where N is the speed, T_{sample} is the sample time(s), m is the pulse count, and PPR is the pulses per revolution.

The time measurement method calculates the speed using the time of one pulse. Although it is possible to measure the speed accurately in a relatively low speed range, there is a disadvantage that the number of calculations increased. Also, since the speed calculation period varies depending on the speed, it is difficult to apply to a system with rapidly varying speed. Equation (5) shows the speed calculated using the time measurement method.

$$N = \frac{60}{PPR} \cdot \frac{1}{m \cdot T_{pulse}} \quad (5)$$

where PPR is the pulses per revolution, m is the pulse count, and T_{pulse} is the pulse time.

The pulse & time combined method is an appropriate combination of the above two methods. It is more accurate than the other methods, but its implementation is complicated. In addition, the measurement delay time becomes longer than the sampling time at extremely low speeds, at which the number of pulses becomes small. Therefore, there is a disadvantage in that the speed measurement period fluctuates. Equation (6) shows the speed calculated using the time measurement method.

$$N = \frac{60}{PPR} \cdot \frac{m_1}{T_s + m_2 T_c} \quad (6)$$

where PPR is the pulses per revolution, m_1 is the pulse count, m_2 is the reference clock pulse count, T_s is the sampling time, and T_c is the clock pulse time.

Because of the high encoder resolution, the speed is calculated using the pulse count method. The encoder resolution of the motor is 4,000 pulses per cycle. The speed is calculated using the pulses measured during the unit time, which is 10ms. Equation (7) presents the speed calculated in this paper. The moving average method is used as Equation (8) to reduce the inertia and measurement errors.

$$rpm = \frac{6000}{4000} \times \text{delta}_m \quad (7)$$

where delta_m is the pulses measured.

$$v_{ave} = \frac{1}{n} \sum_{i=0}^{n-1} v_i \quad (n = 5) \quad (8)$$

where v is the speed(rpm) value resulting from Equation (7).

VI. EXPERIMENT

1) **Setup** Experiments were performed to verify the proposed algorithm. The experimental system environment is presented in Fig. 2. It consists of a controller, a switch panel, a debugger, CANoe monitoring equipment, and a motor dynamo. The motor speed was measured by the pulse count method using the Hall / Encoder signal and was verified by

International Journal of Innovative Research in Science, Engineering and Technology

(A High Impact Factor, Monthly, Peer Reviewed Journal)

Visit: www.ijirset.com

Vol. 7, Issue 2, February 2018

the tachometer. The CANoe monitoring equipment is used to monitor the motor speed, the current value of the q-axis, and the torque detection time. The motor and controller specifications are presented in Table 1. The dynamo specifications are presented in Table 2.

Table 1: Specifications of the motor and controller

	Task	Specification
MOTOR	Model number	MAXON EC-4Pole
	Electric resistance	0.386Ω
	Inductance of d-axis	0.0653mH
	Inductance of q-axis	0.0653mH
	Torque Constant	0.0276Nm/A
	Rotor Inertia	0.00000333 kgm ²
	Pole Pair	2
	Magnetic flux	0.0092V.S
CONTROLLER	Operating type	Sinusoidal control
	rated phase current	100A
	DC Link Voltage	48V

Table 2: Specifications of the dynamo

Task	Specification
Model number	FMAKN05-AB
Rated Power	250W, 2.15N-m
speed	2000rpm
Maker	HIGEN Motor Co. Ltd

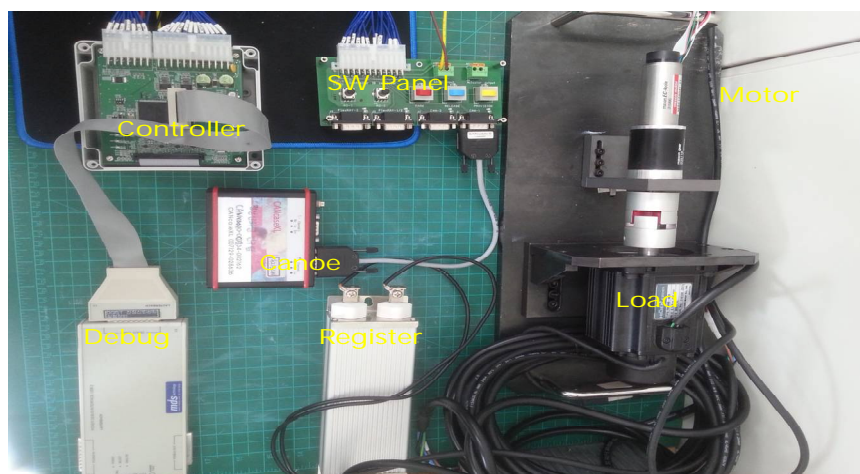

Fig. 2: Picture of the experimental system environment

2) **Result** The proposed algorithm was verified by measuring the time to detect various loads applied under various conditions such as low speed and high speed. The detecting time depending on the motor speed when a load is

International Journal of Innovative Research in Science, Engineering and Technology

(A High Impact Factor, Monthly, Peer Reviewed Journal)

Visit: www.ijirset.com

Vol. 7, Issue 2, February 2018

applied to the motor, is presented in Table 3. If a speed PI controller is used, the speed does not change due to the performance of the speed PI controller. So, the motor speed was adjusted according to the current reference of the q-axis. That is, the motor speed is the result of the current PI control.

Since the speed fluctuation is large when the motor rotates fast, the load detection time of the system drops. At low speed, the load detection was good, but load detection time was long. At high speed, the load detection was not good because of the variation range of the speed, which includes noise components such as inertia and production deviations of the motor.

Table 3: Detecting time depending on speed and load

Motor speed	Applied Load(N-m)	Detecting Time (ms)
1,000	0.1	36
	0.3	20
	0.5	15
3,000	0.1	41
	0.3	7
	0.5	6
5,000	0.1	12
	0.3	5
	0.5	4

VII. CONCLUSION

The PMSM is widely used in industry. For the detection of faults and monitoring of the system, it is important to detect changes in the load in systems in which a PMSM is installed. However, the price of sensors is expensive and it is difficult to install sensors because of space limitations. Therefore, a method to detect load using the speed of the motor in a system without a sensor is proposed. The FOC method for operating the motor is studied and a detecting method using the speed fluctuation is studied. However, the speed includes many error components such as motor inertia and measurement errors. To improve the accuracy of the speed measurement, the pulse count method is implemented. Actual experiments were performed to verify the proposed algorithm. The proposed algorithm detects load variation at approximately the same time as an actual load is applied.

VIII. ACKNOWLEDGEMENT

This research was supported by the Ministry of Trade, Industry & Energy(MOTIE), Korea Institute for Advancement of Technology(KIAT) through the Encouragement Program for The Industries of Economic Cooperation Region) R0003913

REFERENCES

- [1] D. H. Ban, S. H. Jin, and J. S. Hong, "The study about the load sensing method of BLAC motor," 2016 Proceeding of IEMEK, 304-306.
- [2] D. H. Ban, J. S. Hong, and S. H. Lee, "Diagnostic of the inverter / the motor using DC current," 2016 Proceeding of ICROS.
- [3] B. J. Lim, and C. D. Park, "Development of Load apparatus for Motor," KSFJ journal, 12(6), 2009, 26-32.
- [4] C. H. Jo, S. H. Hwang, and H. S. Kim, "Estimation of Clamping-force and Development of Gap-distance Control Algorithm for Electro-Mechanical Brake," 2009 Proceeding of KSAE, 665-670.
- [5] Y. D. Kiran, P. S. Puttaswamy, "Field Oriented Control of a Permanent Magnet Synchronous Motor using a DSP," International Journal of Advanced Research in Electrical, Electronics and Instrumentation Engineering, 3(10), 12364-12378, 2014.
- [6] D. H. Ban, S. H. Lee, and J. S. Hong, "Rotor Position Estimation of Permanent Magnet Synchronous Motors Using Low-Resolution Sensors", International Journal of Fuzzy Systems, Vol. 19, No. 1, pp. 78-85, 2016
- [7] Z. Qiao, T. Shi, T. Wang, Y. Yan, C. Xia, and X. He, "New Sliding-Mode Observer for Position Sensorless Control of Permanent-Magnet Synchronous Motor", IEEE Transactions on industrial electronics, Vol.60, No.2, pp.710-719, 2013

International Journal of Innovative Research in Science, Engineering and Technology

(A High Impact Factor, Monthly, Peer Reviewed Journal)

Visit: www.ijirset.com

Vol. 7, Issue 2, February 2018

- [8] X. G. Yan, and C. Edwards, "Nonlinear robust fault reconstruction and estimation using a sliding mode observer", *Automatica* 43, pp.1605-1614, 2007
- [9] J. I. Ha, K. Ide, T. Sawa, and S. K. Sul, "Sensorless Rotor Position Estimation of an Interior Permanent-Magnet Motor From Initial States", *IEEE TRANSACTIONS ON INDUSTRY APPLICATIONS*, Vol.39, No.3, pp.761-767, 2003
- [10] R. Wu, and G. R. Slemon, "A Permanent Magnet Motor Drive Without a Shaft Sensor", *IEEE TRANSACTION ON INDUSTRY APPLICATIONS*, Vol.27, No.5, pp.1005-1011, 1991
- [11] C. S. Li, and M. Elbuluk, "A Sliding Mode Observer for Sensorless Control of Permanent Magnet Synchronous Motors", *Industry Applications Conference*, 2001. Thirty-sixth IAS Annual Meeting Conference Record of the 2001 IEEE, Vol.1, pp.1273-1278, 2001
- [12] Y. Feng, J. Zheng, X. Yu, and N. V. Truong, "Hybrid Terminal Sliding-Mode Observer Design Method for a Permanent-Magnet Synchronous Motor Control System", *IEEE TRANSACTIONS ON INDUSTRIAL ELECTRONICS*, Vol.56, No.9, pp.3424-3431, 2009
- [13] B. K. Kim, W. K. Chung, and K. Ohba, "Design and Performance Tuning of Sliding-Mode Controller for High-Speed and High-Accuracy Positioning Systems in Disturbance Observer Framework", *IEEE TRANSACTIONS ON INDUSTRIAL ELECTRONICS*, Vol.56, No.10, pp.3798-3809, 2009

BIOGRAPHY



Donghoon Ban He received the B. S. degrees in electrical engineering from Donga University, Busan, Korea in 1999; the M.S. degree in electrical engineering from Pusan University, Busan, Korea in 2006; and the Ph. D. degree in electrical engineering from Donga University, Busan, Korea in 2013. He is a senior research engineer at Daegu Gyeongbuk Institute of Science & Technology (DGIST). He is developing the components of vehicles such as Body Control Module, Electronic Parking Brake, and Electronic Mechanical Brake base on AUTOSAR. His research interests are Fuzzy control, PMSM control, inverters and AUTOSAR.



Sungho Jin He received the B. S. degrees in electrical He received the B.S. and M.S. degrees in electronics engineering from Kyungpook National University, Daegu, Korea, in 1989 and 1991, respectively. He is a Principal Research Engineer with the Daegu Gyeongbuk Institute of Science and Technology, Daegu, Korea. His research interests include automotive embedded systems, modeling and simulation for electric vehicles, and motor application systems.