

# International Journal of Innovative Research in Science, Engineering and Technology

(A High Impact Factor, Monthly, Peer Reviewed Journal)

Visit: [www.ijirset.com](http://www.ijirset.com)

Vol. 7, Issue 6, June 2018

## PLC based Data Transmission System

Rashmi Sharma

Assistant Professor, Department of Electrical & Electronics Engineering, Indus University, Gujarat, India

**ABSTRACT:** Now a days power line is getting wide acceptance for sending control signals and communication signals. It has the advantage of less initial expenses to establish a communication network. In this paper power line is used for transmitting data using simple power line communication interface. Wireless devices are operated by using storage cell or utility power. With wireless devices huge investment is required to automate the complete home which is just function specific. The outcome of this paper can become a part of such product which can be plugged in to all devices which are connected to power line. This method provides affordable and integrated solution for home automation.

**KEYWORDS:** PLC modem, Arduino, LCD, Remote control application.

### I. INTRODUCTION

As technology advances and more technologies are developed and used by society, our demand for electricity will increase at unpredictable rates. In fact, on a daily basis power companies are faced with the challenge of distributing power through their power grids without disrupting the flow of electricity to other users. However, when there is a sudden increase in the demand for power in a part of the power grid then there can be disastrous effects. When the load is too great for a power grid there can be outages that can cost the economy millions of dollars and this is simply unacceptable.

Many times it is not by fault of the power company that these outages occur, but mainly due to mechanical failures at certain nodes or unexpected increases in power consumption at particular nodes. Power-on-Demand cannot decrease the occurrence of outages due to mechanical failures, but it can decrease the chances of outages occurring due to unexpected increases in demand for power. Power-on-Demand is gaining support because of the functionality it purports. Using this technology, power companies can communicate with their large industrial clients on an ongoing basis and be assured that their power demands will be met. This will decrease the probability of an outage being caused by those clients and increase the efficiency of the power network. The motivation is simple create efficient power networks by communication. If companies are successful in implementing Power-on-Demand systems, then this technology can be further developed to offer other services using Power Line Data Transmission.

Power line communication has been around for quite some time, but has only been used for narrow band tele-remote relay applications, public lighting and home automation. Broadband over PLC only began at the end of the 1990s. Although its use is expanding into the distribution area for load control and even into households for control of lighting, alarming and a/c and heating, the major application is on Transmission Lines in Protective relaying. A channel is used in line relaying so that both ends of a circuit are cleared at high speed for all faults, including end zone faults.

### II. METHODOLOGY

In this project the data is being transferred over AC line, which is encoded and decoded by PLC modem. In this the source information is generated by a key board and this will be sent to destination through power line modem. The receiving system will check the data and displays on the LCD. The transmitter stage must be carefully designed to take digital signals from the MCU, filter them to eliminate out of band emissions and drive the low impedance of the AC power line. In receiver section of the power line module receive the data through the power line communication modem and send to the receiver section of the microcontroller unit and display on the LCD. The basic block diagram of the project is shown in Fig.1

# International Journal of Innovative Research in Science, Engineering and Technology

(A High Impact Factor, Monthly, Peer Reviewed Journal)

Visit: [www.ijirset.com](http://www.ijirset.com)

Vol. 7, Issue 6, June 2018

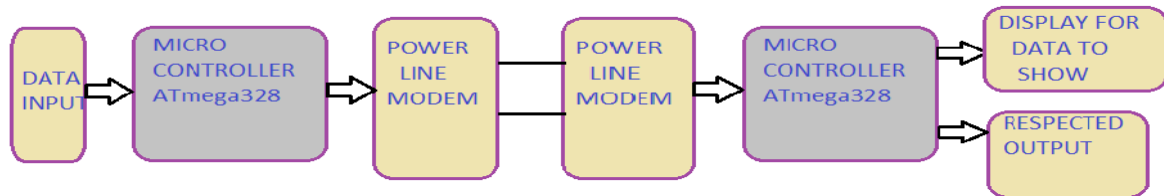

Fig.1 Block diagram

### III. POWERLINE COMMUNICATION MODEM(PLC)

Power line modem is useful to send and receive serial data over existing AC mains power lines of the building. It has high immunity to electrical noise persistence in the power line and built in error checking so it never gives out corrupt data. The modem is in form of a ready to use circuit module, which is capable of providing 9600 baud rate low rate bi-directional data communication. Due to its small size it can be integrated into and become part of the user's power line data communication system.

The module provides bi-directional half-duplex communication over the mains of any voltage up to 250V AC and for frequency 50Hz or 60Hz. Half Duplex communication means it can either transmit or receive data at a time but not both at same time. Normally module is in receiving mode all the time listening to incoming communication on the power line. Once your application gives serial data to transmit on its RX-IN pin, it switches over to transmit and transmits the data through power line.

Once transmit process is complete it switches back to receive mode. The transmission of data is indicated by Red LED. The reception of data by modem is indicated by Green LED which is on TXout pin itself. Data communication of the modules is transparent to user's data terminals and protocol independent; as a result, multiple units can be connected to the mains without affecting the operation of the others.

There is no hassle of building interface circuits. Interface to user's data devices is a simple data-in and data-out serial link. Transmission is based on byte by byte basis. Once you give one byte to module for transmission, you will have to wait at least 500ms before a new byte is given to module again since the module waits for zero crossing of AC mains to transfer a bit. For AC 50Hz system the zero crossing of AC signals happens every 10ms and modem needs 50 zero crossings to transmit one byte with error checking data.

That is why it takes 500ms for one byte. For example we want to transmit character "TEST", then we will have to transmit 'T', then wait 500ms, then transmit 'E' and wait 500ms, then transmit 'S' and wait 500ms, then transmit 'T' and wait 500ms. This can be quite slow speed for big data transfer, but the purpose of this module is transfer of small data bytes like sensor readings and remote control for which this speed is ok to implement. The application diagram of the system is shown in Fig.2.

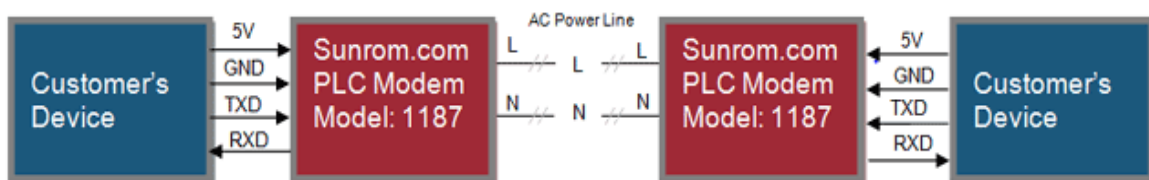

Fig.2 Application diagram

# International Journal of Innovative Research in Science, Engineering and Technology

(A High Impact Factor, Monthly, Peer Reviewed Journal)

Visit: [www.ijirset.com](http://www.ijirset.com)

Vol. 7, Issue 6, June 2018

The module is interfaced directly with microcontroller pins since the level of module is at 5V level. You can use any microcontroller like 8051, AVR, PIC or such. Just configure your microcontroller to communicate at 9600 baud rate. The TXD pin of MCU will go to RX-IN pin of PLC modem The RXD pin of MCU will go to TX-OUT pin of PLC modem Ground & +5V Power Supply between PLC modem and MCU should be connected. Fig.3(a) Serial Interfacing with Micro controller.

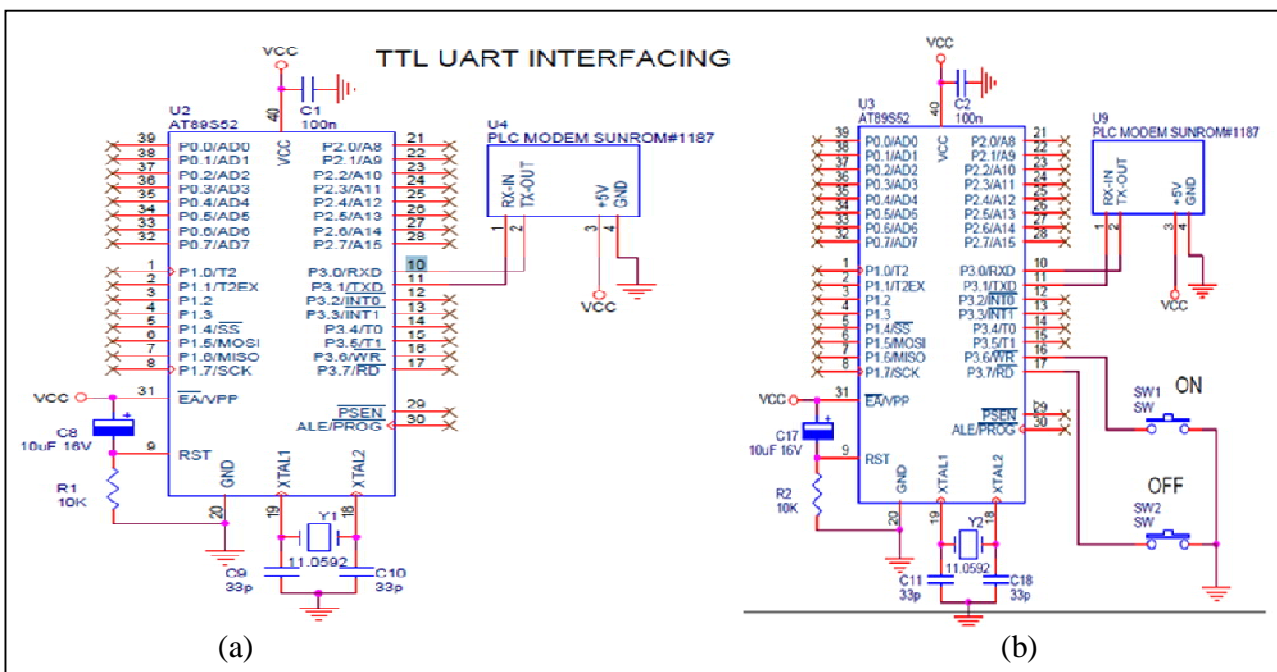

Fig.3 (a) Serial Interfacing with Micro controller; 3(b) Diagram of Remote control application

To show what the PLC modem is capable of we will see one remote control application. In this application there will be first unit which will be control panel with ON and OFF switch. When ON switch is pressed, character 'A' is transmitted, When OFF switch is pressed character 'B' transmitted through PLC modem. The receiver side listens to the data through power line modem and switches on or off relay accordingly. Source Code for this application can be downloaded from product page. The source code is in Keil C51 compiler. Diagram of Remote control application is shown in Fig.3 (b)

## IV. EXPERIMENTAL RESULTS.

The data is successfully transmitted over the power lines by using power line module and arduino board by keeping switches on transmitter side while relay board on other side which is operated through switches on transmitter side and they are connected through power lines only i.e at 230V. The data is transmitted in twice or thrice the speed of normal broadband networking. There was no data loss during transmission which is also a big advantage of using this technology. In this we don't require any separate lines for transmission of data. It can be transmitted through power lines only. During the project we observed that the data is transmitted in twice or thrice the speed of normal broadband networking. There was no data loss during transmission which is also a big advantage of using this technology. In this we don't require any separate lines for transmission of data. It can be transmitted through power lines only. Fig.5 (a), (b) and (c) shows the RX, TX Power line Communication and hardware connection respectively.

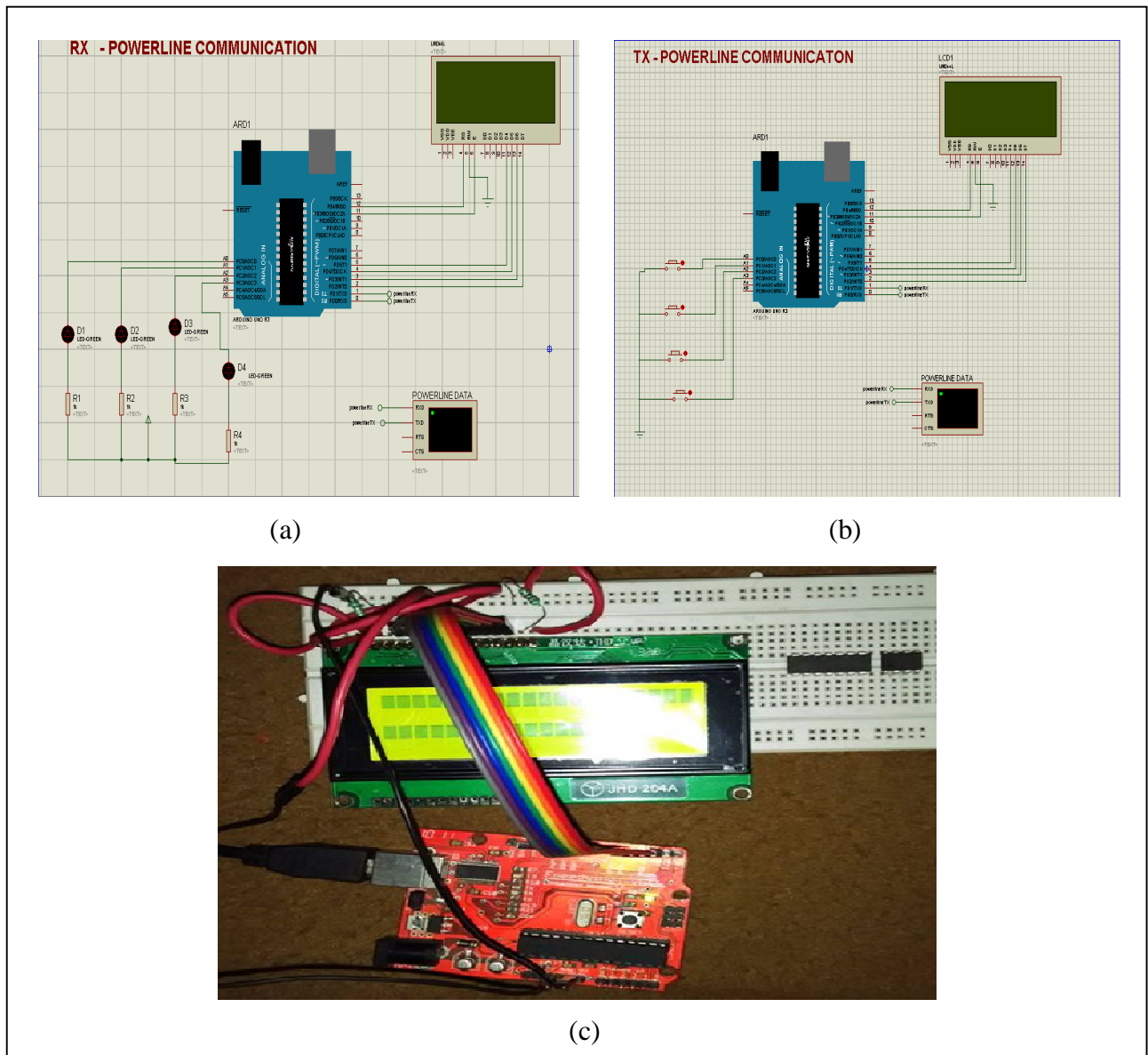

Fig.5 (a) RX-Power line Communication; (b) TX-Power line Communication; (c) Hardware Connection

## V. HOME NETWORKING OVER POWER LINES

In the present digital age of information technology, the demand for sending digital voice, video, and Internet data to and around a home, office or other building increases continuously. Installation of wires to support this is expensive, disruptive and time consuming process. In the context of a home networking environment, “no new wires” is the term applied to a suit of technologies that utilize the existing wiring systems to distribute high-speed data and video throughout the home (or small office).

# International Journal of Innovative Research in Science, Engineering and Technology

*(A High Impact Factor, Monthly, Peer Reviewed Journal)*

Visit: [www.ijirset.com](http://www.ijirset.com)

Vol. 7, Issue 6, June 2018

## VI. IMPLEMENTATION

To visualize the working of power line modem visualizing of the data transfer is done using human interface visualization. A keyboard is used as input device and LCD display is used as output device. At higher level PC to PC communication is done. In the PC a hyper terminal will display the key that is pressed and at the other end it will display the received message.

## VII. CONCLUSION

PLC solutions may be seen as complementary or alternative solutions to traditional fixed line networks, wireless networks and VDSL networks. According to existing network architectures, buildings or technical constraints, either solution can be chosen, but one can also consider one solution to complement another. PLC bandwidths are set to increase, the Home plug AV standard is being considered for broadcasting digital television. Many research projects are ongoing into these solutions and their applications, it is all to come, and one should pay close attention to news about this technology.

## REFERENCES

- [1] Korhonen, "Powerline Communication over Special Systems", Power Line Communications and Its Applications, 2005 International Symposium on 6-8 April, 2005 Page(s):167 - 171
- [2] Dave Rye, "The X-10 Powerhouse, Power Line Interface", [Online], Available: <http://www.hometoys.com>
- [3] Phil Kingery, "Home Toys Article- Digital X-10", - Feb99 – [Online], Available: <http://www.hometoys.com>.
- [4] PLM-01- PLM-24 Power Line Modem, User's manual and assembly guide, [Online], Available: <http://www.lorix.it>.
- [5] J. Huloux, L. Hanus, "ST7537 Power Line Modem Application", SGSThompson Application Notes [Online], Available: <http://www.lorix.it>.
- [6] ST7535HS1 Home Automation Modem, Datasheet, June 1995, SGSThompson, [Online], Available: [www.st.com](http://www.st.com)
- [7] Matthias Karl, Klaus Dostert, "Selection Of An Optimal Modulation Scheme For Digital Communications Over Low Voltage Power Lines", , Spread Spectrum Techniques and Applications Proceedings, 1996
- [8] Petra Cuntic, Alen Baiant, "Analysis of Modulation Methods for Data Communications over the Low-voltage Grid", Proceeding of the 7<sup>th</sup> International Conference on Telecommunication – ConTEL 2003 – June 11-13, Zagreb, Croatia