

Selection & Performance Analysis of Spreading Sequences for DS-CDMA Systems

Darshini M B¹, Anupama Shetter²Assistant Professor, Department of Electronics & Communication Engineering, ATME College of Engineering,
Mysuru, Karnataka, India¹Assistant Professor, Department of Electronics & Communication Engineering, ATME College of Engineering,
Mysuru, Karnataka, India²

ABSTRACT: In CDMA, spread spectrum technology is used where unique code is assigned to each user and allows multiple users to be multiplexed over the same physical channel. Direct Sequence Code Division Multiple Access (DS-CDMA) wireless transmitter design using FPGA, is a type of spread-spectrum communication system in which multiple signal channels occupy the same frequency band, being distinguished by the use of different spreading codes, which has been adopted in many wireless access technologies. Digital approach is used to design four separate blocks to form the transmitter circuit diagram using the Oscillator, PN-code generator, Parity Check, and BPSK modulator. In the same way at receiver side, the BPSK demodulator is used to recover the original message signal. The Xilinx ISE software and Mentor Graphics software has been used for the design synthesis and simulation and the VHDL program was used for coding. The DS-CDMA wireless transmitter was designed to transmit with data rates up to 2Mbps. The transmitted signals were carried with a 40 MHz carrier frequency.

KEYWORDS: PN Sequence, Multiple access, Spread spectrum, modulator, demodulator.

I. INTRODUCTION

Today spread spectrum communications is the widely used data communication scheme. It has many suitable features to secure, multiple accesses and many other properties that are required in a communication system. Spread spectrum is one of the means of transmission in which the bandwidth will be in excess of the minimum necessary in a signal to send the information. The code is used to achieve the band spread, which is independent of the data and synchronized reception with the code, for despreading and subsequently data recovery the code at the receiver is used. The transform of an information signal is the purpose of coding which looks almost like noise. Resistance to interference and short range interferences- free overlays on their emissions, from other emissions and detestability are the several possible advantages of spreading or dilution of energy in spread spectrum systems over a wide bandwidth. The low spectral density needed for spread spectrum communication systems as well as ability of some of these systems.

In both industry and academia into the development of CDMA systems, performance of a significant amount of research has been done in recent years. A clear description of a CDMA has been exclusive, to every researcher involved in the topic, it has a different meaning. DS-CDMA is a type of spread-spectrum communication system, in which being distinguished by the use of different spreading codes, multiple signal channels occupy the same frequency band. The communication employed is CDMA communication, personal communication services and digital cellular telephone systems are the example. In these systems, a plurality of mobile stations is communicated by a base station, for all of the up-links from the mobile stations one frequency band being used to the base station and for all of the down-links from the base station to the mobile stations another frequency band being used. The pseudo random PN coding and synchronization of a wireless transmitter for DS-CDMA is described using the design and a circuit for using VHDL software. Basic digital components, such as flip-flops, oscillators, shift registers, PN coder and a BPSK modulator are comprised in the circuit for the transmitter.

International Journal of Innovative Research in Science, Engineering and Technology

(A High Impact Factor, Monthly, Peer Reviewed Journal)

Visit: www.ijirset.com

Vol. 7, Issue 6, June 2018

II. SPREAD SPECTRUM MULTIPLE ACCESS

Spread spectrum multiple access (SSMA) uses signals which have a transmission bandwidth and the signal is of several orders of magnitude greater than the minimum required RF bandwidth. Conversion of a narrowband signal to a wideband noise-like signal is done by a pseudo-noise (PN) sequence before transmission. SSMA provides immunity to multipath interference and robust multiple access capability. When used by a single user, SSMA is not very bandwidth efficient. However, since without interfering with one another, many users can share the same spread spectrum bandwidth. In a multiple user environment, Spread spectrum systems become bandwidth efficient. There are two main types of spread spectrum multiple access techniques; Direct sequence multiple access (DS) and frequency hopped multiple access (FH). Direct sequence multiple access is also called code division multiple access (CDMA).

The bandwidth of the signal can be spread through three types of spread spectrum techniques.

They are:

- Frequency Hopping(FH): There will be rapid pseudo-random switching of signals between different frequencies within the hopping bandwidth and at any given time the receiver knows where to find the signal.
- Time Hopping (TH): Transmission of the signals takes place in short bursts pseudo-randomly, and the receiver knows that when to expect the burst, beforehand.
- Direct Sequence (DS): At a much higher frequency, the digital data is directly coded. The pseudo-random code is generated, the receiver knows how to generate the same code, and correlates the received signal with that of code to extract the data.

III. DESIGN OF DIRECT SEQUENCE SPREAD SPECTRUM SYSTEM

Direct Sequence-Spread Spectrum (DS-SS) is one of the transmission technique in which a pseudo-noise code is employed as a modulation waveform to “spread” the signal energy over a bandwidth, independent of the information data, where bandwidth is much greater than the signal information bandwidth. Using a synchronized replica of the pseudo-noise code, de-spreading of the signal is done at the receiver end. In DS-SS, the spreading sequence is often called as PN sequence.

In this section, Binary Phase Shift keying (BPSK) modulation technique is used to modulate the spread signal in the transmitter and BPSK demodulation technique is used to recover the modulated signal on the receiver side. The basic building blocks of DS-SS system are shown in Fig. 1.

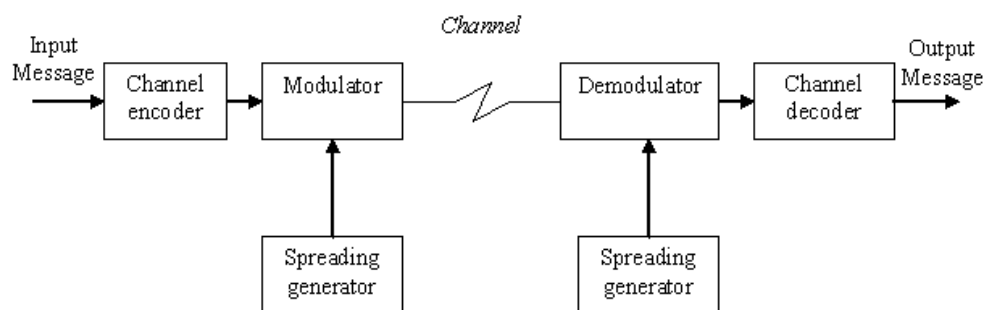

Fig. 1. Basic building blocks of DS-SS system

IV. PN SEQUENCE GENERATOR

A Pseudo-Random Noise (PN) sequence/code is one of the binary sequences that exhibits randomness properties and deterministic (has a finite length). PN generators are heart of every spread spectrum system. Each symbol or bit in the

International Journal of Innovative Research in Science, Engineering and Technology

(A High Impact Factor, Monthly, Peer Reviewed Journal)

Visit: www.ijirset.com

Vol. 7, Issue 6, June 2018

sequence is called as Chip. PN generators are based on Linear Feedback Shift Registers (LFSR). At each clock cycle right shifting of the contents of the registers are done by one position. The feedback from predetermined registers or taps to the left most register is XNOR-ed together.

There are several variables of LFSRs:

- The number of stages in the shift registers
- The number of taps in the feedback path
- The position of each tap in the shift registers stage
- The initial starting conditions of the shift registers or “FILL” state.

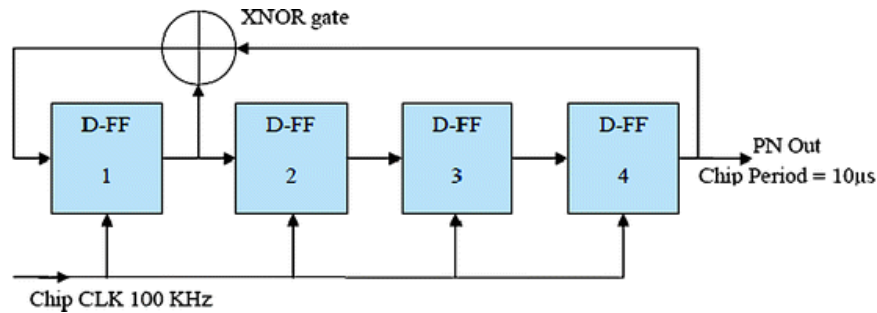

Fig. 2. Block diagram of PN sequence generator

The duration of the PN sequence before it repeats is as longer as the number of stages of shift registers in the PN generator, longer. For a shift register of fixed length N, the number and position of taps used to generate the parity feedback bit are used to determine the number and duration of the sequences that it can generate.

A maximum length sequence (L) for a shift register of length N is referred to as m-sequence and is defined as:

$$L = 2^N - 1 \quad (1)$$

E.g. an eight stage LFSR will have a set of m-sequences of length 255.

V. DESIGN & IMPLEMENTATION OF DS-SS TRANSMITTER AND RECEIVER

In DS-SS transmitter, the input data bits are spread by PN sequence generator. The data bits are multiplied with the generated PN sequence code in order to perform spreading. Data signal is lesser than that of the frequency of PN sequence. After spreading, the Data signal is modulated and transmitted. Modulation is done in many several available schemes, viz. M-QAM, BPSK, QPSK, etc. BPSK modulation scheme is the most widely used. In this design, to modulate and transmit the spread signal BPSK modulation is used. The basic building blocks of a simple DS-SS transmitter system are shown in Fig-3.

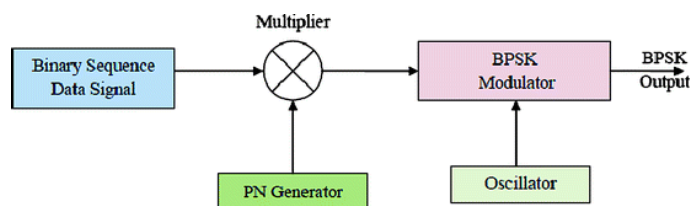

Fig. 3. Block diagram of a DS-SS transmitter system

International Journal of Innovative Research in Science, Engineering and Technology

(A High Impact Factor, Monthly, Peer Reviewed Journal)

Visit: www.ijirset.com

Vol. 7, Issue 6, June 2018

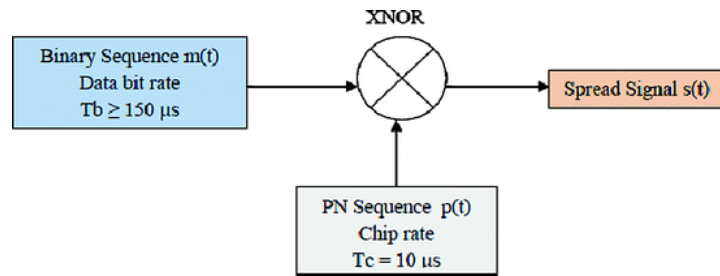

Fig. 4. Block diagram of a data and PN sequence multiplier

TABLE. 1. Truth table for the multiplier

m(t)	p(t)	s(t)
0	0	1
0	1	0
1	0	0
1	1	1

Multiplier Design Specifications:

- PN sequence Chip rate, $T_c = 10 \text{ ms}$.
- Data signal Bit rate, $T_b > 150 \text{ ms}$.

Let the data signal be $m(t)$ and PN sequence $p(t)$. The two signals are multiplied and the multiplied output is the spread signal. Truth table for the multiplier $s(t) = m(t) \cdot p(t)$ is shown in Table-1. From the truth table, it can be inferred that to spread the data signal with the PN signal, an XNOR gate can act as a multiplier. Hence the block diagram for the multiplier is shown in Fig. 4.

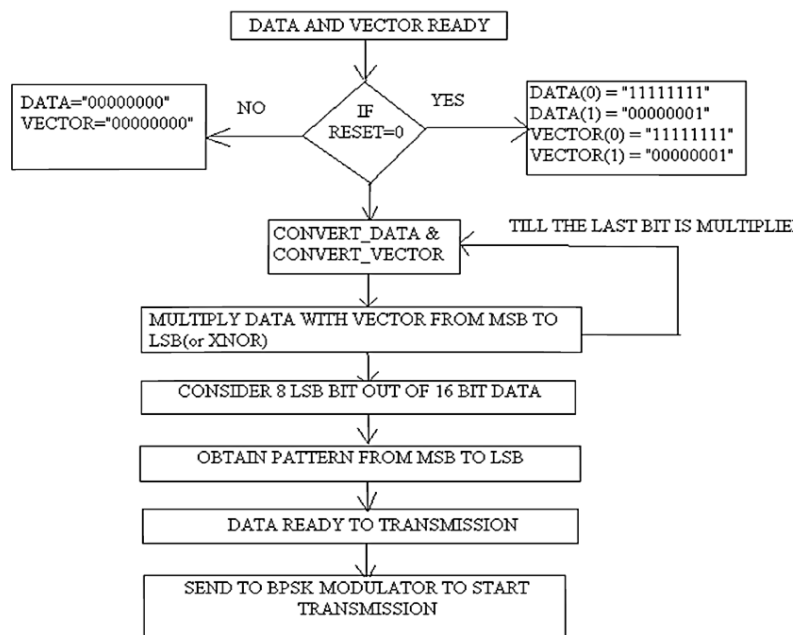

Fig. 5. Flow chart of the DS-CDMA Encoding

International Journal of Innovative Research in Science, Engineering and Technology

(A High Impact Factor, Monthly, Peer Reviewed Journal)

Visit: www.ijirset.com

Vol. 7, Issue 6, June 2018

In DS-SS receiver, the BPSK modulated signal is the input to the system. This signal would have been affected by noise and other interference in the communication channel. The DS-SS receiver should be designed carefully to reproduce the data signal with least error.

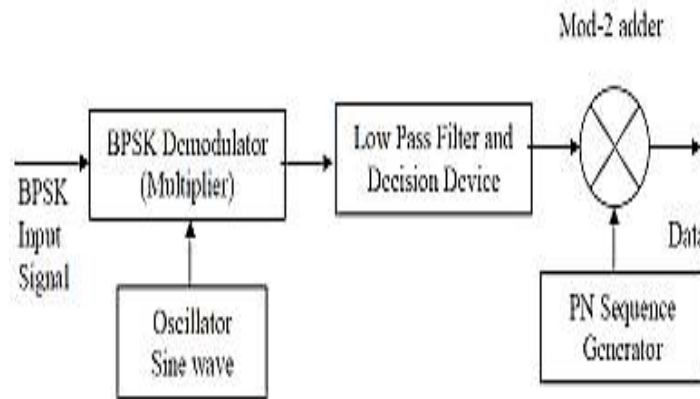

Fig. 6. Block diagram of a DS-SS receiver system

The oscillator multiplies the locally generated carrier wave to the BPSK modulated input signal. To get low frequency components, the multiplied signal is passed through the low pass filter. To approximate the signal to binary sequence, a decision device is used. This binary sequence is the spread sequence of the data signal.

The synchronization of the sequence obtained from the decision device and the locally generated PN sequence is the most sensitive part of the DS-SS receiver. Noise is produced instead of the data signal, when a single bit mismatch occurs. To achieve synchronization and to multiply the locally generated PN sequence code with that of the received PN code, suitable technique is used. After the multiplication process, the Data signal is obtained.

In this design, the delay in the receiver is considered and modelled appropriately, as the transmitter and receiver uses common clock on the same FPGA board.

The block diagram of a simple DS-SS receiver system is shown in Fig-6.

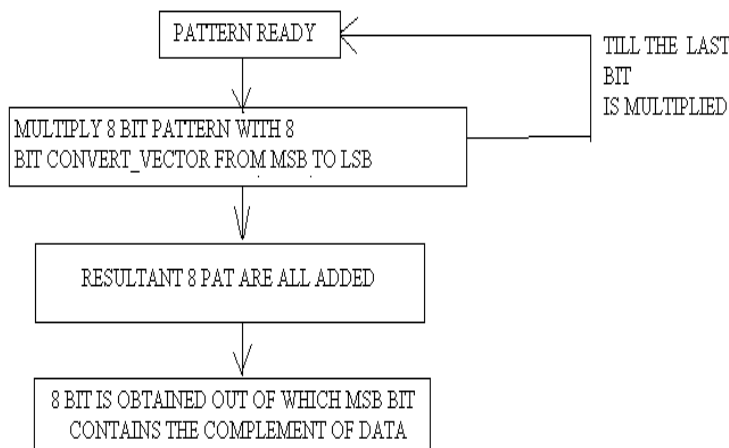

Fig. 7. Flow chart of the DS-CDMA decoding

International Journal of Innovative Research in Science, Engineering and Technology

(A High Impact Factor, Monthly, Peer Reviewed Journal)

Visit: www.ijirset.com

Vol. 7, Issue 6, June 2018

VI. EXPERIMENTAL RESULTS

The proposed DS_CDMA is implemented using VHDL, the functionality of the algorithm is verified using Mentor Graphics and synthesized using Xilinx ISE.

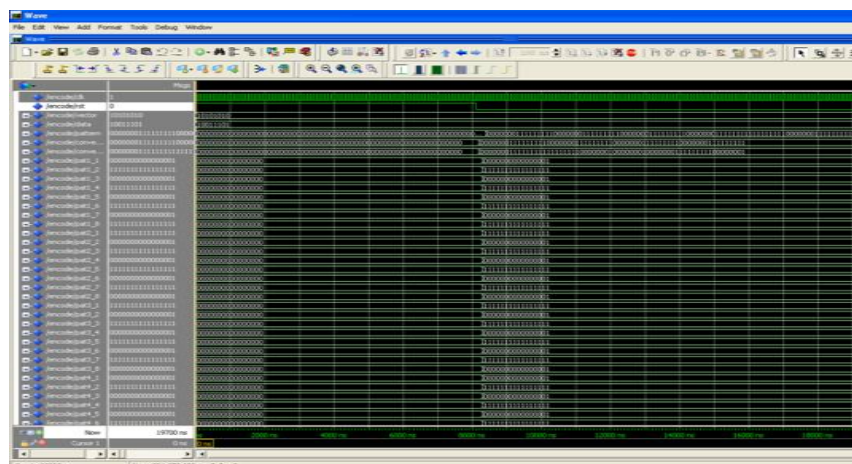

Fig. 8. Output of encoding process

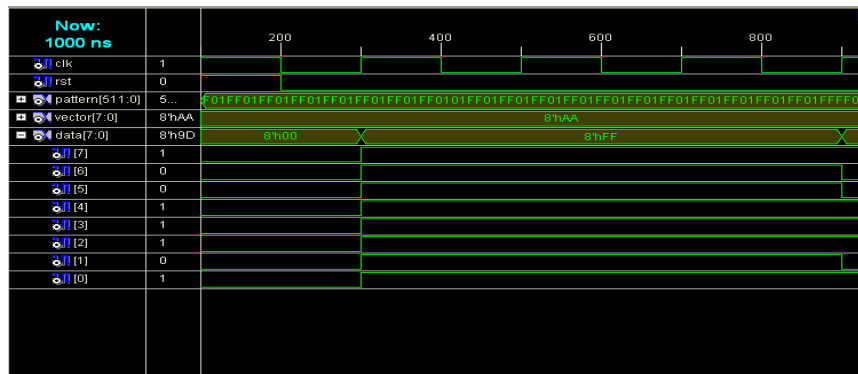

Fig. 9. Output of decoding process

REFERENCES

- [1] Chang. K. C.(1997),Digital Design and Modeling with VHDL and Synthesis, IEEE servicecenter, Piscataway.
- [2] Sreedevi, B., Vijaya, V., Rekh, C. K., Valupadasu, R., & Chunduri, B. R. (2011, March). FPGA implementation of DSSS-CDMA transmitter and receiver for ADHOC networks. In Computers & Informatics (ISCI), 2011 IEEE Symposium on (pp. 255-260). IEEE.
- [3] Milstein, Laurence B. "Wideband code division multiple access." IEEE Journal on Selected areas in Communications 18.8 (2000): 1344-1354.
- [4] Litvinenko, Anna, and Arturs Aboltins. "Selection and performance analysis of chaotic spreading sequences for DS-CDMA systems." Advances in Wireless and Optical Communications (RTUWO), 2016. IEEE, 2016.
- [5] Moshavi, Shimon. "Multi-user detection for DS-CDMA communications." IEEE communications magazine 34.10 (1996): 124-136.
- [6] Cheah,J.,Y.C.,Practical Wireless Data Modem Design, Artech House Publishers, Boston, London,1999.
- [7] Feher,K.(1995),Wireless Digital Communications, PrenticeHall,Inc., Upper Saddle River, New Jersey.
- [8] Gil,H.,K., PN Code Acquisition Using Non parametric Detection DS- CDMA Systems, Department of Electrical and Electronic, Korea Advanced Institute of Science and Technology (KAIST), South Korea,2000.
- [9] Halsall,F., Data Communications, Computer Networks and Open Systems, Addison- Wesley Publications company, Harlow, England,1996.



ISSN(Online): 2319-8753
ISSN (Print): 2347-6710

International Journal of Innovative Research in Science, Engineering and Technology

(A High Impact Factor, Monthly, Peer Reviewed Journal)

Visit: www.ijirset.com

Vol. 7, Issue 6, June 2018

- [10] Jakes, W.C., Jr. (1994), Microwave Mobile Communications, J. Wiley & Sons, New York, 1974; IEEE Press, 1994, ISBN0-7803-1069-
- [11] Oianpera, T., Prasad, R., Wideband CDMA for Third Generation Mobile Communications, Artech House Publishers, Boston, London, 1998.
- [12] Rushton, A., VHDL for Logic Synthesis, John Wiley & Sons Ltd, Chichester, England, 1998.
- [13] Anupama Shetter, "High Speed DAS using Aurora Protocol with Error Detection" at International Journal of Engineering Science and Computing, Volume 6 Issue No. 6, ISSN 2321 3361 © 2016.